

# Motorschutzbügel



**HONDA CB 500 X**  
501.978 00 05 anthrazit

**HONDA CB 500 F**  
ab 2013  
501.977 00 05 anthrazit

**KRAUSER**  
MOTORRADGEPÄCKSYSTEME ■ BIKE BAGS

**HONDA CB 500 X**  
3001.062.101 anthrazit

**HONDA CB 500 F**  
ab 2013  
3001.061.101 anthrazit

## Montage

Der Bausatz umfasst die folgenden Teile:

Stück	Bestellnr.	Bezeichnung			
1	700008001	Motorschutzbügel links	1	151.232	Inbusschraube M10 x 180mm
1	700008002	Motorschutzbügel rechts	4	150.811	U – Scheibe Ø 10,5
1	150.856	Sechskantschraube M10 x 55 x 1,25	1	150.801	selbstsichernde Mutter M 10
1	151.201	Sechskantschraube M10 x 70 x 1,25	1	151.395	Stahldistanz Ø22 x Ø14 x 10mm



**Anzugsmomente des Motorradherstellers beachten!**  
Nach der Montage alle Verschraubungen auf festen Sitz kontrollieren!  
Bitte beachten Sie unsere beigefügten Serviceinformationen.

Als weiteres Zubehör lieferbar:  
Kofferträger (Lock it System, abnehmbar)  
Gepäckbrücke  
Tankschutzbügel  
Hauptständer  
C-Bow Halter für Softtaschen  
Frontschutzbügel für Fahrschulen  
Heckschutzbügel für Fahrschulen



**Hepco & Becker GmbH**  
An der Steinmauer 6  
D-66955 Pirmasens  
Tel.: 0049 6331 - 1453 - 100  
[www.hepco-becker.de](http://www.hepco-becker.de)



**Krauser GmbH**  
An der Steinmauer 6  
D-66955 Pirmasens  
Tel.: 0049 6331 - 1453 - 250  
[www.krauser.de](http://www.krauser.de)

# Motorschutzbügel



**HONDA CB 500 X**  
501.978 00 05 anthrazit

**HONDA CB 500 F**  
ab 2013  
501.977 00 05 anthrazit

**KRAUSER**  
MOTORRADGEPÄCKSYSTEME ■ BIKE BAGS

**HONDA CB 500 X**  
3001.062.101 anthrazit

**HONDA CB 500 F**  
ab 2013  
3001.061.101 anthrazit

## Montage

### Vorbereitende Arbeiten:

Fußrastenhalterung rechts und links demontieren. Achtung: in Fahrtrichtung rechts den Bremszylinder nicht von der Fußrastenanlage trennen!  
Spritzschutz des vorderen Ritzels lösen, um die Schraube der Motoraufhängung hinten, unten besser zu erreichen.

### Befestigung des Motorschutzbügels hinten unten links und rechts:

Die Befestigung hinten unten links erfolgt mit der Inbusschraube M10 x 180mm (Originalschraube entfällt) mit der U-Scheibe Ø10,5.

An diese Schraube wird auch der Motorschutzbügel auf der rechten Seite mit der U-Scheibe Ø10,5 und selbstsichernder Mutter M10 befestigt.

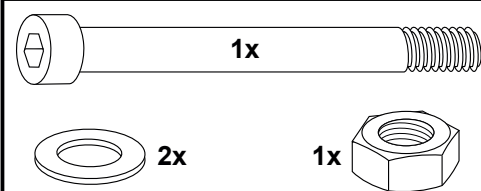

**1**

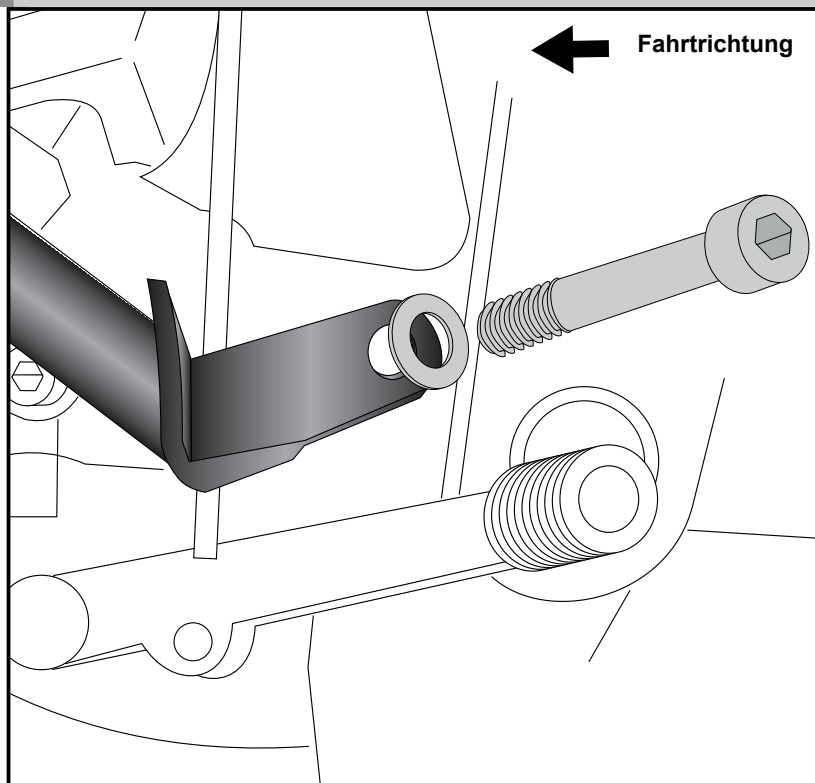

### Befestigung Motorschutzbügel vorne links:

Die Originalschraube entfällt.  
Die Befestigung erfolgt mit der Sechskantschraube M10 x 70 x 1,25 und U-Scheibe Ø 10,5.

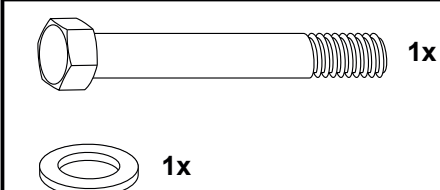

**2**

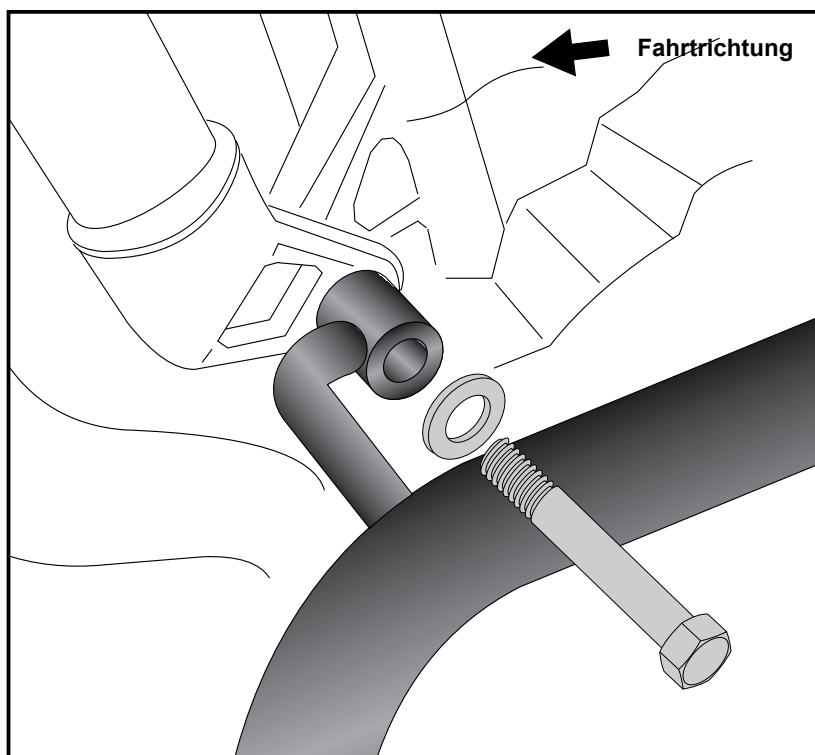

# Motorschutzbügel



**HONDA CB 500 X**  
501.978 00 05 anthrazit

**HONDA CB 500 F**  
ab 2013  
501.977 00 05 anthrazit

**KRAUSER**  
MOTORRADGEPÄCKSYSTEME ■ BIKE BAGS

**HONDA CB 500 X**  
3001.062.101 anthrazit

**HONDA CB 500 F**  
ab 2013  
3001.061.101 anthrazit

## Montage

Befestigung Motorschutzbügel vorne rechts: **3**

Die Originalschraube entfällt.  
Zwischen Motorschutzbügel und Rahmen  
die Distanz  $\varnothing 22 \times \varnothing 14 \times 10\text{mm}$  fügen.  
Die Befestigung erfolgt mit der  
Sechskantschraube M10 x 70 x 1,25 und  
U – Scheibe  $\varnothing 10,5$ .  
Abschließend alle Verschraubungen  
festziehen und demontierte Anbauteile  
wieder montieren.

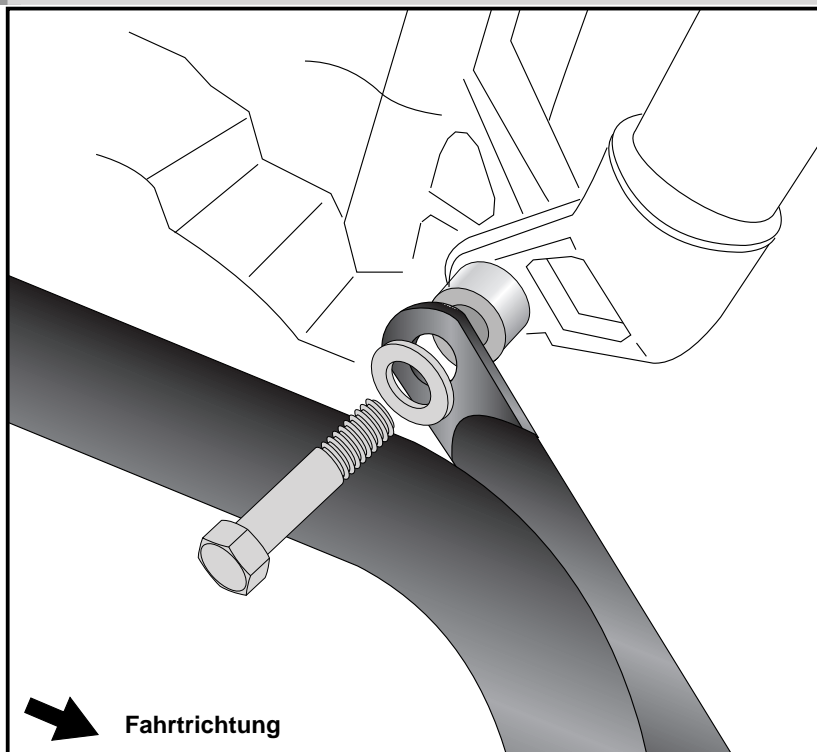
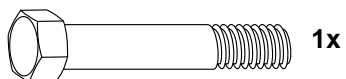

# Engine guard



**HONDA CB 500 X**  
501.978 00 05 anthracite

**KRAUSER**  
MOTORRADGEPÄCKSYSTEME ■ BIKE BAGS

**HONDA CB 500 X**  
3001.062.101 anthracite

**HONDA CB 500 F**  
from 2013  
3001.061.101 anthracite

## Assembling instructions

The kit includes the following parts:

Quant	item no.	description			
1	700008001	engine guard left	1	151.232	allen screw M10 x 180mm
1	700008002	engine guard right	4	150.811	washer Ø 10,5
1	150.856	hexagon bolt M10 x 55 x 1,25	1	150.801	self lock nut M 10
1	151.201	hexagon bolt M10 x 70 x 1,25	1	151.395	steel spacer Ø22 x Ø14 x 10mm



**Control all screw connections after the assembling for tightness!**  
**Please notice our enclosed service information.**

Also available:  
Side carrier (Lock it System, removable)  
Rear rack  
Tank guard  
Center stand  
C-Bow Holder for softbags  
Front guard for driving schools  
Rear guard for driving schools



**Hepco & Becker GmbH**  
An der Steinmauer 6  
D-66955 Pirmasens  
Tel.: 0049 6331 - 1453 - 100  
[www.hepco-becker.de](http://www.hepco-becker.de)



**Krauser GmbH**  
An der Steinmauer 6  
D-66955 Pirmasens  
Tel.: 0049 6331 - 1453 - 250  
[www.krauser.de](http://www.krauser.de)

# Engine guard



**HONDA CB 500 X**  
501.978 00 05 anthracite

**HONDA CB 500 F**  
from 2013  
501.977 00 05 anthracite

**KRAUSER**  
MOTORRADGEPÄCKSYSTEME ■ BIKE BAGS

**HONDA CB 500 X**  
3001.062.101 anthracite

**HONDA CB 500 F**  
from 2013  
3001.061.101 anthracite

## Assembling instructions

**Preparing:**  
dismantle footrest holder right and left.  
**NOTICE:** Do not disconnect the brake cylinder from the footrest!  
Dismantle splash guard of the front pinion to reach the bolt of the rear engine mount, bottom better.

### Fastening of the engine guard

#### left and right rear bottom:

For the rear left bolting use the allen screw M10 x 180mm (original screw is obsolete) with washer  $\varnothing 10,5$ .

Fix the engine guard right at these screw and secure it with washer  $\varnothing 10,5$  and self lock nut M10.

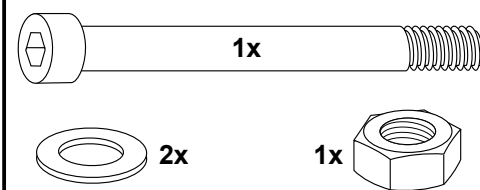

**1**

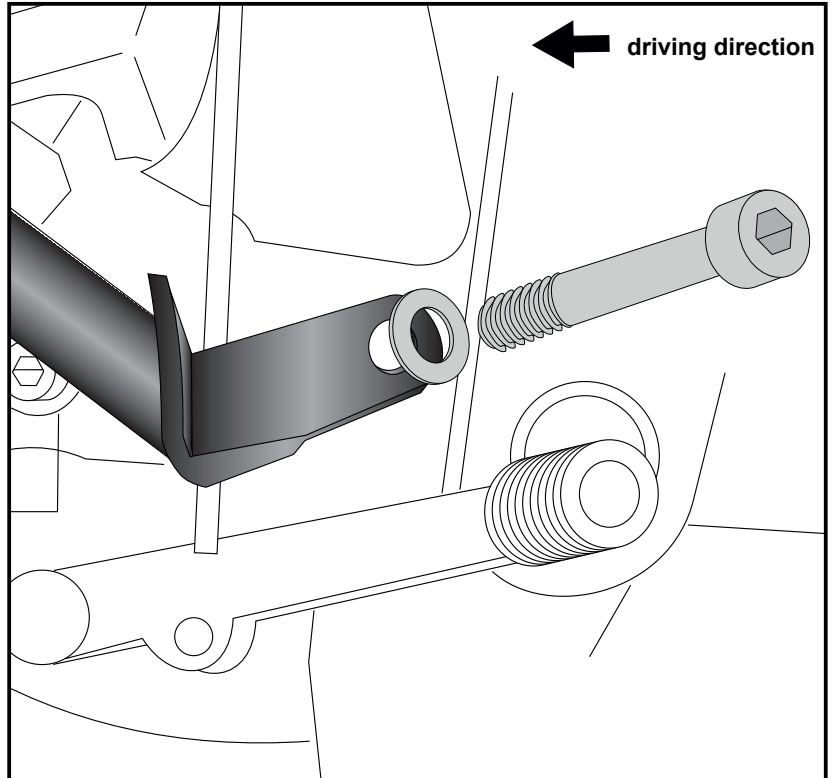

**Fastening of the engine guard left front:**  
For the bolting use the hexagon screw M10 x 70 x 1,25 with washer  $\varnothing 10,5$ .  
Original screw is obsolete.

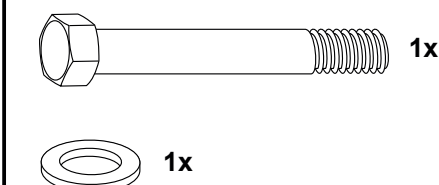

**2**

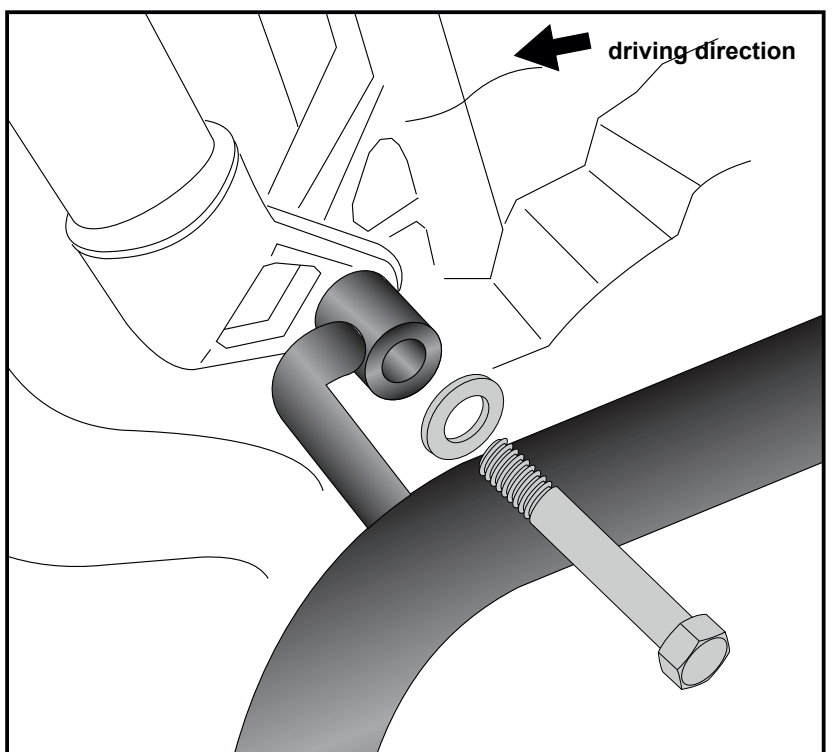

# Engine guard



**HONDA CB 500 X**  
501.978 00 05 anthracite

**HONDA CB 500 F**  
from 2013  
501.977 00 05 anthracite

**KRAUSER**<sup>®</sup>

MOTORRADGEPÄCKSYSTEME ■ BIKE BAGS

**HONDA CB 500 X**  
3001.062.101 anthracite

**HONDA CB 500 F**  
from 2013  
3001.061.101 anthracite

## Assembling instructions

Fastening of the engine guard right front: **3**

For the bolting use the hexagon screw M10 x 70 x 1,25 with washer Ø10,5. Sandwich spacer Ø22 x Ø14 x 10mm between engine guard and frame. Original screw is obsolete.

Finally, tighten all screws and reassemble dismantled attachments.

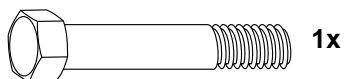

1x



1x



1x

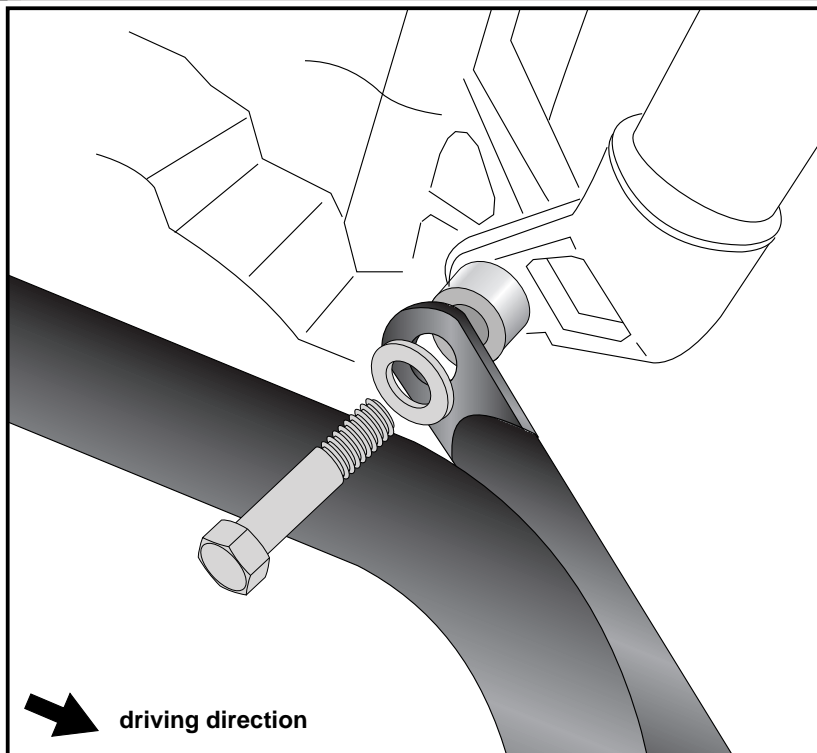

driving direction