

Motorschutzbügel
HONDA CB 600 F Hornet
ab Bj. 07

Art.-Nr.: 501.948 00 01 schwarz
Art.-Nr.: 501.965 00 01 schwarz

Seitenkoffer
Topcases
Gepäckträger
Lock it System
Softbags
Aluminiumkoffer
Lederkoffer
Schutzbügel
Hauptständer
Chopper-Parts
Quad-Parts
Accessoires



Montage

St.	Bestellnr.	Bezeichnung
1	701.507	Motorschutzbügel links
1	701.508	Motorschutzbügel rechts
1	151.096	Silentblock M8 5218027
2	150.895	Hutmutter M8
1	151.097	Inbusschraube M12 x 200
1	151.033	Selbstsichernde Mutter M12
2	150.976	U-Scheibe Ø12,5
2	150.810	U-Scheibe Ø 8,4
1	151.032	Distanz (für rechte Seite) Ø25 x Ø12,5 x 15
1	151.098	Distanz (für linke Seite) Ø25 x Ø13 x 24

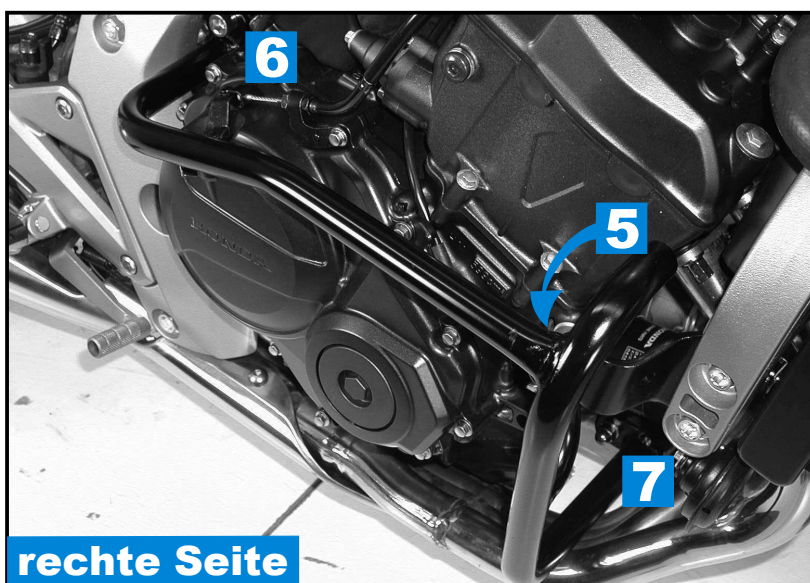
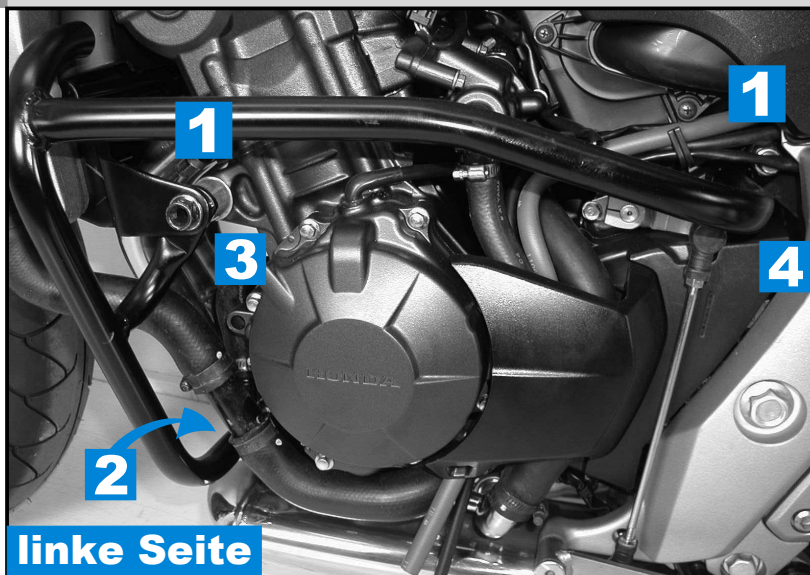

Motorschutzbügel
HONDA CB 600 F Hornet
ab Bj. 07

Art.-Nr.: 501.948 00 01 schwarz
Art.-Nr.: 501.965 00 01 schwarz

Seitenkoffer
Topcases
Gepäckträger
Lock it System
Softbags
Aluminiumkoffer
Lederkoffer
Schutzbügel
Hauptständer
Chopper-Parts
Quad-Parts
Accessoires



Montage

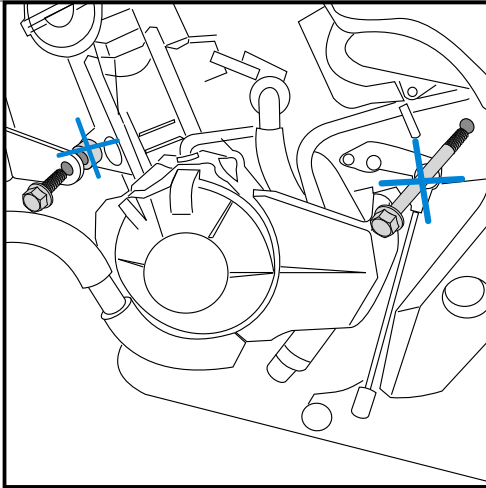

1 linke Seite

Allgemeine Vorbereitung:
Beginnen Sie auf der linken Seite !
Demontieren sie die Motorbefestigungsschrauben vorne und hinten.
Die Orginalschrauben vorne werden wieder verwendet.
Die Distanzen vorne und die Orginalschrauben hinten entfallen.

Achtung: Seite für Seite anbauen!
Andernfalls kann der Motor sich absenken!

Tipp:
Schrauben sie alle Teile an und lassen sie die zugänglichen Schrauben etwas locker. Nachdem alles montiert ist, werden alle Schrauben auf das entsprechende Anzugsmoment angezogen. Dadurch wird sichergestellt, dass das Produkt spannungsfrei angebaut ist. So ist eine lange Lebensdauer gewährleistet !

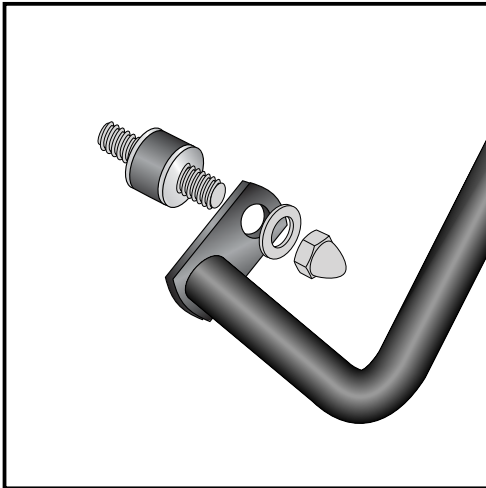

2

Vorbereitung des Motorschutzbügels:
Schrauben Sie den Silentblock an den Bügel mit U-Scheibe Ø8,4 und Hutmutter M8.

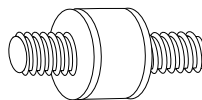

je 1x

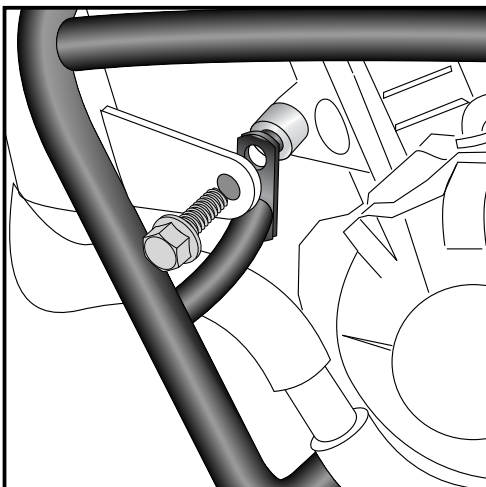
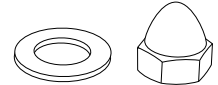

3

Montage vorne oben:
Hinter die Kühlerbefestigung über den freien Bohrungen platzieren, dahinter die Distanz ø25 x ø 13 x 24 einschieben und mit der Original-Schraube befestigen.



1x

Motorschutzbügel
HONDA CB 600 F Hornet
ab Bj. 07

Art.-Nr.: 501.948 00 01 schwarz
Art.-Nr.: 501.965 00 01 schwarz



Seitenkoffer
Topcases
Gepäckträger
Lock it System
Softbags
Aluminiumkoffer
Lederkoffer
Schutzbügel
Hauptständer
Chopper-Parts
Quad-Parts
Accessoires

Montage

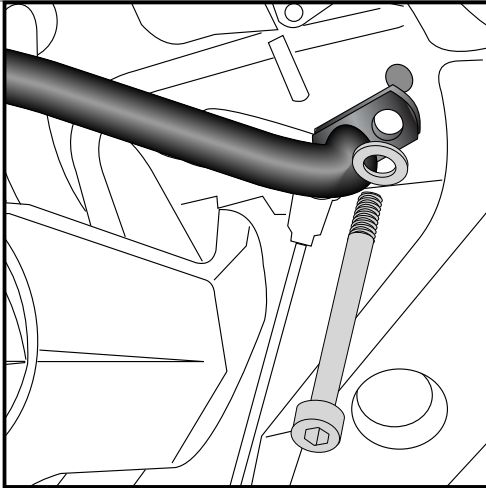

4

Montage hinten oben:
Inbusschraube M12 x 200 inkl. U-Scheibe $\varnothing 12,5$ einschieben.
Diese wird erst im nächsten Montage-Schritt festgezogen.

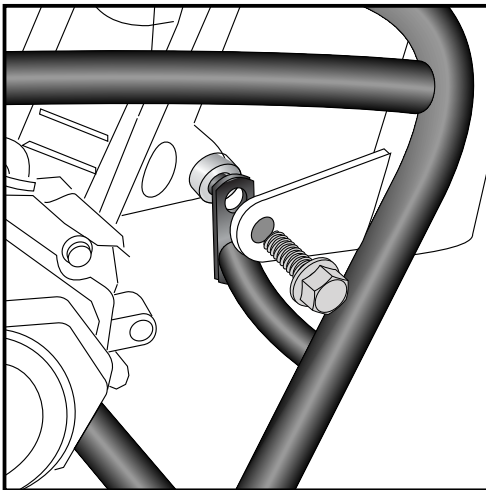
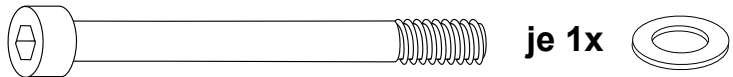

5

rechte Seite

Vorbereitung:
Demontieren sie die Motorbefestigungsschrauben vorne.
Die Originalschrauben vorne werden wieder verwendet.
Die Distanz entfällt.

Montage vorne oben:
Hinter die Kühlerbefestigung über den freien Bohrungen platzieren, dahinter
die Distanz $\varnothing 25 \times \varnothing 12,5 \times 15$ einschieben und mit der Original-Schraube
befestigen.

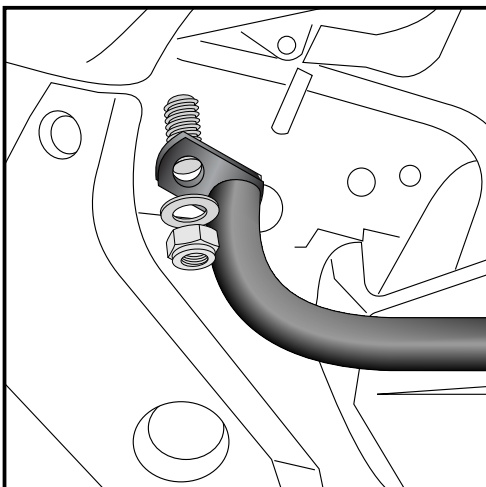
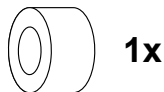

6

Montage hinten oben:
Den Bügel entsprechend positionieren.
Der Bügel wird auf das überstehende Ende der Inbusschraube M12 x 200
geschoben, mit der U $\varnothing 12,5$ und selbstsichernde Mutter M12 befestigt.

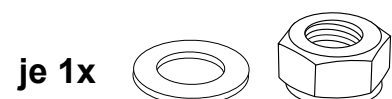

Motorschutzbügel
HONDA CB 600 F Hornet
ab Bj. 07

Art.-Nr.: 501.948 00 01 schwarz
Art.-Nr.: 501.965 00 01 schwarz

Seitenkoffer
Topcases
Gepäckträger
Lock it System
Softbags
Aluminiumkoffer
Lederkoffer
Schutzbügel
Hauptständer
Chopper-Parts
Quad-Parts
Accessoires



Montage

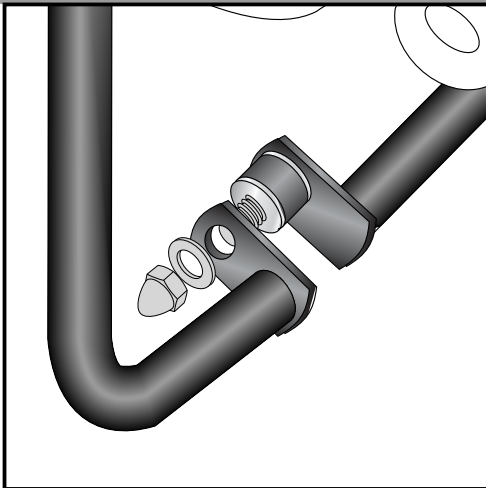

7

Verbindung beider Bügel, vorne unten:
Die rechte Bügelhälfte wird auf den bereits am linken Bügel befestigten
Silentblock geschoben und mit Hutmutter und U-Scheibe Ø8,4 verschraubt.

je 1x

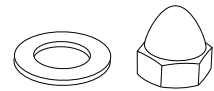

Anzugsmomente des Motorradherstellers beachten!

Nach der Montage alle Verschraubungen auf festen Sitz kontrollieren!

Bitte beachten Sie unsere beigefügten Serviceinformationen.

Als weiteres Zubehör lieferbar:

650.948 00 01 Kofferträger schwarz "Lock it System" (abnehmbar)
650.948 01 01 Gepäckbrücke schwarz



Hepco & Becker GmbH
An der Steinmauer 6

D-66955 Pirmasens

Tel.: 06331 - 1453 - 100

Fax: 06331 - 1453 - 120

eMail: vertrieb@hepco-becker.de

www.hepco-becker.de

Engine guard
Hornet CB 600 F Hornet
from year of manufacture 2007

Item-No.
501.948 00 01 black
501.965 00 01 black

- Side cases
- Top cases
- luggage frames
- Lock it system
- Softbags
- Aluminium luggage
- Leather luggage
- Protection bars
- Center stands
- Chopper parts
- Quad parts
- Accessories



Assembling instructions

St.	Bestellnr.	Bezeichnung
1	701.507	engine guard left
1	701.508	engine guard right
1	151.096	silent block M8 No.5218027
2	150.895	cap nut M8
1	151.097	allen screw M12 x 200
1	151.033	self-lock nut M12
2	150.976	washer Ø12,5
2	150.810	washer Ø 8,4
1	151.032	spacer (right side) Ø25 x Ø12,5 x 15
1	151.098	spacer (left side) Ø25 x Ø13 x 24

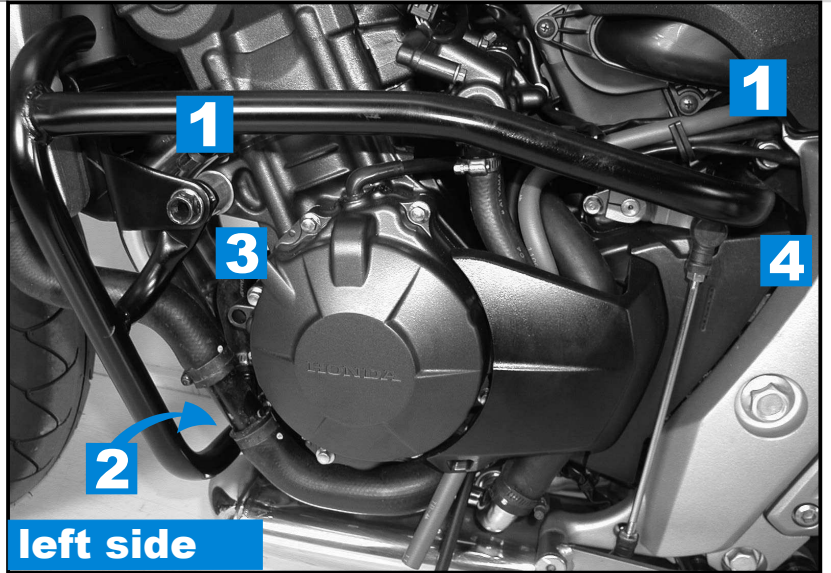

left side

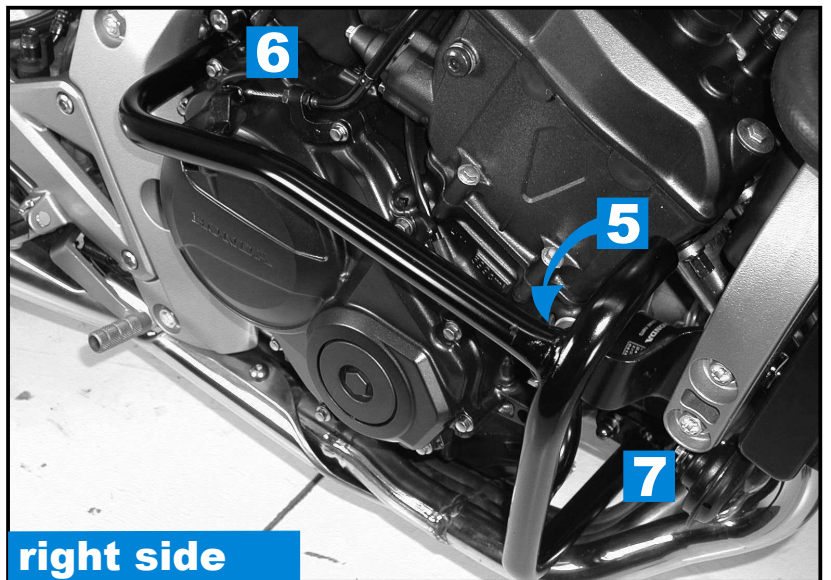

right side

Engine guard
Hornet CB 600 F Hornet
from year of manufacture 2007

Item-No.
501.948 00 01 black
501.965 00 01 black

Side cases
Top cases
luggage frames
Lock it system
Softbags
Aluminium luggage
Leather luggage
Protection bars
Center stands
Chopper parts
Quad parts
Accessories



Assembling instructions

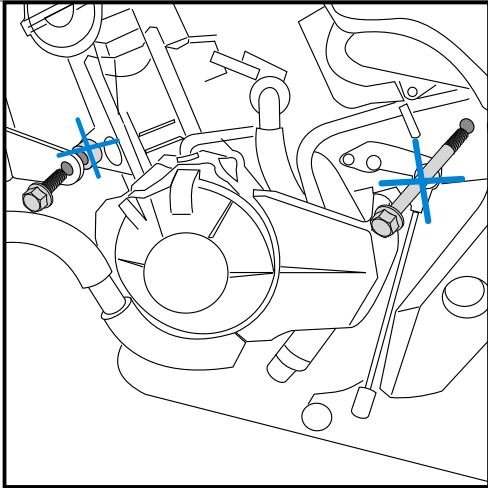

1 left side

Preparing:
Start with the left side !
Unmount original engine screws front and back.
The original spacers front and the screws back are not needed any more.

Notice: Do it side by side!

Tip:

**Fit all parts and screw on not too strong.
After mounting all parts, the screws should be tightened
to the torque specified.
This guarantees, that the kit is mounted without tension.**

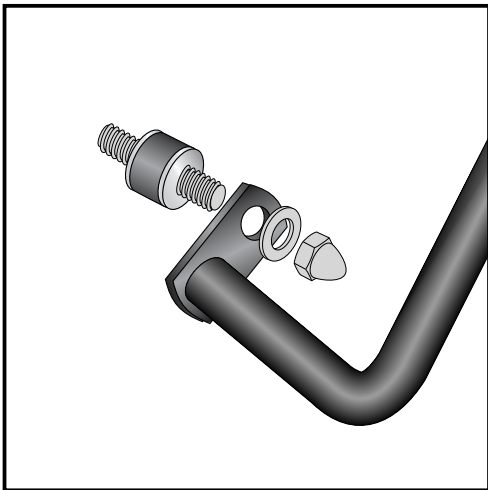

2

Preparing:
Screw silent block to the left engine guard with washer $\varnothing 8,4$
and cup nut M8.

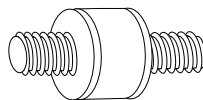

each 1x

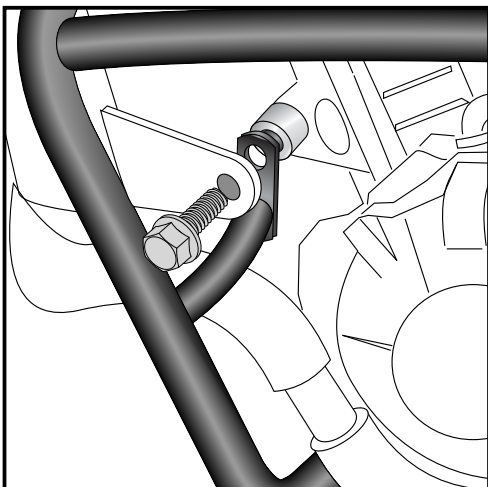
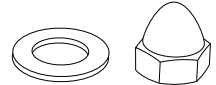

3

Fastening of crash bar front top:
behind the cooler fixing in the thread with original screw.
Sandwich spacer $\varnothing 25 \times \varnothing 13 \times 24$.

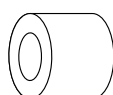

1x

Luggage ideas.

Engine guard
Hornet CB 600 F Hornet
from year of manufacture 2007

Item-No.
501.948 00 01 black
501.965 00 01 black

Side cases
Top cases
luggage frames
Lock it system
Softbags
Aluminium luggage
Leather luggage
Protection bars
Center stands
Chopper parts
Quad parts
Accessories



Assembling instructions

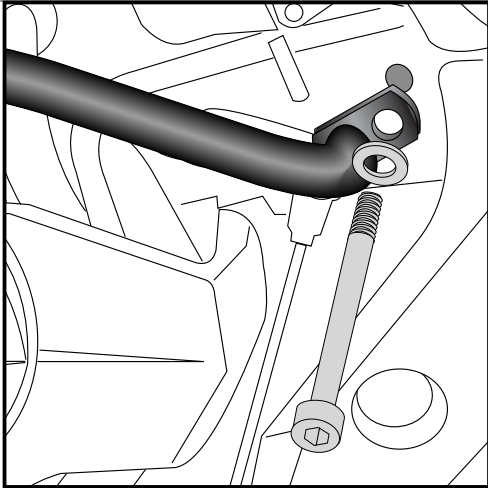

4

Fastening of crash bar front back:
Pull through allen screw M12 x 200 with washer \varnothing 12,5.

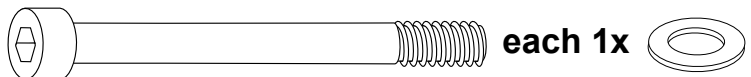

each 1x

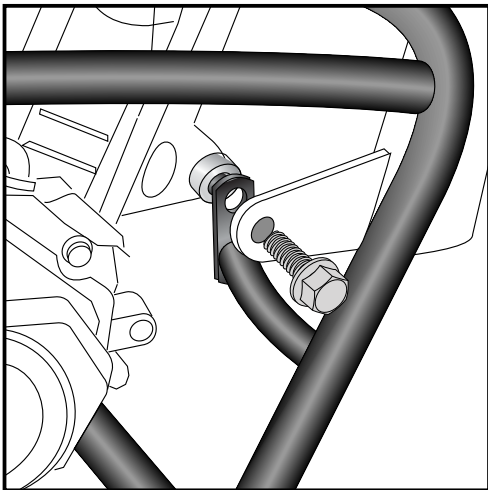

5

right side

Preparing:
Unmount original engine screws front.
The original spacers front is not needed any more.

Fastening of crash bar front top:
behind the cooler fixing in the thread with original screw.
Sandwich spacer \varnothing 25 x \varnothing 12,5 x 15.

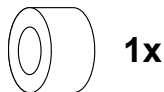

1x

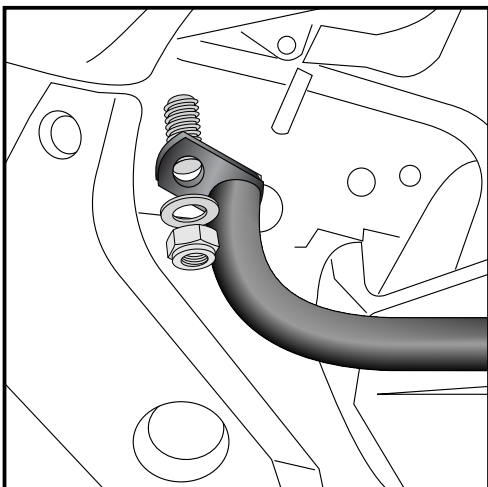

6

Fastening of crash bar back top:
Fix the engine guard at the thread of the allen screw M12 x 200
(mounted in step 4) with washer \varnothing 12,5 and self-lock nut M12.

each 1x

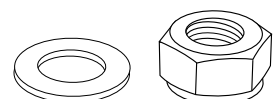

Luggage ideas.

Engine guard
Hornet CB 600 F Hornet
from year of manufacture 2007

Item-No.
501.948 00 01 black
501.965 00 01 black

Side cases
Top cases
luggage frames
Lock it system
Softbags
Aluminium luggage
Leather luggage
Protection bars
Center stands
Chopper parts
Quad parts
Accessories



Assembling instructions

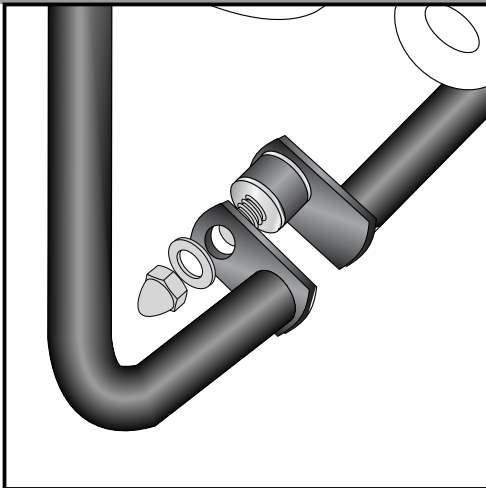

7

Connection of the bars:

The right side of the crash bar will be fixed to the silent block at the left bar.
Use cap nut with washer Ø8,4.

each 1x

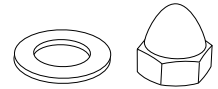

Control all screw connections after the assembling for tightness!

Please notice our enclosed service information.

All screws, bolts and nuts should be checked after driving the first 50 km to ensure that all are tightened to the proper torque.

Medium strength liquid thread-locker (i.e., „Loctite“) should be used to secure all screws, bolts, and nuts.

Also available:

Side carrier 650.948 00 01 black, „Lock it System“ (removable)

Rear rack 650.948 01 01 black



Hepco & Becker GmbH
An der Steinmauer 6
D-66955 Pirmasens
Germany

Tel.: +49 6331 - 1453 - 100

Fax: +49 6331 - 1453 - 120

eMail: vertrieb@hepco-becker.de

www.hepco-becker.de