

Motorschutzbügel

HONDA Crossrunner

Art.-Nr.:

501.968 00 01 schwarz

Seitenkoffer

Topcases

Gep cktr ger

Lock it System

Softbags

Aluminiumkoffer

Lederkoffer

Schutzbügel

Hauptständer

Chopper-Parts

Quad-Parts

Accessoires



Montage

Der Bausatz umfasst die folgenden Teile:

Stück Bestellnr.	Bezeichnung	Stück Bestellnr.	Bezeichnung
1 700007601	Motorschutzbügel links	2 150.782	Inbusschrauben M8x20
1 700007602	Motorschutzbügel rechts	4 150.811	U-Scheiben Ø10,4
1 700007600	Halteadapter	4 150.810	U-Scheiben Ø8,4
1 151.155	Inbusschraube M10x85x1,25	1 150.801	selbstsichernde Mutter M10
1 150.952	Inbusschraube M10x60x1,25	2 150.800	selbstsichernde Muttern M8
1 150.869	Inbusschraube M10x50	2 151.089	Aludistanzen Ø20xØ11x13mm



Anzugsmomente des Motorradherstellers beachten!

Nach der Montage alle Verschraubungen auf festen Sitz kontrollieren!

Bitte beachten Sie unsere beigefügten Serviceinformationen.

Als weiteres Zubehör lieferbar:

Kofferträger (Lock it System, abnehmbar)

Gepäckbrücke

Hauptständer

C-Bow Halter für Softtaschen

Art.-Nr.: 650.968 00 01

Art.-Nr.: 650.968 01 01

Art.-Nr.: 505.968

Art.-Nr.: 630.968



Hepco & Becker GmbH
An der Steinmauer 6

D-66955 Pirmasens

Tel.: 06331 - 1453 - 100

Fax: 06331 - 1453 - 120

eMail: vertrieb@hepco-becker.de

www.hepco-becker.de

Motorschutzbügel

HONDA Crossrunner

Art.-Nr.:

501.968 00 01 schwarz

Seitenkoffer

Topcases

Gep ckt ger

Lock it System

Softbags

Aluminiumkoffer

Lederkoffer

Schutzbügel

Hauptständer

Chopper-Parts

Quad-Parts

Accessoires



Montage

Befestigung des vorderen Halteadapters:

Dieser wird an der Cockpithalterung unterhalb des Scheinwerfers und oberhalb der Hupe montiert. Originalschraube entfällt.

Den Halteadapter über die Cockpithalterung schieben und mit der Inbuschraube M10x50, selbstsichernder Mutter M10 und U-Scheiben Ø10,4 verschrauben.

Adapter ganz nach oben drücken und festziehen.

Hinweis: Kotflügel zum Schutz abdecken

1

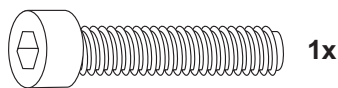
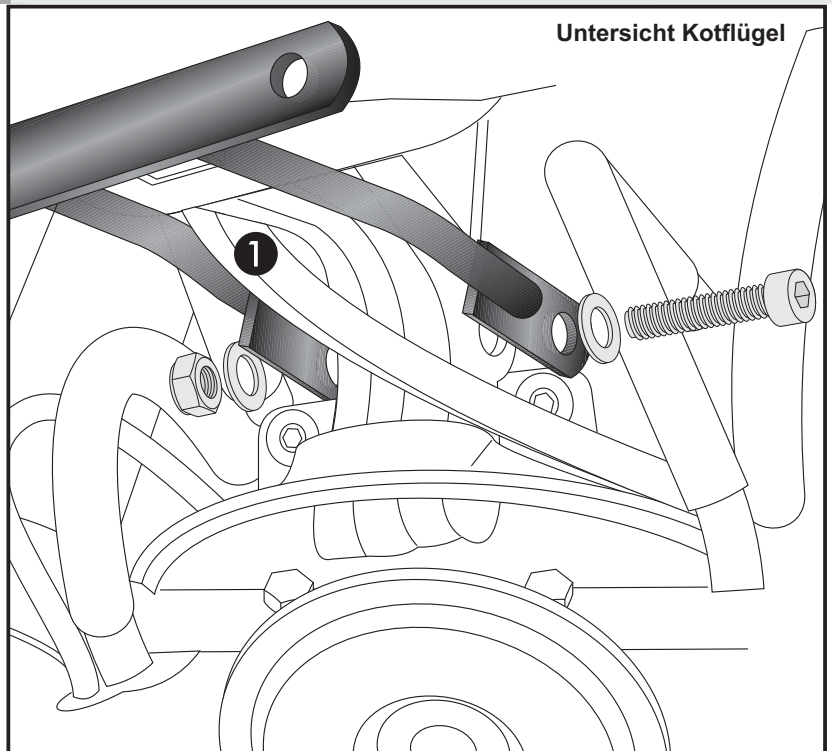

2x

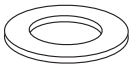

1x



Achtung:

Die beiden Stromkabel (1) müssen zwischen den Laschen des Adapters verlaufen.

Montagetip aufgrund der beengten Verhältnisse:

in Fahrtrichtung gesehen den Ring-schlüssel von oben am Lenker rechts einführen und die Mutter anhalten. Von unten mit einer kleinen Ratsche und Inbusnuss Größe 8 die Schraube anziehen. Nach der Montage den Lenker ganz nach links und rechts bewegen. Hierbei kontrollieren, dass keine Leitung geklemmt wird.

2

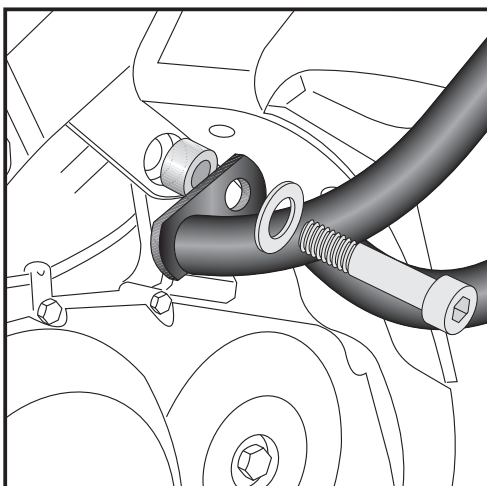

Montage der Motorschutzbügel links und rechts:

Diese werden an der mittleren Motoraufhängung befestigt. Die Originalschrauben demontieren - sie entfallen. In die Rahmenöffnung die Aludistanz Ø20xØ11x13 mm stecken. Die Bügel mit den Inbuschrauben M10x85 links und M10x60 rechts sowie U-Scheiben Ø10,4 montieren.

Schrauben nur locker eindrehen - erst nach Montage des vorderen Befestigungspunktes die Schrauben endgültig anziehen.

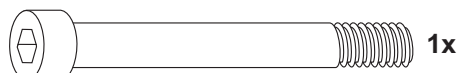

2x

2x

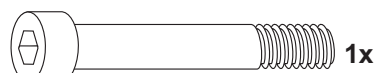

Packende Ideen.

2

Motorschutzbügel

HONDA Crossrunner

Art.-Nr.:

501.968 00 01 schwarz

Seitenkoffer

Topcases

Gep cktr ger

Lock it System

Softbags

Aluminiumkoffer

Lederkoffer

Schutzbügel

Hauptständer

Chopper-Parts

Quad-Parts

Accessoires



Montage

Montage der Motorschutzbügel vorne:
Die beiden Motorschutzbügel über dem abgedeckten Kotflügel zusammenschieben und nach oben drehen zur Verschraubung mit dem Adapter.

3

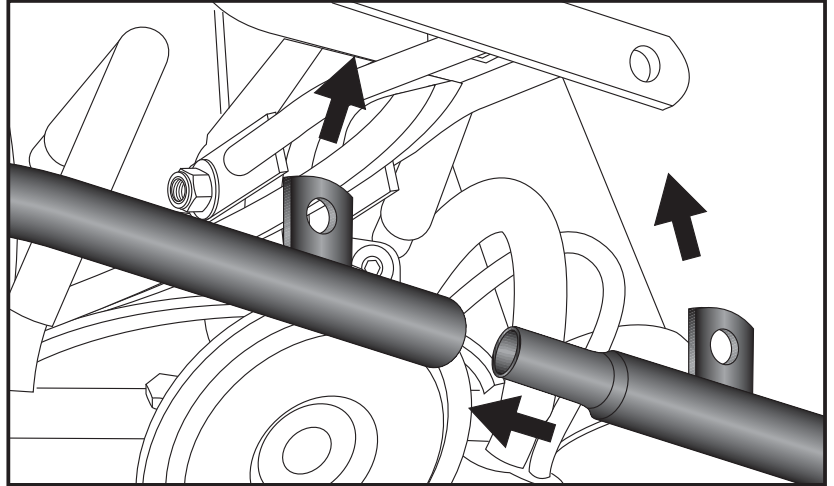

Montage der Motorschutzbügel vorne:
an dem zuvor montierten Adapter mit den Inbusschrauben M8x20 sowie U-Scheiben Ø8,4 und selbstsichernden Muttern M8 verschrauben.

Nun alle Teile nochmals fest anziehen.

3

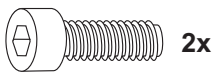
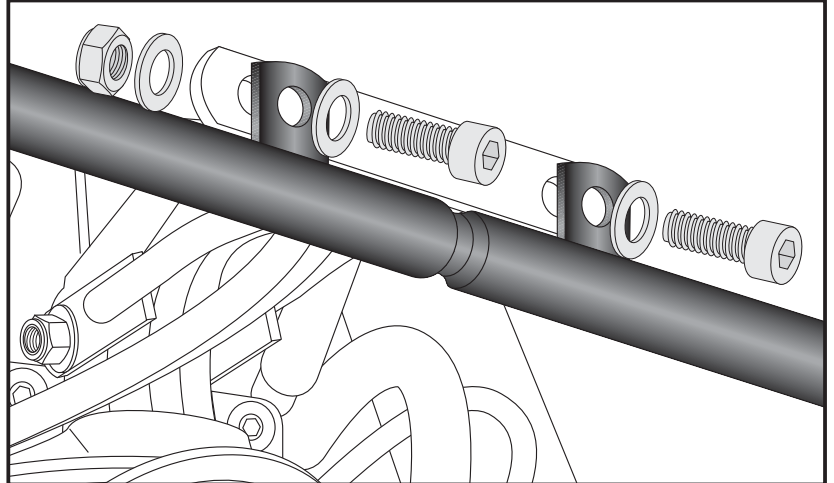

2x

4x



2x



Engine guard

HONDA Crossrunner

Item - No.:
501.968 00 01 black

Side cases
Top cases
Luggage frames
Lock it system
Softbags
Aluminium luggage
Leather luggage
Protection bars
Center stands
Chopper parts
Accessories



Assembling instructions

The kit includes the following parts:

Quant	item no.	description	Quant	item no.	description
1	700007601	engine guard left	2	150.782	allen screw M8x20
1	700007602	engine guard right	4	150.811	washer Ø10,4
1	700007600	adapter	4	150.810	washer Ø8,4
1	151.155	allen screw M10x85x1,25	1	150.801	self-nock nut M10
1	150.952	allen screw M10x60x1,25	2	150.800	self-nock nut M8
1	150.869	allen screw M10x50	2	151.089	spacer alu Ø20xØ11x13mm



Control all screw connections after the assembling for tightness!
Please notice our enclosed service information.

Also available:

Side carrier (Lock it System, removable)

Rear rack

Center stand

C-Bow Holder for softbags

Item-No. 650.968 00 01

Item-No. 650.968 01 01

Item-No. 505.968

Item-No. 630.968



Hepco & Becker GmbH
An der Steinmauer 6
D-66955 Pirmasens
Germany

Tel.: 0049 6331 - 1453 - 100
Fax: 0049 6331 - 1453 - 120
eMail: vertrieb@hepco-becker.de
www.hepco-becker.de

Engine guard

HONDA Crossrunner

Item - No.:
501.968 00 01 black

Side cases

Top cases

Luggage frames

Lock it system

Softbags

Aluminium luggage

Leather luggage

Protection bars

Center stands

Chopper parts

Accessories



Assembling instructions

Attaching the adapter front:

This is fitted to the cockpit mounting underneath the headlight and above the horn.

Original screw is obsolete.

Fix the adapter to the cockpit mounting with allen screw M10 x 50, self lock nut M10 and washers $\varnothing 10,4$.

Push the adapter all the way up and tighten.

Note: Cover the fender to protect it.

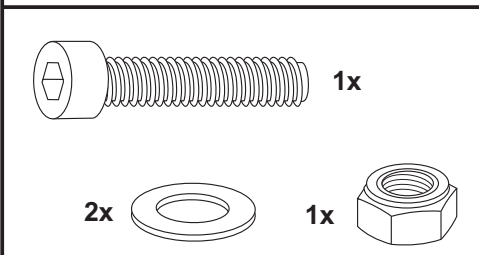

1

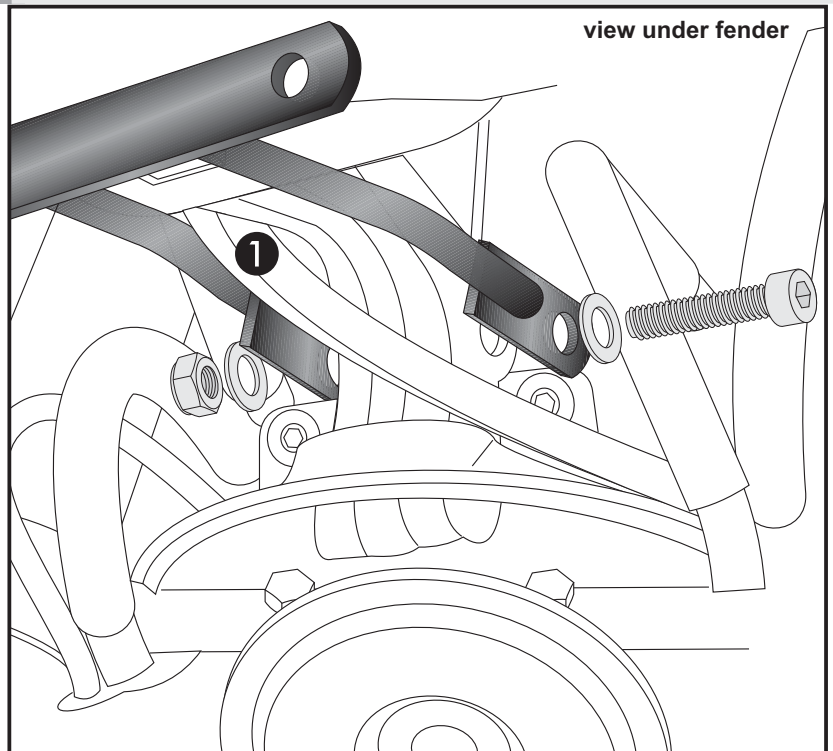

view under fender

Caution:

The two electric cables ① must run between the plates of the adapter.

Assembly tip due to the restricted clearance:

Viewed from the direction of travel, insert the ring spanner from above over the right handlebar and hold the nut in position. Using a small ratchet and allen nut size 8, tighten the screw from below. After fitting the adapter, turn the handlebars all the way to the left and then all the way to the right. As you do so, check that no cables are caught.

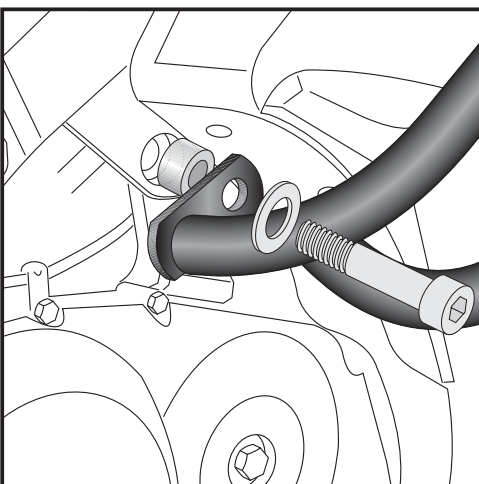

2

Attaching the engine guards left+right:

at the middle engine suspension. Original screws are obsolete.

Put alu spacer $\varnothing 20 \times \varnothing 11 \times 13$ mm in the frame boring left and right. Fix the engine guard left with allen screw M10 x 85 and the right one with allen screws M10x60, both with washers $\varnothing 10,4$.

Only tighten the screws loosely - only after you have fitted the front attachment point should you fully tighten the screws.

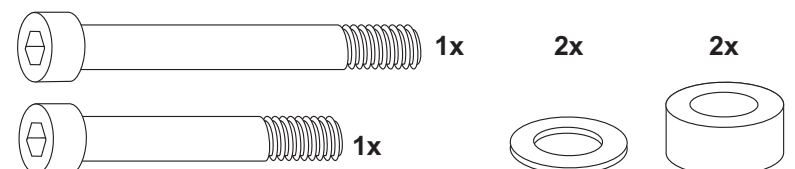

Luggage ideas.

2

Engine guard

HONDA Crossrunner

Item - No.:
501.968 00 01 black

Side cases

Top cases

Luggage frames

Lock it system

Softbags

Aluminium luggage

Leather luggage

Protection bars

Center stands

Chopper parts

Accessories



Assembling instructions

Attaching the engine guards front::

Push the two engine guards together over the covered fender and turn them upwards to bolt them onto the adapter.

3

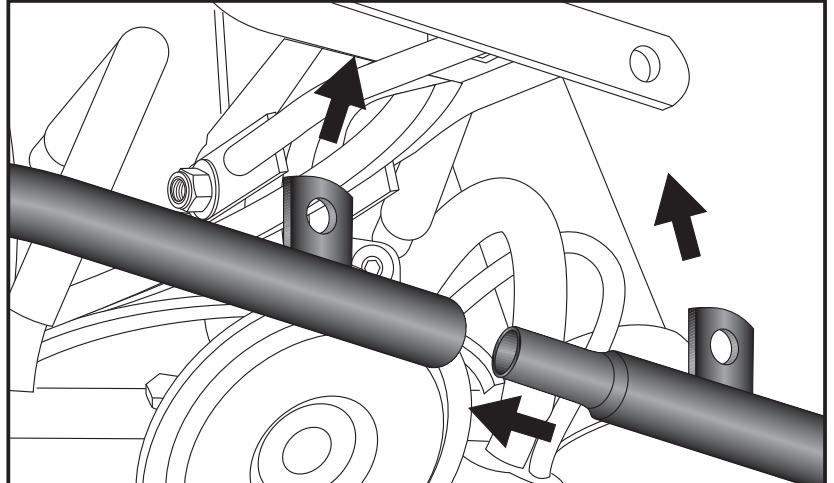

Attaching the engine guards front::

at the adapter with allen screw M8 x 20, self lock nut M8 and washers ø8,4.

3

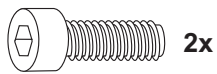
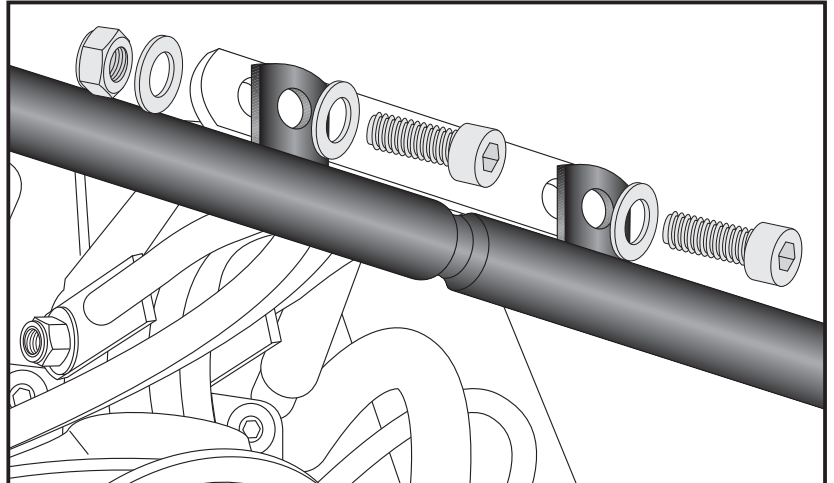

4x



2x

