

Motorschutzbügel HONDA CBF 1000 F

Artikel-Nr.:
501.957 00 01 schwarz

Montage

Der Bausatz umfaßt die folgenden Teile:

Stück	Bestellnr.	Bezeichnung
1	700007189	Motorschutzbügel links
1	700007188	Motorschutzbügel rechts
2	150.870	Inbusschrauben M 10 x 55
4	150.811	U-Scheiben ø10,5
2	150.801	selbstsichernde Muttern M 10
1	151.021	Rundgummifeder 5218 027
2	151.022	selbstsichernde Muttern M 8 DIN 6927

Seitenkoffer
Topcases
Gepäckträger
Lock it System
Softbags
Aluminiumkoffer
Lederkoffer
Schutzbügel
Hauptständer
Chopper-Parts
Quad-Parts
Accessoires

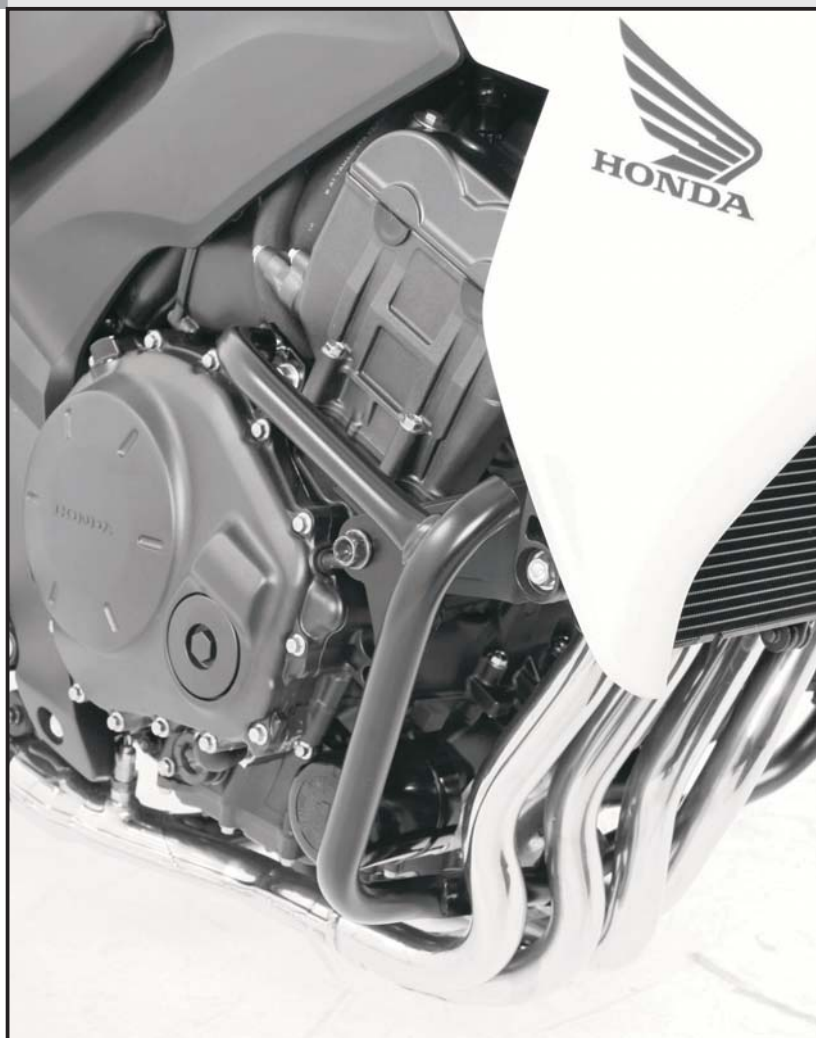

Anzugsmomente des Motorradherstellers beachten!
Nach der Montage alle Verschraubungen auf festen Sitz kontrollieren!
Bitte beachten Sie unsere beigefügten Serviceinformationen.

Als weiteres Zubehör lieferbar:

650.957 01 01 Gepäckbrücke
650.957 00 01 Kofferträger Lock it (abnehmbar)
630.957 C-Bow Softtaschenhalter



Hepco & Becker GmbH
An der Steinmauer 6
D-66955 Pirmasens

Tel.: 06331 - 1453 - 100
Fax: 06331 - 1453 - 120
eMail: vertrieb@hepco-becker.de
www.hepco-becker.de

Motorschutzbügel
HONDA CBF 1000 F

Artikel-Nr.:
501.957 00 01 schwarz

Seitenkoffer
Topcases
Gepäckträger
Lock it System
Softbags
Aluminiumkoffer
Lederkoffer
Schutzbügel
Hauptständer
Chopper-Parts
Quad-Parts
Accessoires



Montage

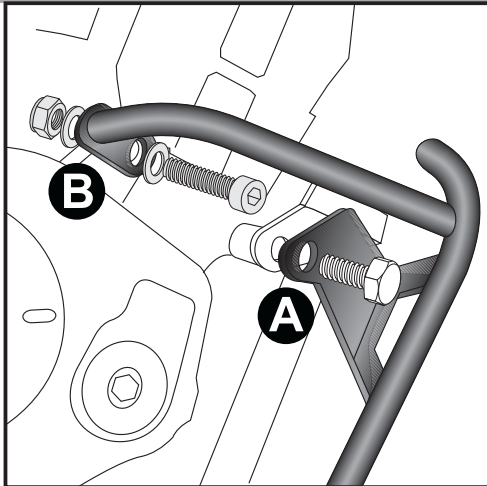

1

Befestigung rechts:

A Außen über den Rahmenlaschen der Motorverschraubung mit den Originalschrauben. Die Original-Unterlegscheiben entfallen.

B An der **Außenseite** des am Motor befindlichen Gewindeblocks mit der Inbusschraube M 10 x 55 nebst U-Scheiben $\varnothing 10,5$ und selbstsichernder Mutter M 10.

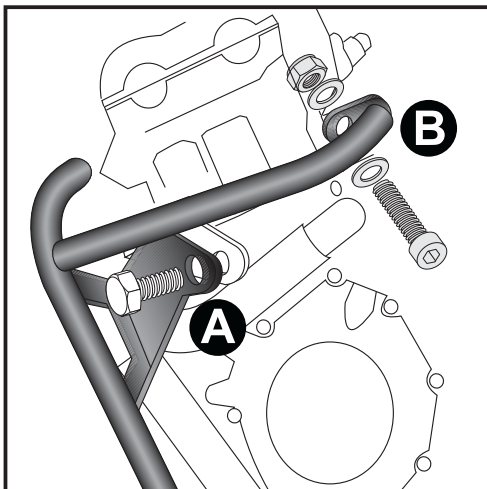

2

Befestigung links:

A Außen über den Rahmenlaschen der Motorverschraubung mit der Originalschraube.

B An der **Außenseite** des am Motor befindlichen Gewindeblocks mit der Schraube M 10 x 55, U-Scheiben $\varnothing 10,5$ und selbstsichernder Mutter M 10.

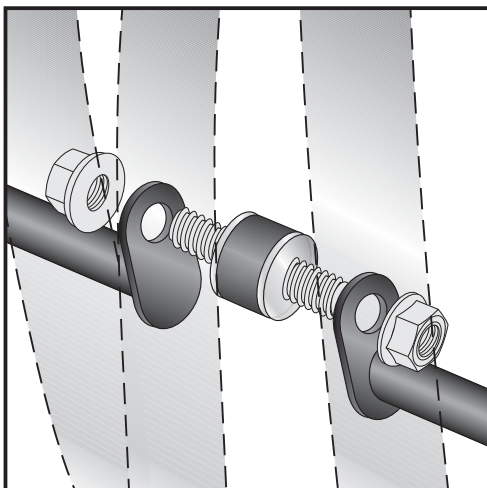

3

Befestigung unten:

Beide Motorschutzbügelhälften werden zwischen Auspuffkrümmer und Motorblock mittels der Rundgummifeder 5218 027 und zwei selbstsichernden Muttern M 8 DIN 6927 verschraubt.



Engine guard
HONDA CBF 1000 F

Item-No.
501.957 00 01 black

Assembling instructions

The kit includes the following parts:

Quant	item no.	description
1	700007189	engine guard left side
1	700007188	engine guard right side
2	150.870	allen screw M 10 x 55
4	150.811	washer ø10,5
2	150.801	self-lock nut M 10
1	151.021	silent block no.5218 027
2	151.022	self-lock nut M8 DIN 6927

Side cases
Top cases
luggage frames
Lock it system
Softbags
Aluminium luggage
Leather luggage
Protection bars
Center stands
Chopper parts
Quad parts
Accessories

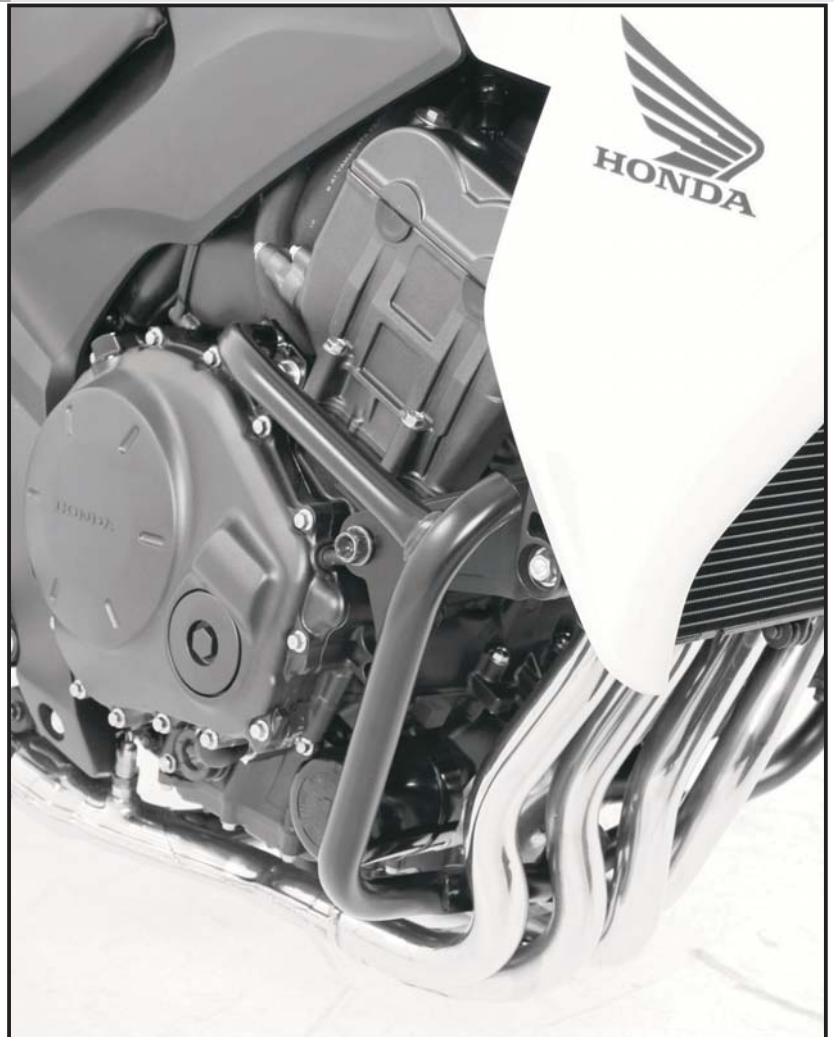

Control all screw connections after the assembling for tightness!
Please notice our enclosed service information.

Also available:

650.957 01 01 Rear rack black
650.957 01 01 Side carrier Lock it (removable)
630.957 C-Bow holder for softbags



Hepco & Becker GmbH
An der Steinmauer 6
D-66955 Pirmasens
Germany

Tel.: +49 6331 - 1453 - 100
Fax: +49 6331 - 1453 - 120
eMail: vertrieb@hepco-becker.de
www.hepco-becker.de

Engine guard
HONDA CBF 1000 F

Item-No.
501.957 00 01 black

- Side cases
- Top cases
- luggage frames
- Lock it system
- Softbags
- Aluminium luggage
- Leather luggage
- Protection bars
- Center stands
- Chopper parts
- Quad parts
- Accessories



Assembling instructions

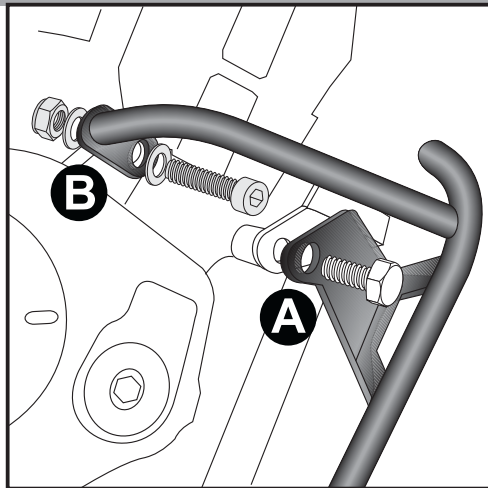

1

Fastening of crash bar right:

A above the engine plate with original screw.
The original washer is obsolete.

B outside of the engine threadblock with allen screw
M 10 x 55, washer $\varnothing 10,5$ and self-lock nut M 10.

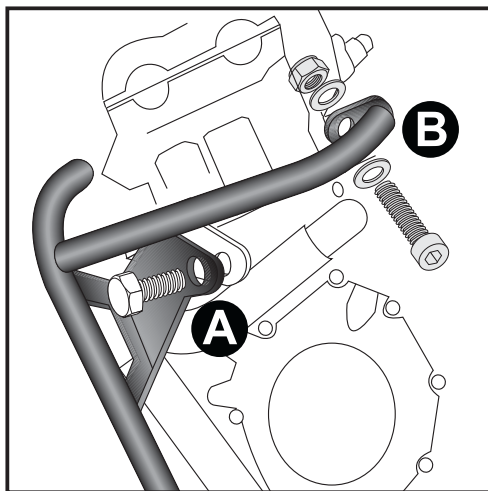

2

Fastening of crash bar left:

A above the engine plate with original screw.

B outside the engine threadblock with allen screw
M 10 x 55, washers $\varnothing 10,5$ and self-lock nut M 10.

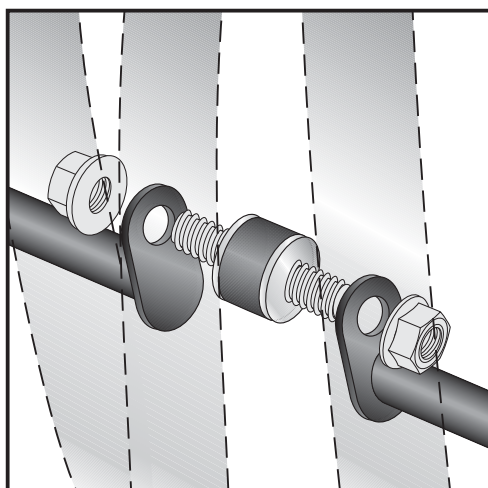

3

Connection of the crash bars:

between exhaust manifold and engine block with silent block no.5218
027 and two self-lock nuts M 8 DIN 6927.

