

Motorschutzbügel

KRAUSER[®]

MOTORRADGEPÄCKSYSTEME ■ BIKE BAGS

KAWASAKI ER-6n
ab Bj. 2012

Artikel-Nr.:
3002.043.101
schwarz



KAWASAKI ER-6n
ab Bj. 2012

Artikel-Nr.:
501.2516 00 01
schwarz

Montage

Der Bausatz umfaßt die folgenden Teile:

Stück	Bestellnr.	Bezeichnung
1	700007851	Motorschutzbügel links
1	700007852	Motorschutzbügel rechts
1	151.232	Inbusschraube M10 x180
2	150.782	Linsenkopfschraube M8 x 20
2	150.811	U-Scheibe ø10,5
4	150.810	U-Scheibe ø8,4
1	150.801	Selbtsichernde Mutter M10
2	150.800	Selbtsichernde Mutter M8

Tipp:

Schrauben sie alle Teile an und lassen sie die zugänglichen Schrauben etwas locker. Nachdem alles montiert ist, werden alle Schrauben auf das entsprechende Anzugsmoment angezogen. Dadurch wird sicher-gestellt, dass das Produkt spannungsfrei angebaut ist. Damit ist eine lange Lebensdauer sichergestellt !



Motorschutzbügel



MOTORRADGEPÄCKSYSTEME ■ BIKE BAGS

KAWASAKI ER-6n
ab Bj. 2012

Artikel-Nr.:
3002.043.101
schwarz



KAWASAKI ER-6n
ab Bj. 2012

Artikel-Nr.:
501.2516 00 01
schwarz

Montage

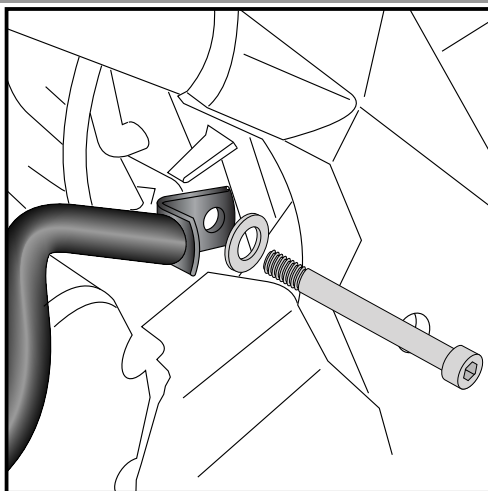

1

Vorbereitende Arbeiten:

Rahmenverkleidung rechts demontieren. Verkleidung rechts und links vorne am Kühler, untere Befestigungsschraube lösen.

Befestigung der Motorschutzbügel hinten links:

An der hinteren Motoraufhängung.

Originalschraube ausdrehen, sie entfällt.

Zur Befestigung die Inbusschraube M10x180 mm mit U-Scheibe Ø10,5 verwenden.

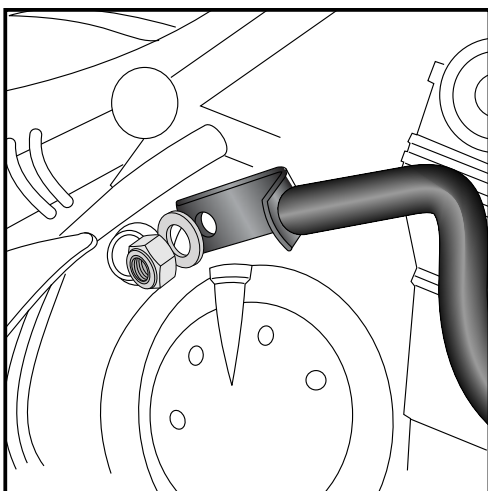
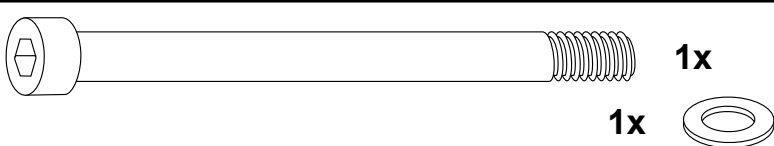

2

Befestigung der Motorschutzbügel hinten rechts:

An der in Schritt 1 montierten Schraube.

Zur Befestigung die U-Scheibe Ø10,5 und selbstsichernde Mutter M10 verwenden.

Achtung: Nicht den Ablaufschlauch klemmen.

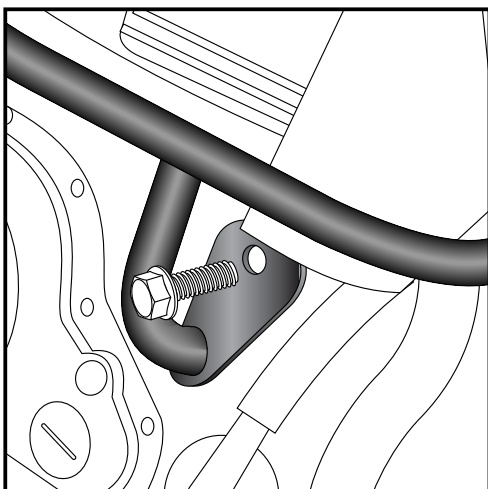

3

Befestigung der Motorschutzbügel vorne links und rechts:

An der Motoraufhängung am Rahmen mit den Originalschrauben.

Motorschutzbügel



KAWASAKI ER-6n
ab Bj. 2012

Artikel-Nr.:
501.2516 00 01
schwarz



MOTORRADGEPÄCKSYSTEME ■ BIKE BAGS

KAWASAKI ER-6n
ab Bj. 2012

Artikel-Nr.:
3002.043.101
schwarz

Montage

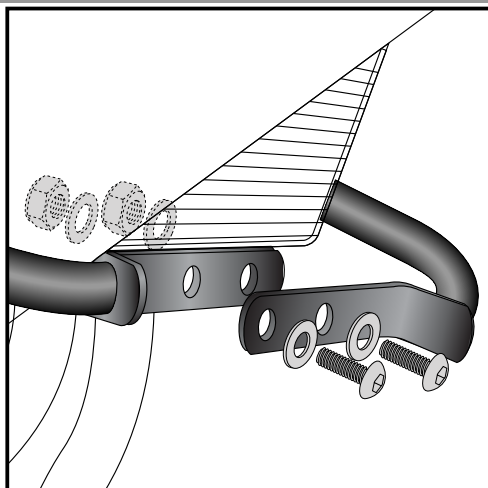

4

Befestigung der Motorschutzbügel vorne vor dem Kühler:

Die Motorschutzbügel so montieren, das die Lasche des rechten Motorschutzbügels vor dem Kühler in Fahrtrichtung hinter dem linken positioniert ist. Die Verschraubung erfolgt mit den Linsenkopfschrauben M8x20 sowie U-Scheiben Ø8,4 und selbstsichernden Muttern M8.

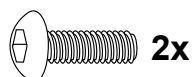

Nach der Montage alle Verschraubungen auf festen Sitz kontrollieren!
Bitte beachten Sie unsere beigefügten Serviceinformationen.

Weiteres Zubehör:

Hepco & Becker

Krauser

Kofferträger	Art.-Nr. 650.2516 00 01
Gepäckbrücke	Art.-Nr. 650.2516 01 01
C-Bow Halter für Softtaschen	Art.-Nr. 630.2516

Art.-Nr. 4002.043.111
Art.-Nr. 4002.043.201
Art.-Nr. 3002.043.131



Hepco & Becker GmbH
An der Steinmauer 6
D-66955 Pirmasens
Tel.: 06331 - 1453 - 100
Fax: 06331 - 1453 - 120
eMail: vertrieb@hepco-becker.de
www.hepco-becker.de



Krauser GmbH
An der Steinmauer 6
D-66955 Pirmasens
Tel.: 06331 - 1453 - 250
Fax: 06331 - 1453 - 260
eMail: vertrieb@krauser.de
www.krauser.de

Engine guard

KRAUSER[®]

MOTORRADGEPÄCKSYSTEME ■ BIKE BAGS

KAWASAKI ER-6n
from 2012

Item-No.:
3002.043.101
black



KAWASAKI ER-6n
from 2012

Item-No.:
501.2516 00 01
black

Assembling instructions

The kit includes the following parts:

Quant	item no.	description
1	700007851	crash bar left
1	700007852	crash bar right
1	151.232	allen screw M10 x180
2	150.782	filister head screw M8 x 20
2	150.811	washer ø10,5
4	150.810	washer ø8,4
1	150.801	self-lock nut M10
2	150.800	self-lock nut M8

Tip:

Fit all parts and screw on not too strong.
After mounting all parts, the screws should be tightened to the torque specified.
This guarantees, that the kit is mounted without tension.



Engine guard



KAWASAKI ER-6n
from 2012

Item-No.:
501.2516 00 01
black



MOTORRADGEPÄCKSYSTEME ■ BIKE BAGS

KAWASAKI ER-6n
from 2012

Item-No.:
3002.043.101
black

Assembling instructions

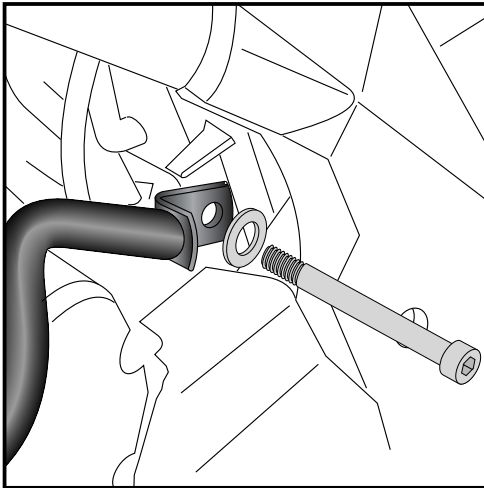

1

Preparing:

Unmount the right plastic frame cover.
Loose the upper screw of the plastic cooler cover left and right.

Fastening of crash rear left:

At the rear engine bolting.

Original screw is obsolete.

Use allen screw M10x180 with washer Ø10,5 for fixing.

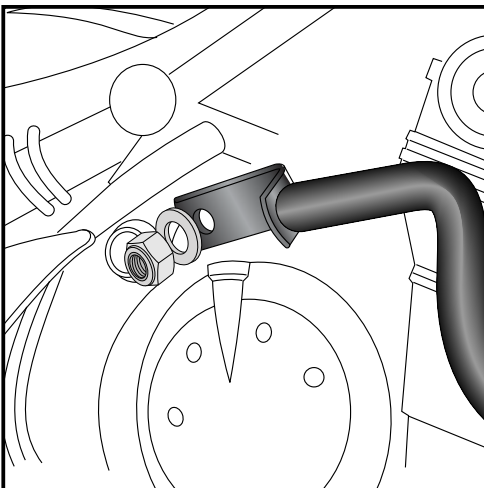
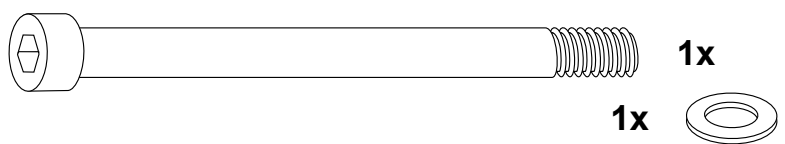

2

Fastening of crash rear right:

At the allen screw, mounted in step 1.

Use washer Ø10,5 and self lock nut M10.

Caution: Do not pinch the drain hose.

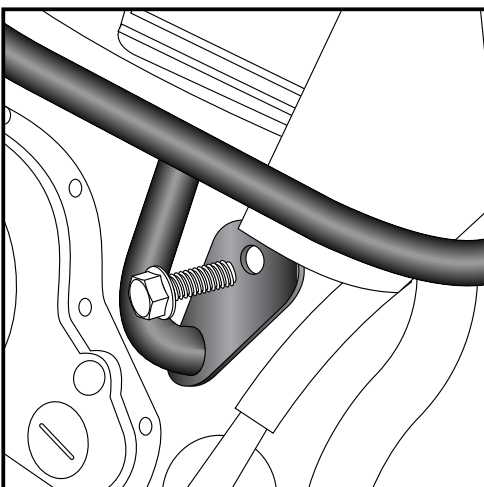

3

Fastening of crash front left + right:

At the engine suspension at the frame with original screws.

Engine guard



KAWASAKI ER-6n
from 2012

Item-No.:
501.2516 00 01
black



MOTORRADGEPÄCKSYSTEME ■ BIKE BAGS

KAWASAKI ER-6n
from 2012

Item-No.:
3002.043.101
black

Assembling instructions

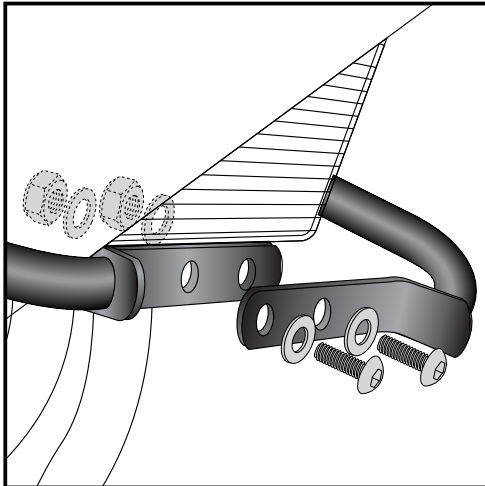

4

Fastening of crash bar in front of the cooler:

Notice: the shackle of the right crash bar is behind the shackle of the left crash bar

Fix them with filister head screws M 8 x 20 and washers ø8,4.
Backside: self lock nuts M 8 with washers ø8,4.

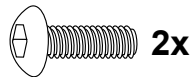

Control all screw connections after the assembling for tightness!
Please notice our enclosed service information.

Also available:

Hepco & Becker

Krauser

Side carrier	Item-No. 650.2516 00 01
Rear rack	Item-No. 650.2516 01 01
C-Bow holder for Softbgs	Item-No. 630.2516

Item-No. 4002.043.111
Item-No. 4002.043.201
Item-No. 3002.043.131



Hepco & Becker GmbH
An der Steinmauer 6
D-66955 Pirmasens
Tel.: 0049 6331 - 1453 - 100
Fax: 0049 6331 - 1453 - 120
eMail: vertrieb@hepco-becker.de
www.hepco-becker.de



Krauser GmbH
An der Steinmauer 6
D-66955 Pirmasens
Tel.: 0049 6331 - 1453 - 250
Fax: 0049 6331 - 1453 - 260
eMail: vertrieb@krauser.de
www.krauser.de