

Motorschutzbügel

KAWASAKI VN 1700 Classic

Artikel-Nummer:
501.234 00 02 chrom

Seitenkoffer
Topcases
Gepäckträger
Lock it System
Softbags
Aluminiumkoffer
Lederkoffer
Schutzbügel
Hauptständer
Chopper-Parts
Quad-Parts
Accessoires



Montage

Der Bausatz umfaßt die folgenden Teile:

Stück	Bestellnr.	Bezeichnung
1	702.516HB	Sturzbügel links
1	702.517HB	Sturzbügel rechts
1	702.518HB	Querstrebe
2	150.938	Linsenkopfschraube M8x20
1	150.830	Sechskantschraube M6x25
2	151.163	Inbusschraube M10x70 Steigung 1,25
2	150.811	U-Scheibe Ø10,5
2	150.810	U-Scheibe Ø8,4
1	150.809	U-Scheibe Ø6,4

**Achtung: Sturzbügelhälften
immer nur wechselseitig
montieren da die Gefahr der
Motorabsenkung besteht.**

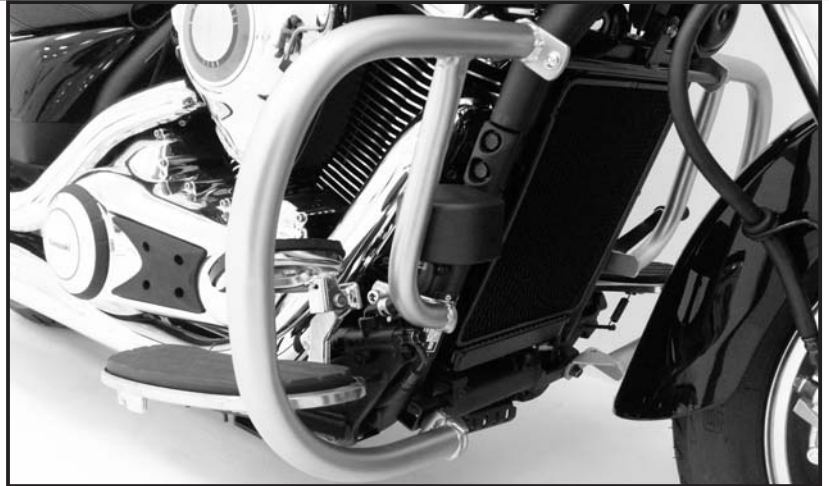

Anzugsmomente des Motorradherstellers beachten!
Nach der Montage alle Verschraubungen auf festen Sitz kontrollieren!
Bitte beachten Sie unsere beigefügten Serviceinformationen.

Weiteres lieferbares Zubehör:

Packtaschenhalter C-Bow	Nr. 625.234 chrom	Kofferträger	Nr. 650.234 00 02 chrom
Sissybar mit Gepäckbrücke	Nr. 611.234 chrom	Sissybar ohne Gepäckbrücke	Nr. 600.234 chrom
Twinlights	Nr. 400.234 chrom	Gepäckbrücke	Nr. 650.234 01 02 chrom



Hepco & Becker GmbH
An der Steinmauer 6
D-66955 Pirmasens

Tel.: 06331 - 1453 - 100
Fax: 0)6331 - 1453 - 120
eMail: vertrieb@hepco-becker.de
www.hepco-becker.de

Motorschutzbügel

KAWASAKI VN 1700 Classic

Artikel-Nummer:
501.234 00 02 chrom

- Seitenkoffer
- Topcases
- Gepäckträger
- Lock it System
- Softbags
- Aluminiumkoffer
- Lederkoffer
- Schutzbügel
- Hauptständer
- Chopper-Parts
- Quad-Parts
- Accessoires



Montage

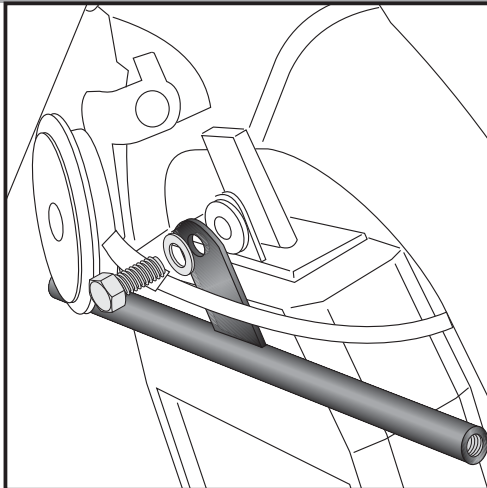

1

Montage der Querstrebe oben:
Obere Kühlerverschraubung entfernen.
Querstrebe mit der Lasche über der über der Gewindebohrung positionieren und mit der Sechskantschraube M6x25 und der U-Scheibe Ø6,4 handfest verschrauben.

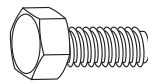

1x



1x

Montage des Motorschutzbügels:
Die Verschraubung der unteren Rahmenstrebe und der unteren Motorverschraubung entfernen.
Sturzbügelhälfte über den freien Bohrungen positionieren und handfest verschrauben.

Mitte: ①
mit Inbusschraube M10x70 Steigung 1,25 und U-Scheibe Ø10,5.

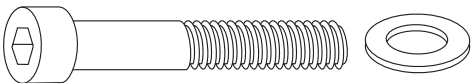

2x

2x

Unten: ②
mit der Originalschraube

Oben: ③
mit der Linsenkopfschraube M8x20 und die U-Scheibe Ø8,4 die Querstrebe mit der Sturzbügelhälfte verbinden.

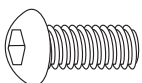

2x



2x

Mit der anderen Sturzbügelhälfte genauso verfahren.
Jetzt alle Verschraubungspunkte festziehen und nochmals kontrollieren.

2

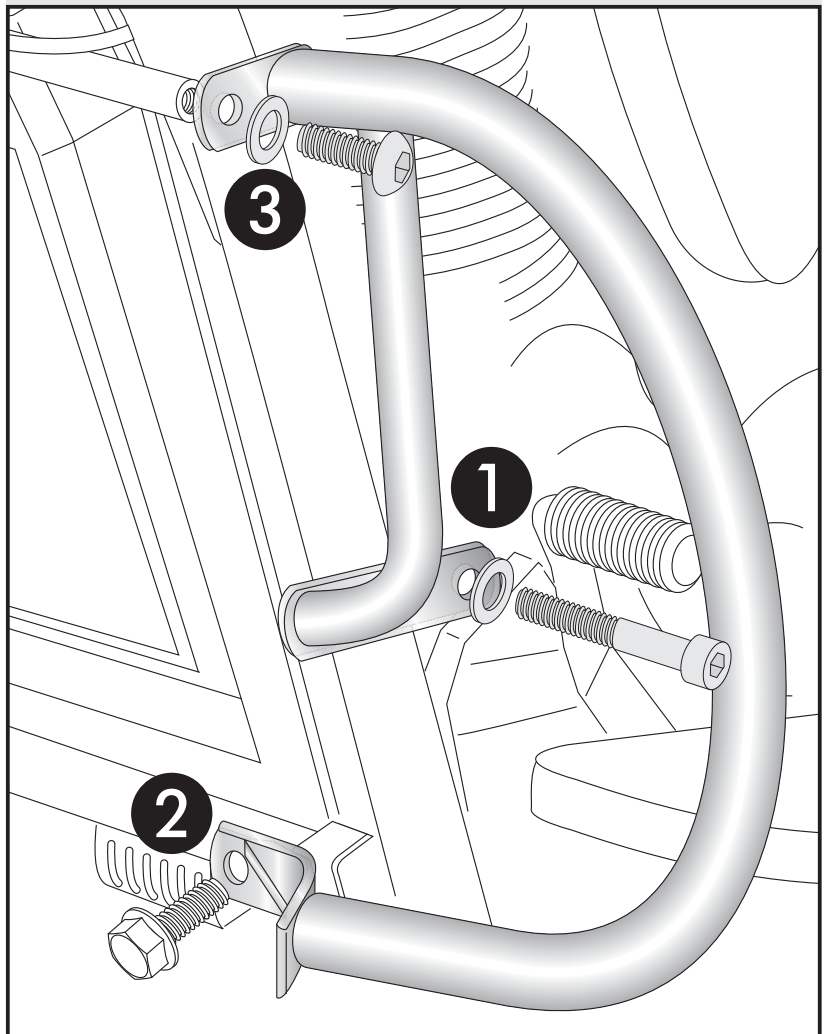

Engine guard

KAWASAKI VN 1700 Classic

Item-no.:

501.234 00 02 chrome

Side cases

Top cases

luggage frames

Lock it system

Softbags

Aluminium luggage

Leather luggage

Protection bars

Center stands

Chopper parts

Quad parts

Accessories



**HEPCO &
BECKER**

Assembling instructions

The kit includes the following parts:

Quant	item no.	description
1	702.516HB	engine guard right
1	702.517HB	engine guard left
1	702.518HB	bracing bow
2	150.938	filister head screw M8x20
1	150.830	hexagon bolt M6x25
2	151.163	allen screw M10x70 x 1,25
2	150.811	washer Ø10,5
2	150.810	washer Ø8,4
1	150.809	washer Ø6,4

WARNING:

Do it side by side, starting with the left side. Otherwise the engine block can move down.

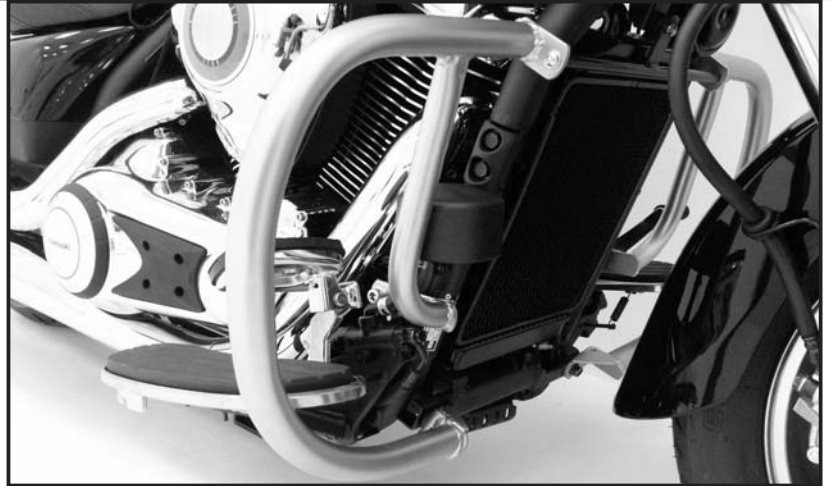

Control all screw connections after the assembling for tightness!
Please notice our enclosed service information.

Also available:

Leather bag holder C-Bow

Item-no.: 625.234

Side carrier

Item-no.: 650.234 00 02

Sissybar with rear rack

Item-no.: 611.234

Sissybar without rear rack

Item-no.: 600.234

Twinlights

Item-no.: 400.234

Rear rack chrome

Item-no.: 650.234 01 02



Hepco & Becker GmbH
An der Steinmauer 6
D-66955 Pirmasens
Germany

Tel.: +49 6331 - 1453 - 100
Fax: +49 6331 - 1453 - 120
eMail: vertrieb@hepco-becker.de
www.hepco-becker.de

Engine guard

KAWASAKI VN 1700 Classic

Item-no.:
501.234 00 02 chrome

Side cases

Top cases

Luggage frames

Lock it system

Softbags

Aluminium luggage

Leather luggage

Protection bars

Center stands

Chopper parts

Quad parts

Accessories



Assembling instructions

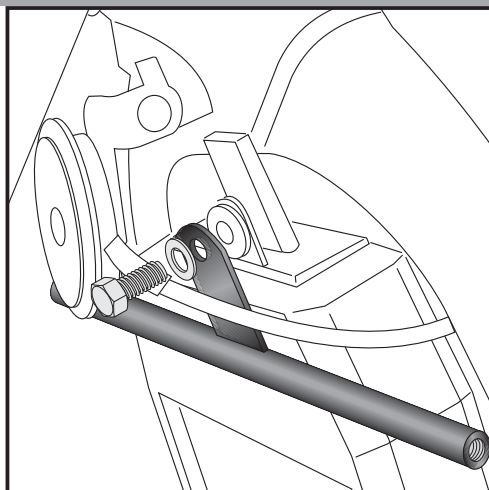

1 Fastening of the bracing bow top:
Unscrew top cooler bolting.
Fix the bracing bow at the free threaded hole with hexagon bolt M6x25 and washer Ø6,4.

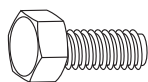

1x

1x



Fastening of the engine guard:
Unscrew bottom frame bolting and bottom engine bolting.

Fix the engine guard with the following screws:

middle: **1**
with allen screw M10x70 x1,25 and washer Ø10,5.

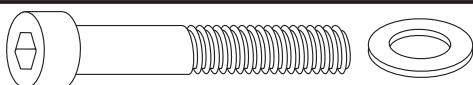

2x

2x

bottom: **2**
with original screw

top: **3**
with filister head screw M8x20 and washer Ø8,4 to the bracing bow.

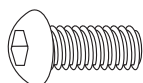

2x



2x

Continue with the other side in the same sequence.

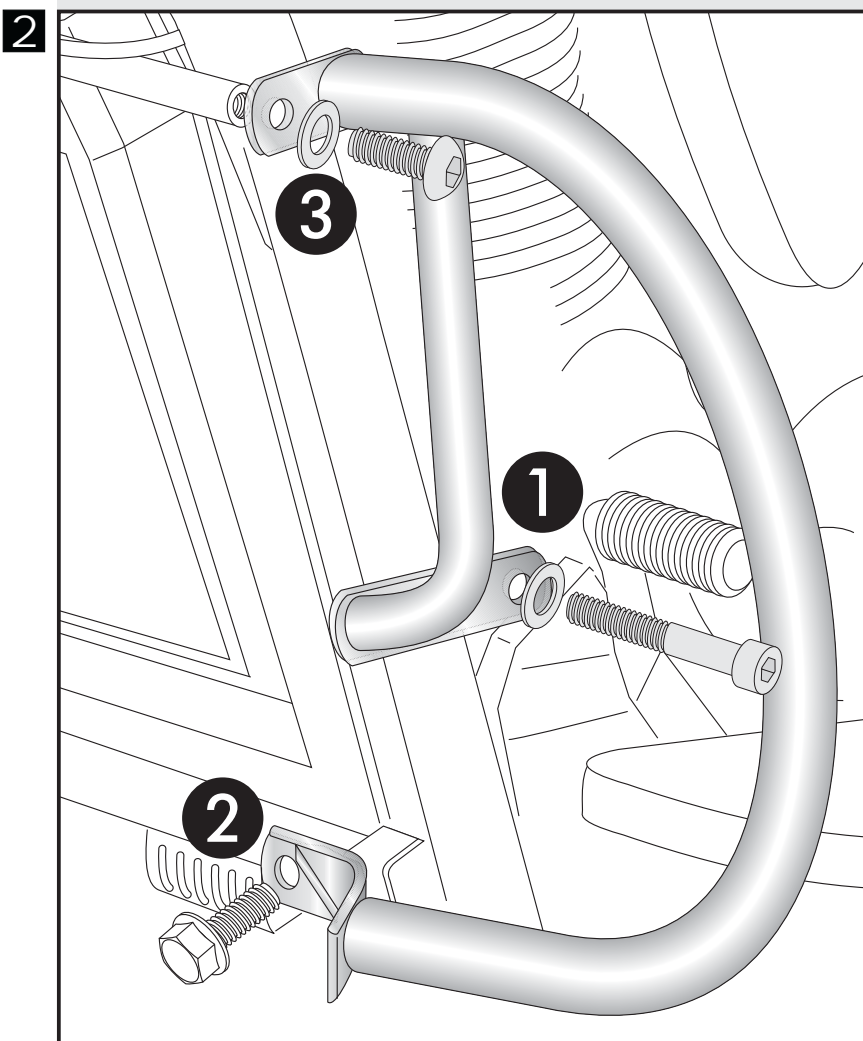

Luggage ideas.