

Motorschutzbügel

KTM 125/200 Duke

Art.-Nr.: 501.7504 schwarz



KTM 125 Duke
Art.-Nr.: 3011.006.101 schwarz

KTM 200 Duke
Art.-Nr.: 3011.009.101 schwarz

Montage

Der Bausatz umfaßt die folgenden Teile:

Stück	Bestellnr.	Bezeichnung	Stück	Bestellnr.	Bezeichnung
1	700008285	Motorschutzbügel	4	150.824	Aludistanzen Ø18xØ9x15mm
4	150.785	Inbusschrauben M8x35	1	151.417	Aludistanzen Ø18xØ11x17mm
1	151.277	Inbusschrauben M10x140	4	150.810	U-Scheibe Ø8,4
			2	150.811	U-Scheibe Ø10,5
			1	150.801	selbstsichernde Muttern M10



Anzugsmomente des Motorradherstellers beachten!
Nach der Montage alle Verschraubungen auf festen Sitz kontrollieren!
Bitte beachten Sie unsere beigefügten Serviceinformationen.



Hepco & Becker GmbH
An der Steinmauer 6
D-66955 Pirmasens
Tel.: 06331 - 1453 - 100
Fax: 06331 - 1453 - 120
eMail: vertrieb@hepco-becker.de
www.hepco-becker.de



Krauser GmbH
An der Steinmauer 6
D-66955 Pirmasens
Tel.: 06331 - 1453 - 250
Fax: 06331 - 1453 - 260
eMail: vertrieb@krauser.de
www.krauser.de

Motorschutzbügel



KTM 125/200 Duke

Art.-Nr.: 501.7504 schwarz

KTM 125 Duke
Art.-Nr.: 3011.006.101 schwarz

KTM 200 Duke
Art.-Nr.: 3011.009.101 schwarz

Montage

Vorbereitung:

Die Schrauben der Motorhalterung am Rahmen und am Motor demontieren.
(Motor zur Sicherheit unterbauen)
Motorschutzbügel unterhalb des Kühlers einführen .

Montage des Motorschutzbügels oben rechts und links:

In den Motorhalter die Aludistanzen 18 x 9 x 15 mm einsetzen und den Motorschutzbügel mit den Inbusschrauben M8 x 35 und U – Scheiben Ø8,4 anschrauben.
Montage rechts und links gleich.

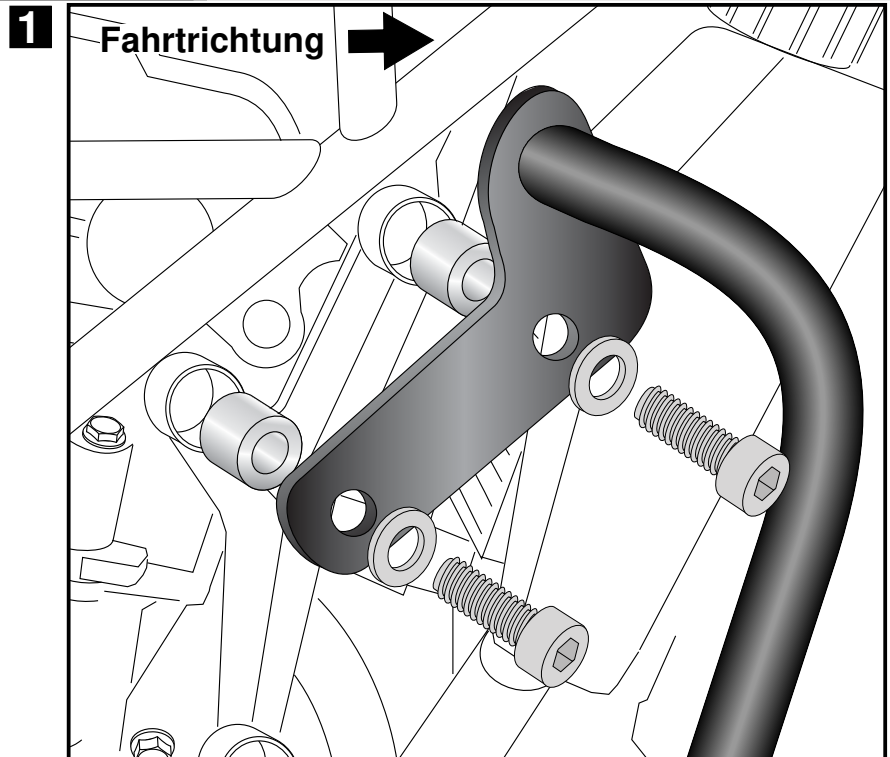
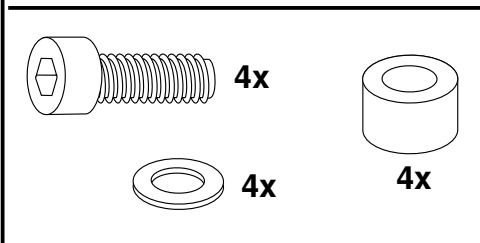

Montage des Motorschutzbügels unten:

Die Originalschraube, die den Motor mit der Motorhalterung verbindet, durch die Inbusschraube M10 X 140 und U – Scheibe Ø10,5 ersetzen. ①

In den Halter in Fahrtrichtung rechts die Aludistanz 18 x 11 x 17 einsetzen und mit U – Scheibe Ø10,5 und selbstsichernder Mutter M 10 verschrauben. ②

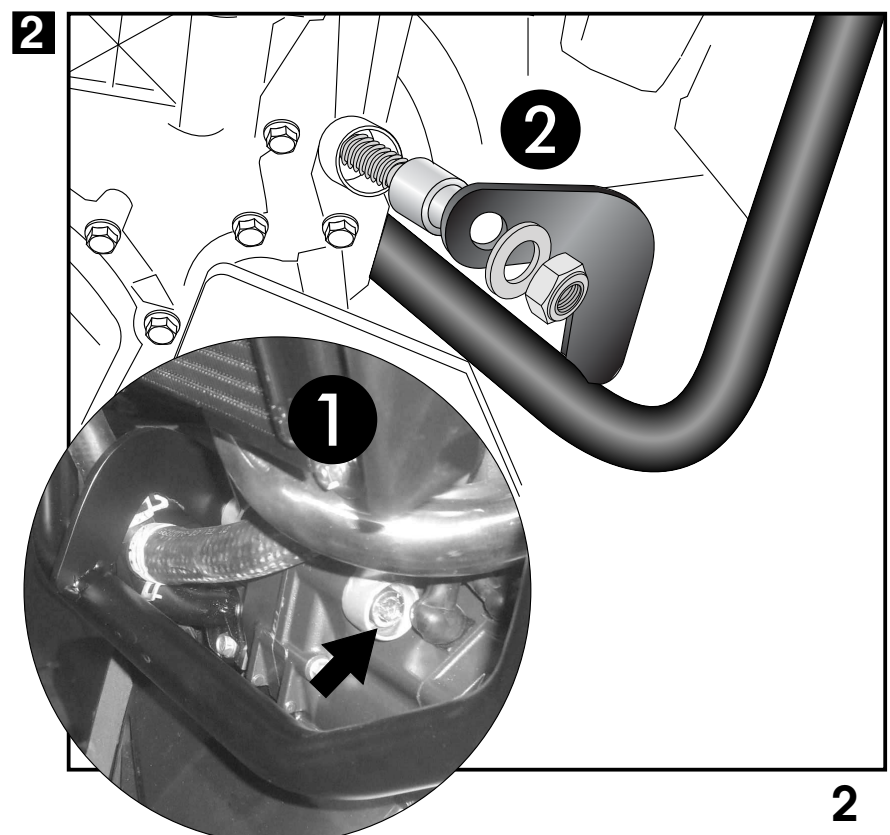
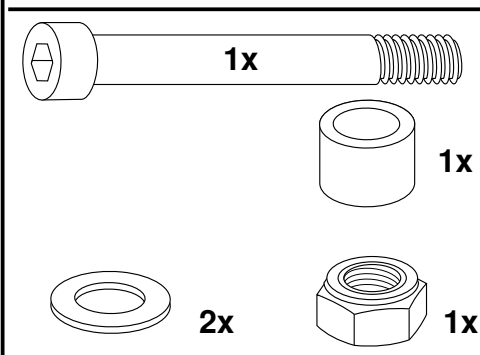



Engine guard

KTM 125 Duke
Item - No.: 3011.006.101 black

KTM 125/200 Duke

KTM 200 Duke
Item - No.: 3011.009.101 black

Item - No.: 501.7504 black

Assembling instructions

The kit includes the following parts:

Quant	item no.	description	Quant	item no.	description
1	700008285	engine guard	4	150.824	alu spacer Ø18xØ9x15mm
4	150.785	allen screw M8x35	1	151.417	alu spacer Ø18xØ11x17mm
1	151.277	allen screw M10x140	4	150.810	washer Ø8,4
			2	150.811	washer Ø10,5
			1	150.801	self lock nut M10



Control all screw connections after the assembling for tightness!
Please notice our enclosed service information.



Hepco & Becker GmbH
An der Steinmauer 6
D-66955 Pirmasens
Tel.: +49 6331 - 1453 - 100
Fax: +49 6331 - 1453 - 120
eMail: vertrieb@hepco-becker.de
www.hepco-becker.de



Krauser GmbH
An der Steinmauer 6
D-66955 Pirmasens
Tel.: +49 6331 - 1453 - 250
Fax: +49 6331 - 1453 - 260
eMail: vertrieb@krauser.de
www.krauser.de



Engine guard

KTM 125/200 Duke

Item - No.: 501.7504 black

KTM 125 Duke

Item - No.: 3011.006.101 black

KTM 200 Duke

Item - No.: 3011.009.101 black

Assembling instructions

Preparing:

Dismantle the screws of the engine block bolting at the frame.

(Support engine for security reasons)

Fastening of the engine guard top right and left:

Add alu spacers 18 x 9 x 15 mm into the engine support borings and fix the engine guard with allen screws M8 x 35 with washers Ø8,4. Mount left and right alike.

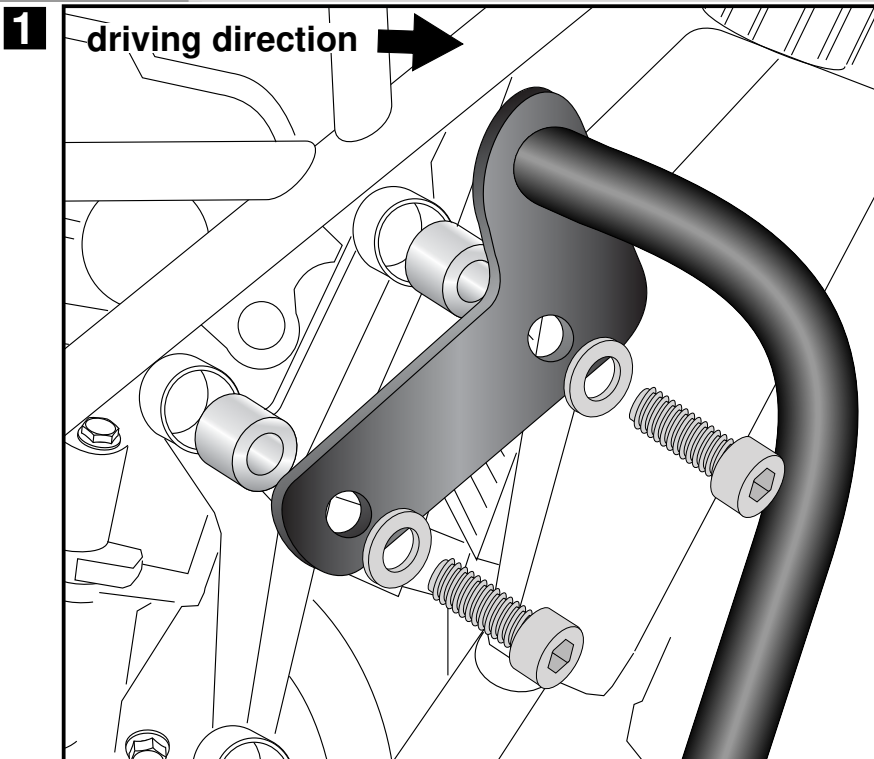
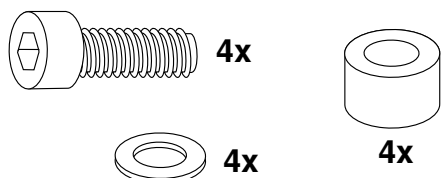

Fastening of the engine guard bottom:

Change original screw, connecting the motor to the motor bracket, with allen screw M10 X 140 and washer Ø10,5. ①

Add alu spacers 18 x 11 x 17 mm into the right engine support boring and fix the engine guard at the thread of the allen screw with washer Ø10,5 and self lock nut M 10. ②

