

**Motorschutzbügel  
Suzuki GSF 650 Bandit  
ab Bj. 07**

**Art.-Nr.: 501.325 00 01 schwarz**

Seitenkoffer  
Topcases  
Gepäckträger  
Lock it System  
Softbags  
Aluminiumkoffer  
Lederkoffer  
Schutzbügel  
Hauptständer  
Chopper-Parts  
Quad-Parts  
Accessoires



**Montage**

| Stück | Bestellnr. | Bezeichnung                                   |
|-------|------------|---|
| 1     | 703.507HB  | Motorschutzbügel links                        |
| 1     | 703.508HB  | Motorschutzbügel rechts                       |
| 1     | 703.509HB  | Versteifungsstrebe (M8 Innengewinde)          |
| 1     | 703.274    | Adapter, klein (links)                        |
| 1     | 150.860    | Inbusschraube M10 x 30                        |
| 1     | 151.110    | Inbusschraube M10 x 55 x 1,25 Festigkeit 10,9 |
| 1     | 150.841    | Inbusschraube M10 x 1,25 x 220                |
| 2     | 150.780    | Inbusschrauben M8 x 16                        |
| 5     | 150.811    | U-Scheiben ø10,5                              |
| 2     | 150.810    | U-Scheibe ø8,4                                |
| 2     | 150.805    | Sprengring ø8,4                               |
| 1     | 151.030    | Distanz ø25 x ø11 x 7                         |
| 1     | 151.050    | selbstsichernde Mutter M 10                   |
| 1     | 151.051    | selbstsichernde Mutter M 10 x 1,25            |

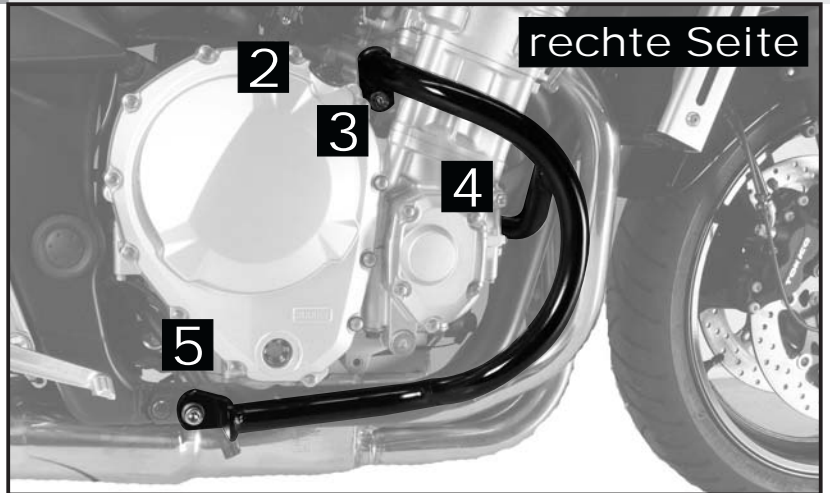

rechte Seite

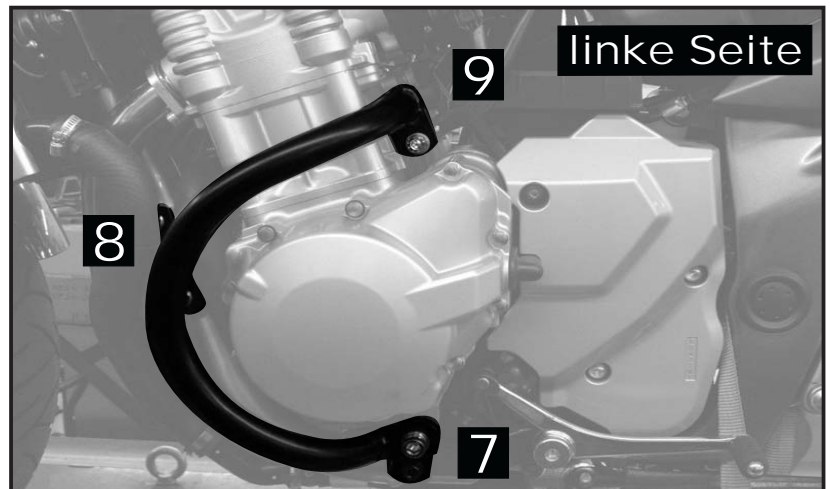

linke Seite

**Anzugsmomente des Motorradherstellers beachten!**

**Nach der Montage alle Verschraubungen auf festen Sitz kontrollieren!**

**Bitte beachten Sie unsere beigefügten Serviceinformationen.**

Als weiteres Zubehör lieferbar:

- 650.3512 00 01 Kofferträger schwarz "Lock it System" (abnehmbar)
- 650.3512 01 01 Gepäckbrücke schwarz



**Hepco & Becker GmbH  
An der Steinmauer 6**

**D-66955 Pirmasens**

**Tel.: 06331 - 1453 - 100**

**Fax: 06331 - 1453 - 120**

**eMail: [vertrieb@hepco-becker.de](mailto:vertrieb@hepco-becker.de)**

**[www.hepco-becker.de](http://www.hepco-becker.de)**

Motorschutzbügel  
Suzuki GSF 650 Bandit  
ab Bj. 07

Art.-Nr.: 501.325 00 01 schwarz

Seitenkoffer  
Topcases  
Gepäckträger  
Lock it System  
Softbags  
Aluminiumkoffer  
Lederkoffer  
Schutzbügel  
Hauptständer  
Chopper-Parts  
Quad-Parts  
Accessoires



## Montage

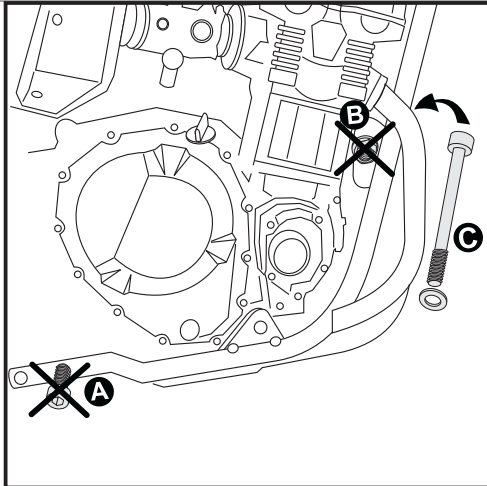

### 1 rechte Seite

#### Vorbereitung:

Demontieren sie die Inbusschraube an der vorderen Rahmenverschraubung. Diese Schraube **A** entfällt.

Anschließend lösen sie am rechten Rahmenunterzug (vor dem Motor) die Mutter (SW 14) **B** und ziehen sie die Schraube heraus.

Achtung, Schraube kann sich mitdrehen, bitte gegenhalten!

Ersetzen sie diese mit der mitgelieferten Inbusschraube M10x1,25x220 **C** inkl. der U-Scheibe  $\varnothing 10,5$ .

Schraube wird von links nach rechts durchgeschoben.

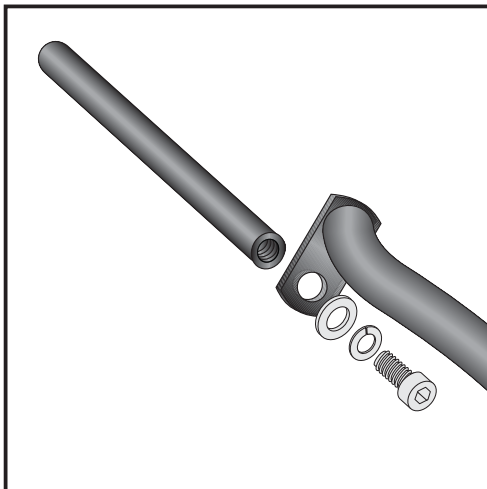
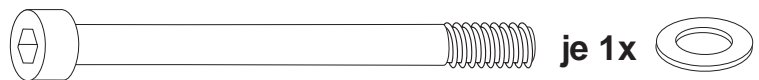

### 2 Montieren der Verstärkungsstrebe:

Montieren sie am Motorschutzbügel rechts die Verstärkungsstrebe mit der Inbusschraube M8 x 16, der U-Scheibe  $\varnothing 8,4$  und dem Sprengling  $\varnothing 8,4$ .

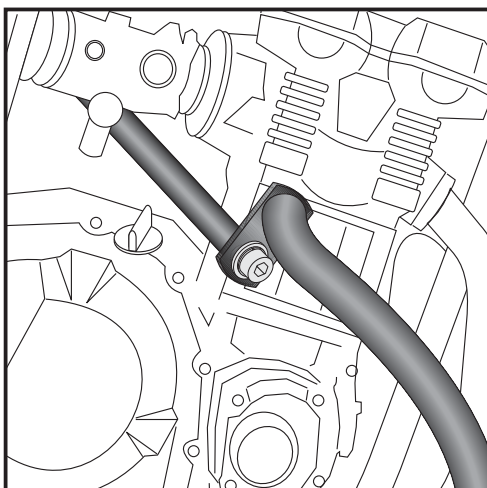

### 3 Nun fügen sie diese an das Motorrad indem sie zunächst die Verstärkungsstrebe hinter dem Motor hindurch schieben.

Motorschutzbügel  
Suzuki GSF 650 Bandit  
ab Bj. 07

Art.-Nr.: 501.325 00 01 schwarz

Seitenkoffer  
Topcases  
Gepäckträger  
Lock it System  
Softbags  
Aluminiumkoffer  
Lederkoffer  
Schutzbügel  
Hauptständer  
Chopper-Parts  
Quad-Parts  
Accessoires



Montage

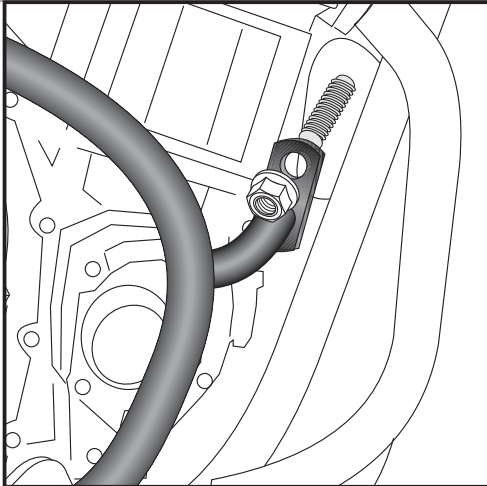

4 rechte Seite

Montage des rechten Motorschutzbügels:  
Führen sie jetzt den rechten Motorschutzbügel über das überstehende Schraubenende aus Montageschritt 1 und drehen sie die Originalmutter wieder auf. Gegenhalten!

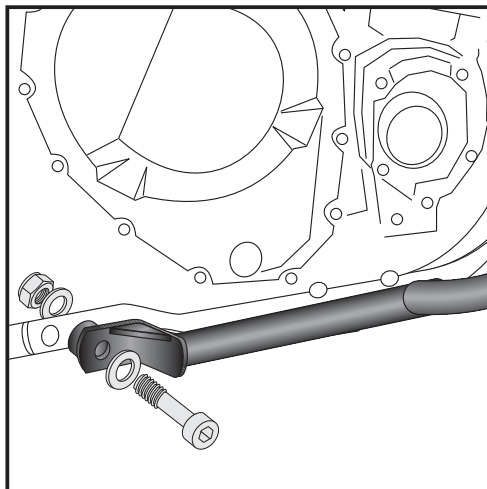

5 Montage des rechten Motorschutzbügels:  
Montieren sie den langen Adapter mit der Inbusschraube M10 x 55 x 1,25, U-Scheiben  $\varnothing 10,5$  und selbstsichernder Mutter M10 x 1,25 an der vorderen Schraube der Rahmenverschraubung. HINWEIS: Mutter mit Feingewinde

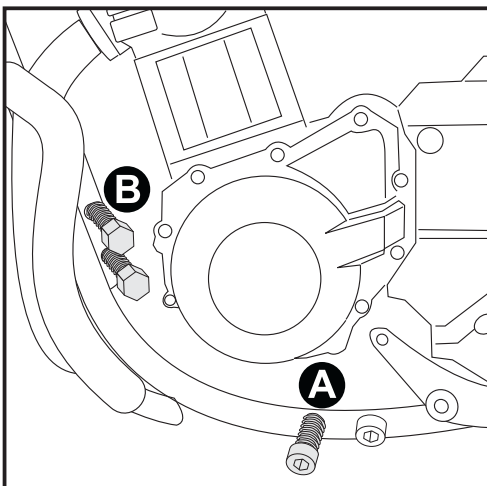

6 linke Seite

Vorbereitung:  
Demontieren sie die Inbusschraube **A** unten am Rahmenunterzug. Ebenfalls zu demontieren sind die beiden Sechskantschrauben (SW 12) **B** am linken Rahmenunterzug vor dem Motor. Die Originalschrauben werden wieder verwendet.

Motorschutzbügel  
Suzuki GSF 650 Bandit  
ab Bj. 07

Art.-Nr.: 501.325 00 01 schwarz

Seitenkoffer  
Topcases  
Gepäckträger  
Lock it System  
Softbags  
Aluminiumkoffer  
Lederkoffer  
Schutzbügel  
Hauptständer  
Chopper-Parts  
Quad-Parts  
Accessoires



Montage

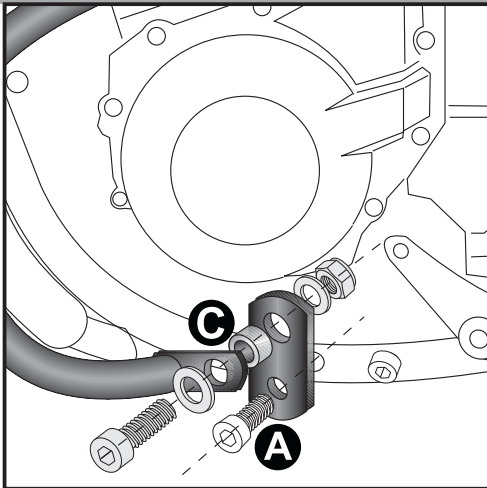

7

Montage des linken Motorschutzbügels:

- A** Montieren sie den kurzen Adapter mit der Originalschraube an der vorderen Verschraubung des Schalthebels.
- C** Den Motorschutzbügel mit der Inbusschraube M10 x 30, U-Scheiben  $\varnothing 10,5$  und selbstsichernder Mutter M10 befestigen. Zwischen Bügellasche und Adapter die Distanz  $\varnothing 25 \times \varnothing 11 \times 7$  mm einfügen.

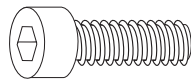

je 1x



2x

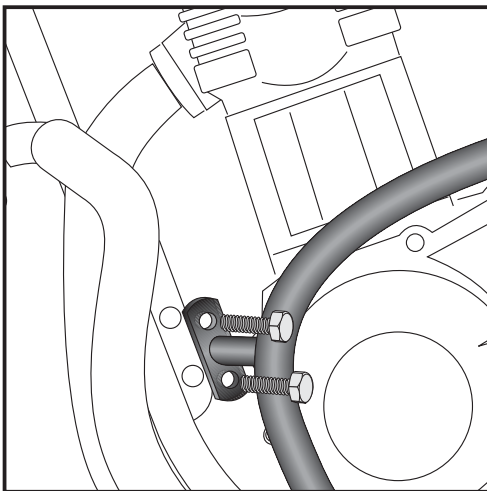
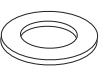

8

Montage des linken Motorschutzbügels:

Montieren sie den Motorschutzbügel links am Rahmenunterzug vor dem Motor mit den beiden Originalschrauben (SW 12).

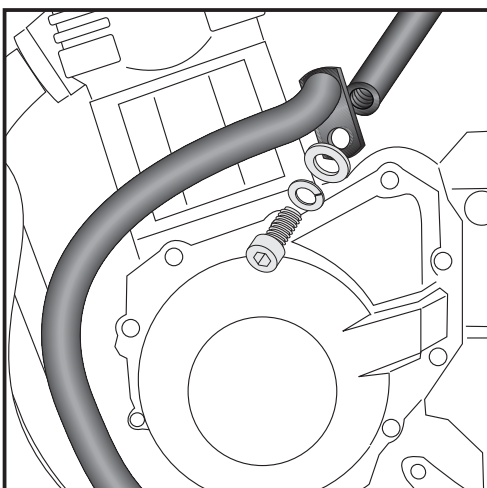

9

Zuletzt wird die Versteifungsstrebe mit dem Motorschutzbügel auf der linken Seite mit der Inbusschraube M8 x 16, der U-Scheibe  $\varnothing 8,4$  und dem Sprengring  $\varnothing 8,4$  verbunden.

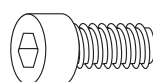

je 1x



Engine guard  
Suzuki GSF 650 Bandit  
from year of manufacture 2007

Item-No.  
501.325 00 01 black

Side cases  
Top cases  
luggage frames  
Lock it system  
Softbags  
Aluminium luggage  
Leather luggage  
Protection bars  
Center stands  
Chopper parts  
Quad parts  
Accessories



## Assembling instructions

The kit includes the following parts:

| Quant | item no.  | description  |
|-------|-----------|--|
| 1     | 703.507HB | engine guard left                                      |
| 1     | 703.508HB | engine guard right                                     |
| 1     | 703.509HB | bracing bow  |
| 1     | 703.274   | adapter, little (left)                                 |
| 1     | 150.860   | allen screw<br>M10 x 30                                |
| 1     | 151.110   | allen screw<br>M10 x 55 x 1,25                         |
| 1     | 150.841   | allen screw<br>M10 x 1,25 x 220                        |
| 2     | 150.780   | allen screw<br>M8 x 16                                 |
| 5     | 150.811   | washer $\varnothing 10,5$                              |
| 2     | 150.810   | washer $\varnothing 8,4$                               |
| 2     | 150.805   | lock ring $\varnothing 8,4$                            |
| 1     | 151.030   | spacer $\varnothing 25 \times \varnothing 11 \times 7$ |
| 1     | 151.050   | self-lock nut M 10                                     |
| 1     | 151.051   | self-lock nut M 10 x 1,25                              |

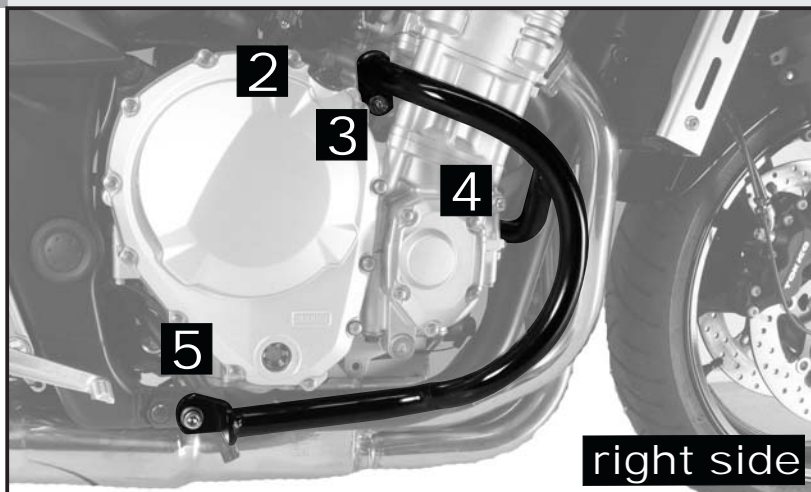

right side

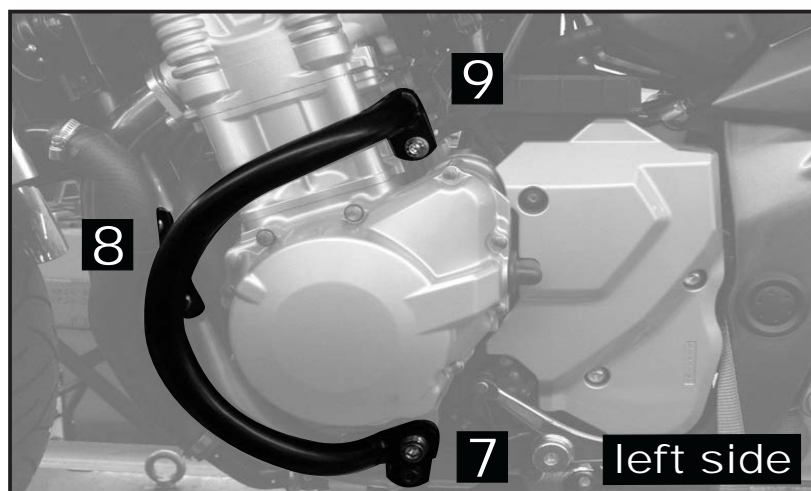

left side

**Control all screw connections after the assembling for tightness!**

**Please notice our enclosed service information.**

**All screws, bolts and nuts should be checked after driving the first 50 km to ensure that all are tightened to the proper torque.**

**Medium strength liquid thread-locker (i.e., „Locktite“) should be used to secure all screws, bolts, and nuts.**

Also available:

Side carrier 650.3512 00 01 black, „Lock it System“ (removable)

Rear rack 650.3512 01 01 black



**Hepco & Becker GmbH**  
An der Steinmauer 6  
D-66955 Pirmasens  
Germany

Tel.: +49 6331 - 1453 - 100  
Fax: +49 6331 - 1453 - 120  
eMail: [vertrieb@hepco-becker.de](mailto:vertrieb@hepco-becker.de)  
[www.hepco-becker.de](http://www.hepco-becker.de)



Engine guard  
Suzuki GSF 650 Bandit  
from year of manufacture 2007

Item-No.  
501.325 00 01 black

Side cases  
Top cases  
luggage frames  
Lock it system  
Softbags  
Aluminium luggage  
Leather luggage  
Protection bars  
Center stands  
Chopper parts  
Quad parts  
Accessories



## Assembling instructions

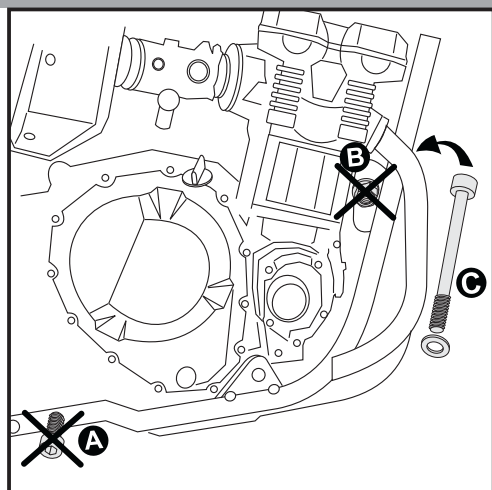

### 1 right side

Preparing:  
Unmount the screw, marked **A** in the picture.  
Unmount the nut at the frame in front of the engine. **B**  
Replace the original screw with allen screw M10x1,25x220 **C**  
and washer  $\varnothing 10,5$ .  
Push it through from left to right side.

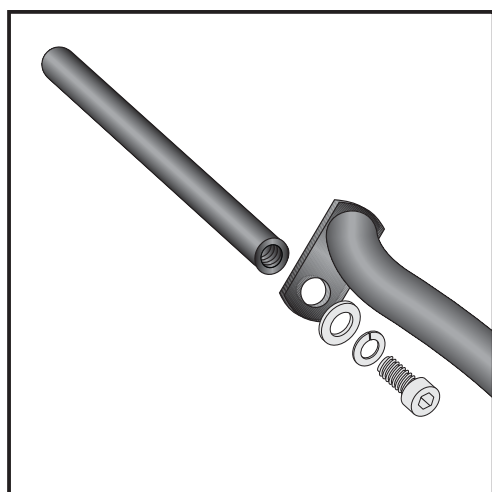
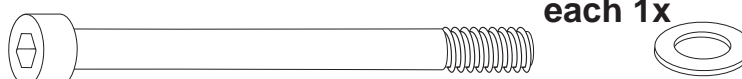

### 2

Fastening of the bracing bow:  
Mount the bracing bow at the crash bar right with allen screw M8 x 16,  
washer  $\varnothing 8,4$  and the lock ring  $\varnothing 8,4$ .

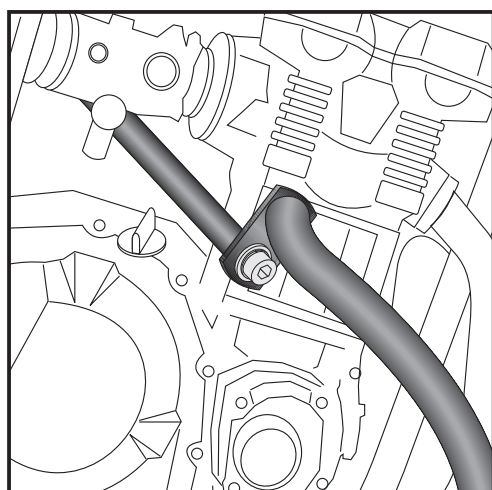

### 3

Move the bracing bow to the correct position behind the engine.

Engine guard  
Suzuki GSF 650 Bandit  
from year of manufacture 2007

Item-No.  
501.325 00 01 black

Side cases  
Top cases  
luggage frames  
Lock it system  
Softbags  
Aluminium luggage  
Leather luggage  
Protection bars  
Center stands  
Chopper parts  
Quad parts  
Accessories



## Assembling instructions

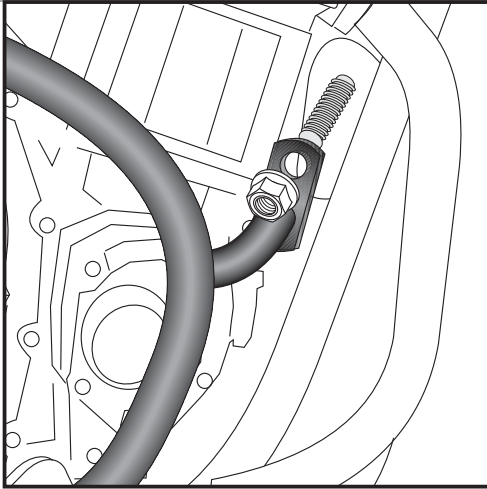

### 4 right side

Fastening of the crash bar right:

Fix crash bar at the end of the screw mounted in step 1.  
Use original nut. Hold the screw at the left side.

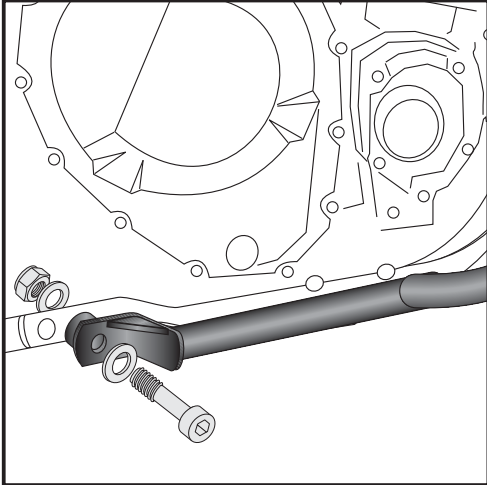

### 5

Fastening of the crash bar right:

Mount the big adapter with allen screw M10 x 55 x 1,25, washers  $\varnothing 10,5$  and self-lock nut M10 x 1,25. Notice: nut with fine thread

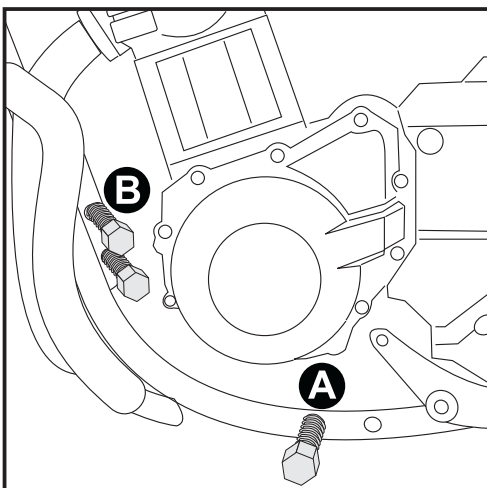

### 6 left side

Preparing:

Unmount the screw, marked **A** in the picture.

Unmount the screws, marked **B** in the picture (at the frame in front of the engine.)

The screws will be used again.

Engine guard  
Suzuki GSF 650 Bandit  
from year of manufacture 2007

Item-No.  
501.325 00 01 black

Side cases  
Top cases  
luggage frames  
Lock it system  
Softbags  
Aluminium luggage  
Leather luggage  
Protection bars  
Center stands  
Chopper parts  
Quad parts  
Accessories



## Assembling instructions

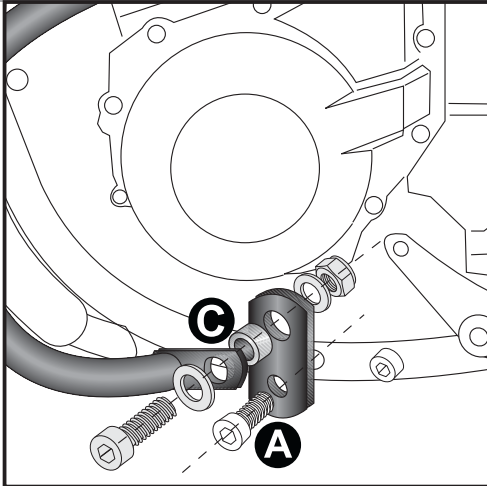

7

Fastening of the crash bar left:

- A** Mount the little adapter with original screw.
- C** Fix the crash bar with allen screw M10 x 30, washer  $\varnothing 10,5$  and self-lock nut M10.  
Sandwich spacer  $\varnothing 25 \times \varnothing 11 \times 7$  mm as shown in the picture.

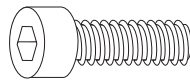

each 1x



2x

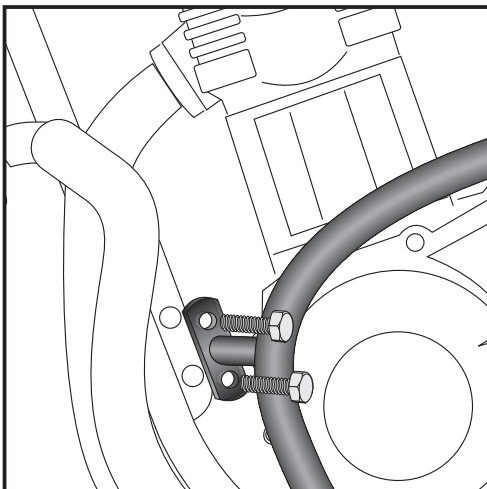

8

Fastening of the crash bar left front:

Fix the crash bar left in the free threaded holes with the original screws.

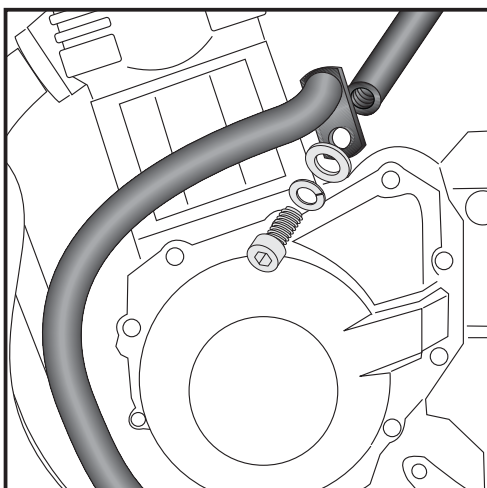

9

Fastening of the crash bar left:

Fix the bracing bow with the crash bar with allen screw M8 x 16, washer  $\varnothing 8,4$  and lock ring  $\varnothing 8,4$ .

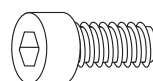

each 1x

