

Motorschutzbügel

SUZUKI GSR 750

Artikel-Nr.:
501.3526 00 01 schwarz

Seitenkoffer
Topcases
Gepäckträger
Lock it System
Softbags
Aluminiumkoffer
Lederkoffer
Schutzbügel
Hauptständer
Chopper-Parts
Accessoires



Montage

Der Bausatz umfaßt die folgenden Teile:

Stück	Bestellnr.	Bezeichnung
1	700007707	Motorschutzbügel links
1	700007708	Motorschutzbügel rechts
1	151.044	Inbusschraube M10x1,25x80
2	151.163	Inbusschraube M10x1,25x70
1	150.787	Inbusschraube M8x45
4	150.810	U-Scheibe ø8,4
3	150.811	U-Scheibe ø10,5
1	151.347	Stahldistanze Ø20xØ11x22mm
1	151.345	Stahldistanze Ø20x11x13mm
1	151.346	Stahldistanze Ø20xØ11x20mm
1	150.800	selbstsichernde Mutter M8
2	151.059	Stiftschraube M6 x 10mm

Tipp:
Schrauben sie alle Teile an und lassen sie die zugänglichen Schrauben etwas locker. Nachdem alles montiert ist, werden alle Schrauben auf das entsprechende Anzugsmoment angezogen. Dadurch wird sichergestellt, dass das Produkt spannungsfrei angebaut ist. Damit ist eine lange Lebensdauer sichergestellt !

Achtung ! Immer nur eine Seite nach der anderen montieren, ansonsten kann sich der Motor absenken.



Motorschutzbügel

SUZUKI GSR 750

Artikel-Nr.:
501.3526 00 01 schwarz

- Seitenkoffer
- Topcases
- Gepäckträger
- Lock it System
- Softbags
- Aluminiumkoffer
- Lederkoffer
- Schutzbügel
- Hauptständer
- Chopper-Parts
- Accessoires



Montage

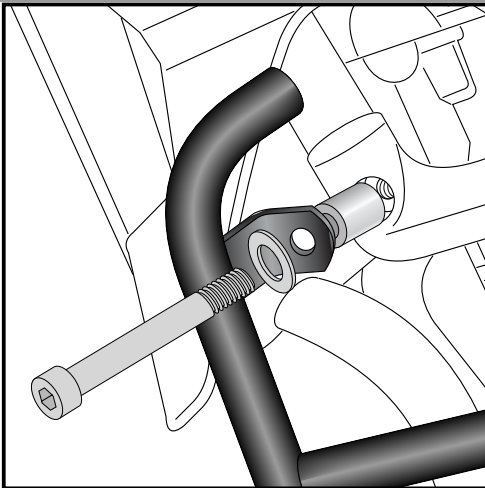

1

Befestigung des Motorschutzbügels links vorne:
Mit der Inbusschraube M10x1,25x80 und U-Scheibe $\varnothing 10,5$ an der Motorverschraubung.
Zwischen Motorschutzbügel und Rahmenteil die Stahldistanz $\varnothing 20 \times \varnothing 11 \times 22 \text{mm}$ einfügen.

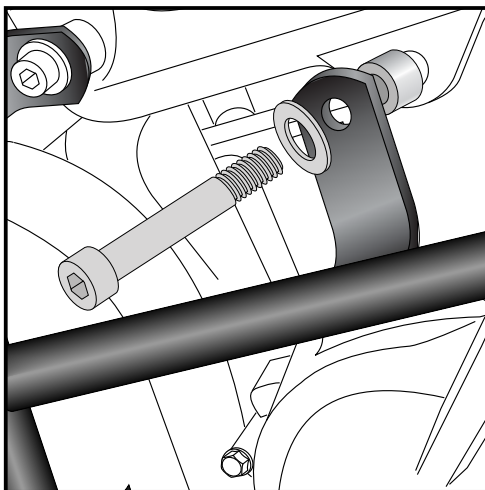
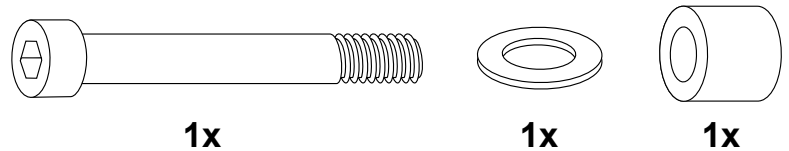

2

Befestigung des Motorschutzbügels links hinten:
Mit der Inbusschraube M10x1,25x70 und U-Scheibe $\varnothing 10,5$ an der Motorverschraubung.
Zwischen MSB und Rahmenteil die Stahldistanze $\varnothing 20 \times \varnothing 11 \times 13 \text{mm}$ fügen.

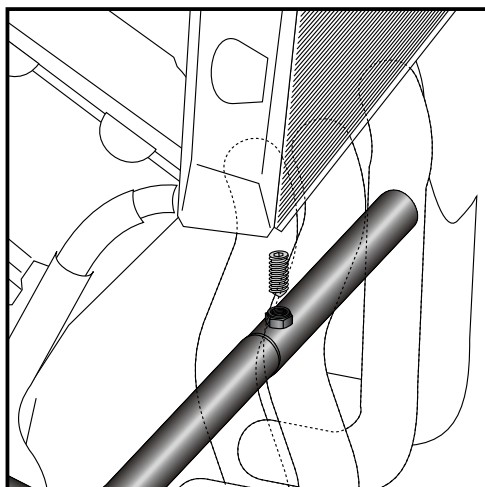
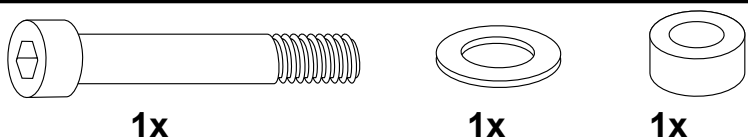

3

Nun den rechten Motorschutzbügel mit dem linken Bügel zusammenschieben.
Vorne hinter dem Krümmer, und hinten hinter den Zylindern.
Zum Ende der Montage werden die Verbindungsstellen mit der Stiftschraube M6x10 gesichert.

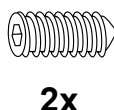

Motorschutzbügel

SUZUKI GSR 750

Artikel-Nr.:
501.3526 00 01 schwarz

Seitenkoffer
Topcases
Gepäckträger
Lock it System
Softbags
Aluminiumkoffer
Lederkoffer
Schutzbügel
Hauptständer
Chopper-Parts
Accessoires



Montage

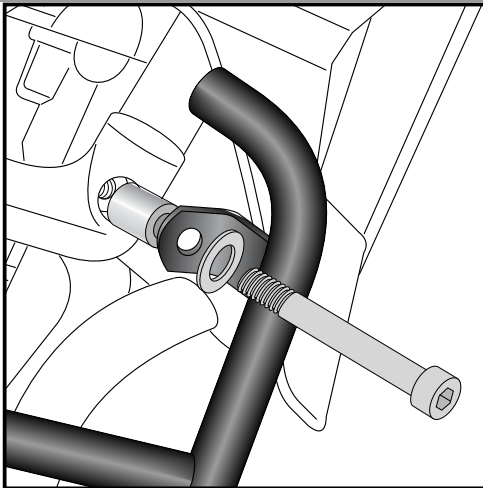

4

Befestigung des Motorschutzbügels rechts oben:
Mit der Inbusschraube M10x1,25x70 und U-Scheibe $\varnothing 10,5$ an der Motorverschraubung.
Zwischen MSB und Rahmenteil die Stahldistanz $\varnothing 20 \times \varnothing 11 \times 20 \text{mm}$ fügen.

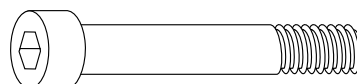

1x

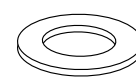

1x



1x

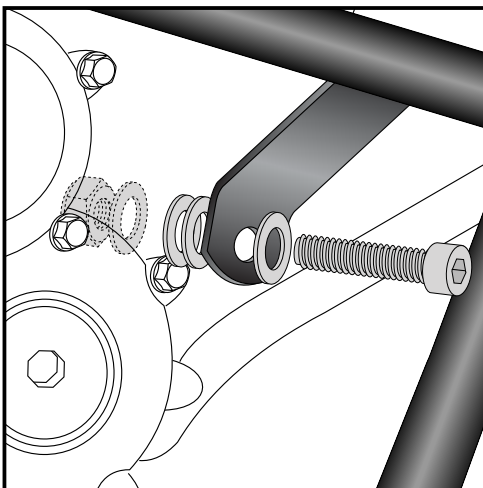

5

Befestigung des Motorschutzbügels rechts unten:
Mit der Inbusschraube M8x45 sowie U-Scheibe $\varnothing 8,4$ an der freien Bohrung am Motor.
Zwischen der Lasche des Motorschutzbügel und der Bohrung zwei U-Scheiben $\varnothing 8,4$ fügen.
Mit der selbstsichernden Mutter M8 und U-Scheibe $\varnothing 8,4$ verschrauben.

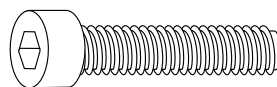

1x



4x

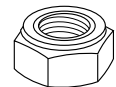

1x

Anzugsmomente des Motorradherstellers beachten!
Nach der Montage alle Verschraubungen auf festen Sitz kontrollieren!
Bitte beachten Sie unsere beigefügten Serviceinformationen.

Als weiteres Zubehör lieferbar:
Seitenträger Lock it (kombinierbar)
Alurack
Sportrack
C-Bow Halter für Softtaschen

Art.-Nr.: 650.3526 00 01
Art.-Nr.: 650.3526 01 01
Art.-Nr.: 670.3526
Art.-Nr.: 630.3526



Hepco & Becker GmbH
An der Steinmauer 6

D-66955 Pirmasens

Tel.: 06331 - 1453 - 100
Fax: 06331 - 1453 - 120
eMail: vertrieb@hepco-becker.de
www.hepco-becker.de

Engine guard

SUZUKI GSR 750

Item - No.:
501.3526 00 01 black

Side cases

Top cases

luggage frames

Lock it system

Softbags

Aluminium luggage

Leather luggage

Protection bars

Center stands

Chopper parts

Accessories



**HEPCO &
BECKER**

Assembling instructions

The kit includes the following parts:

Quant	item no.	description
1	700007707	engine guard left
1	700007708	engine guard rechts
1	151.044	allen screw M10x1,25x80
2	151.163	allen screw M10x1,25x70
1	150.787	allen screw M8x45
4	150.810	washer ø8,4
3	150.811	washer ø10,5
1	151.347	steel spacer Ø20xØ11x22mm
1	151.345	steel spacer Ø20x11x13mm
1	151.346	steel spacer Ø20xØ11x20mm
1	150.800	self-nock nut M8
2	151.059	grub screw M6 x 10mm

Tip:

Fit all parts and screw on not too strong.
After mounting all parts, the screws should be tightened to the torque specified.
This guarantees, that the kit is mounted without tension.

**NOTICE ! Do the mounting side by side.
Otherwise the engine block can change position.**



Engine guard

SUZUKI GSR 750

Item - No.:
501.3526 00 01 black

- Side cases
- Top cases
- luggage frames
- Lock it system
- Softbags
- Aluminium luggage
- Leather luggage
- Protection bars
- Center stands
- Chopper parts
- Accessories



Assembling instructions

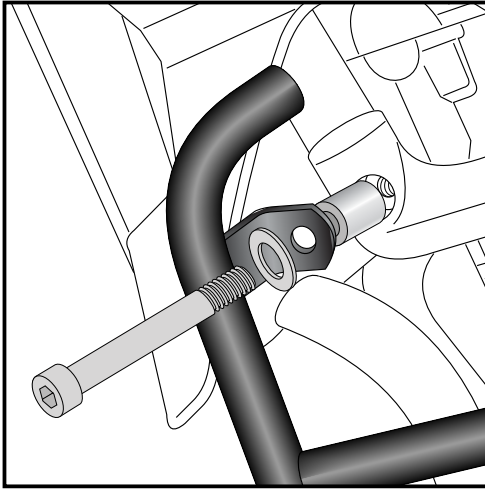

1

Fastening of the engine guard left top:

with allen screws M10x1,25x80 and washer $\varnothing 10,5$ at the engine bolting. Sandwich steel spacer $\varnothing 20 \times \varnothing 11 \times 22 \text{mm}$ between engine guard and frame.

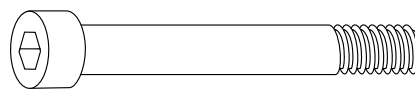

1x

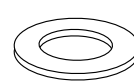

1x



1x

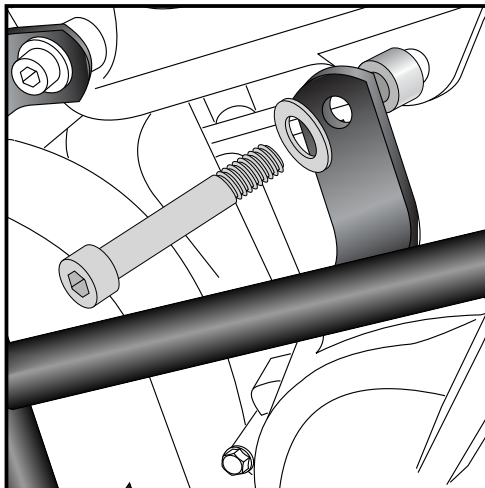

2

Fastening of the engine guard left top:

with allen screws M10x1,25x70 and washer $\varnothing 10,5$ at the engine bolting. Sandwich steel spacer $\varnothing 20 \times \varnothing 11 \times 13 \text{mm}$ between engine guard and frame.

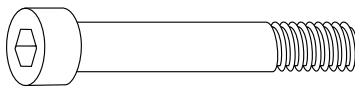

1x

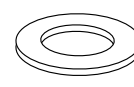

1x

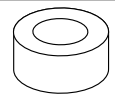

1x

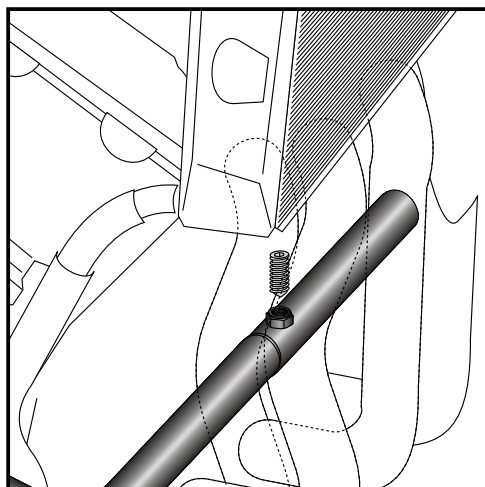

3

Stick the right crash bar into the left one and secure the parts with the grub screws M6x10.

Front: behind the exhaust tubes
Rear: behind the cylinders

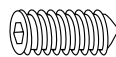

2x

Engine guard

SUZUKI GSR 750

Item - No.:
501.3526 00 01 black

Side cases
Top cases
luggage frames
Lock it system
Softbags
Aluminium luggage
Leather luggage
Protection bars
Center stands
Chopper parts
Accessories



Assembling instructions

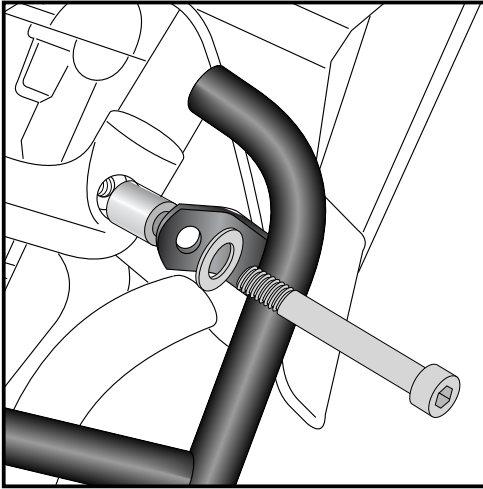

4

Fastening of the engine guard right top:
with allen screws M10x1,25x70 and washer $\varnothing 10,5$ at the engine bolting. Sandwich steel spacer $\varnothing 20 \times \varnothing 11 \times 20$ mm between engine guard and frame.

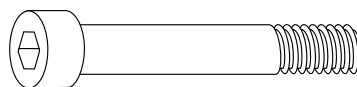

1x

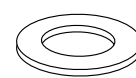

1x

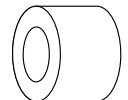

1x

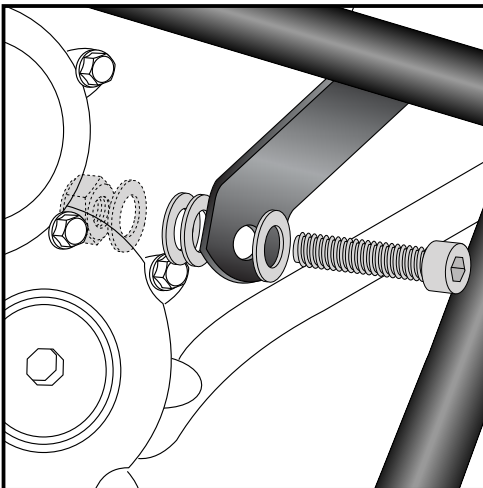

5

Fastening of the engine guard right bottom:
with allen screws M8x45 and washer $\varnothing 8,4$ at the free engine boring. Sandwich two washers $\varnothing 8,4$ between engine guard and engine block. Secure the screw with washer $\varnothing 8,4$ and self lock nut M8.

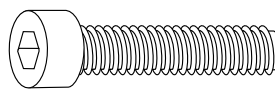

1x



4x

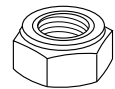

1x

Control all screw connections after the assembling for tightness!
Please notice our enclosed service information.

Also available:
Side carrier Lock it (can be combined)
Alurack
Sportrack
C-Bow Holder for softbags

Item-No. 650.3526 00 01
Item-No. 650.3526 01 01
Item-No. 670.3526
Item-No. 630.3526



Hepco & Becker GmbH
An der Steinmauer 6
D-66955 Pirmasens
Germany

Tel.: +49 6331 - 1453 - 100
Fax: +49 6331 - 1453 - 120
eMail: vertrieb@hepco-becker.de
www.hepco-becker.de