

# Motorschutzbügel SUZUKI C 1800 R Intruder

Artikel Nr.:  
501.3516 00 02 chrom

## Montage

Der Bausatz umfaßt die folgenden Teile:

Stück	Bestellnr.	Bezeichnung
1	703.516HB	Schutz- und Zierbügel links
1	703.517HB	Schutz- und Zierbügel rechts
2	150.843	Sechskantschrauben M 8 x 40
2	150.805	Sprengring ø8,4mm
2	150.810	U-Scheiben ø8,4mm

### HINWEIS

Nicht kompatibel mit der  
Original-Windschutzscheibe

Seitenkoffer  
Topcases  
Gepäckträger  
Lock it System  
Softbags  
Aluminiumkoffer  
Lederkoffer  
Schutzbügel  
Hauptständer  
Chopper-Parts  
Quad-Parts  
Accessoires



rechte Seite



linke Seite

**Nach der Montage alle Verschraubungen auf festen Sitz kontrollieren!**

**Bitte beachten Sie unsere beigefügten Serviceinformationen.**

**Weiteres Zubehör für Suzuki Intruder C 1800 R:**

Kofferträger	Art.-Nr. 650.3516 00 02
Gepäckbrücke	Art.-Nr. 650.3516 01 02
Packtaschenhalter	Art.-Nr. 625.3516
Sissybar mit und ohne Gepäckbrücke	Art.-Nr. 611.3516/600.3516
Twinlight-Set	Art.-Nr. 400.3516
Solorack	Art.-Nr. 611.3517
Fender Guard	Art.-Nr. 410.3516
Leder-Tankcover mit Tasche	Art.-Nr. 622.3516.250



**Hepco & Becker GmbH**  
**An der Steinmauer 6**

**D-66955 Pirmasens**

**Tel.: 06331 - 1453 - 100**

**Fax: 06331 - 1453 - 120**

**eMail: [vertrieb@hepco-becker.de](mailto:vertrieb@hepco-becker.de)**

**[www.hepco-becker.de](http://www.hepco-becker.de)**



## Montage

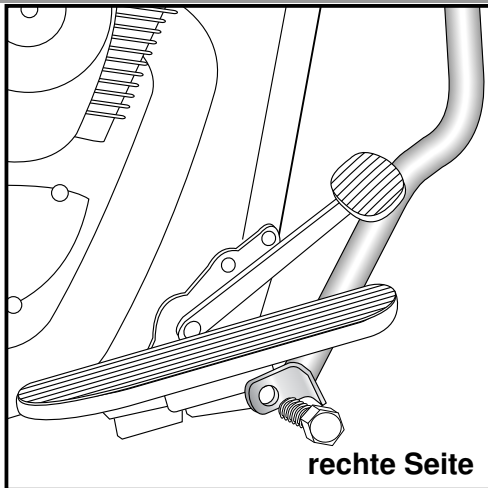

1

### Unbedingt mit der rechten Seite beginnen !

Befestigung des Schutzbügels rechts unten:  
An der vorderen Verschraubung der Fußrastenausleger.  
Zur Befestigung die Originalschraube verwenden.

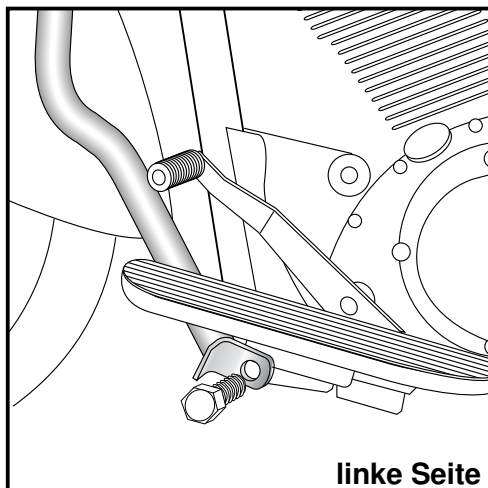

2

Befestigung des Schutzbügels links unten:  
An der vorderen Verschraubung der Fußrastenausleger.  
Zur Befestigung die Originalschraube verwenden.

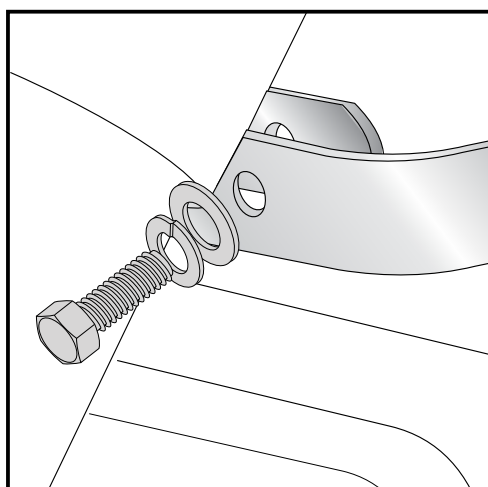

3

Befestigung des Schutzbügels vorne oben:  
An den beiden oberen Befestigungspunkten des Kühlers.  
Die Originalschrauben entfallen.  
Da rechts zuerst montiert, liegt die rechte Seite des Schutzbügels  
direkt über den Befestigungspunkten des Kühlers an.  
Die linke Hälfte des Bügels überlappt.  
Zur Befestigung der Bügelteile die Sechskantschrauben M8 x 40  
mit Sprengling und U-Scheiben  $\varnothing 8,4$  verwenden.

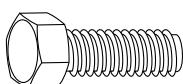

je 2x



Engine guard  
SUZUKI C 1800 R Intruder

Item-No.  
501.3516 00 02 chrome

**Assembling instructions**

- Side cases
- Top cases
- luggage frames
- Lock it system
- Softbags
- Aluminium luggage
- Leather luggage
- Protection bars
- Center stands
- Chopper parts
- Quad parts
- Accessories



The kit includes the following parts:

Quant	item no.	description
1	703.516HB	crash bar left
1	703.517HB	crash bar right
2	150.843	Hexagon bolt M 8 x 40
2	150.805	lock ring ø8,4mm
2	150.810	washer ø8,4mm



right side

**NOTE**

Not compatible with  
the original windshield



left side

**Control all screw connections after the assembling for tightness!**

**Please notice our enclosed service information.**

**Also available for the Suzuki Intruder C 1800 R:**

Side carrier	Item.-No. 650.3516 00 02
Rear rack	Item.-No. 650.3516 01 02
Leather bag holder	Item.-No. 625.3516
Sissybar with/without rear rack	Item.-No. 611.3516/600.3516
Twinlight-Set	Item.-No. 400.3516
Solorack	Item.-No. 611.3517
Fender Guard	Item.-No. 410.3516
Leather-tankcover	Item.-No. 622.3516.250

**Hepco & Becker GmbH**  
An der Steinmauer 6  
D-66955 Pirmasens  
Germany

**Tel.: +49 6331 - 1453 - 100**

**Fax: +49 6331 - 1453 - 120**

**eMail: [vertrieb@hepco-becker.de](mailto:vertrieb@hepco-becker.de)**

**[www.hepco-becker.de](http://www.hepco-becker.de)**



Engine guard  
SUZUKI C 1800 R Intruder

Item-No.  
501.3516 00 02 chrome

- Side cases
- Top cases
- Luggage frames
- Lock it system
- Softbags
- Aluminium luggage
- Leather luggage
- Protection bars
- Center stands
- Chopper parts
- Quad parts
- Accessories



**Assembling instructions**

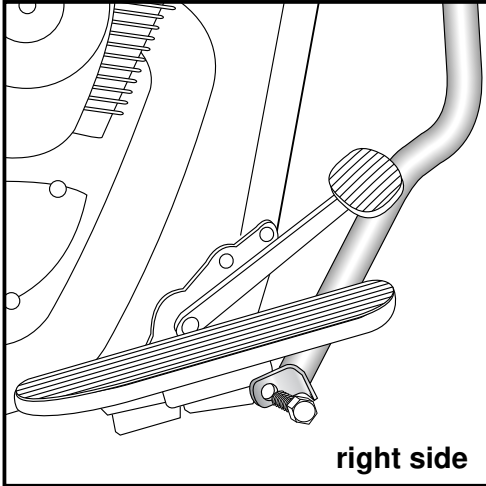

**1 Start with the right side !**

Fastening of the crash bar right bottom:  
At the front screw connection of the footrest bracket with original screw.

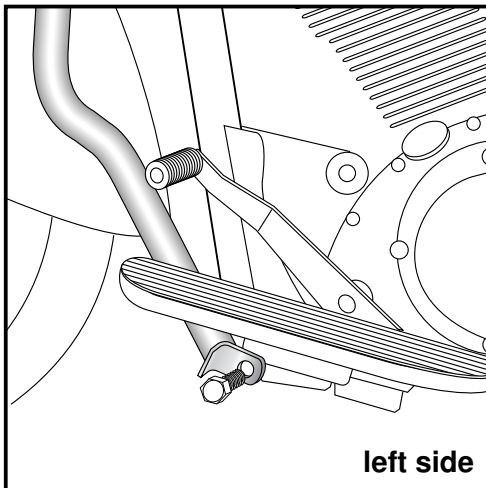

**2 Fastening of the crash bar left bottom:**

At the front screw connection of the footrest bracket with original screw

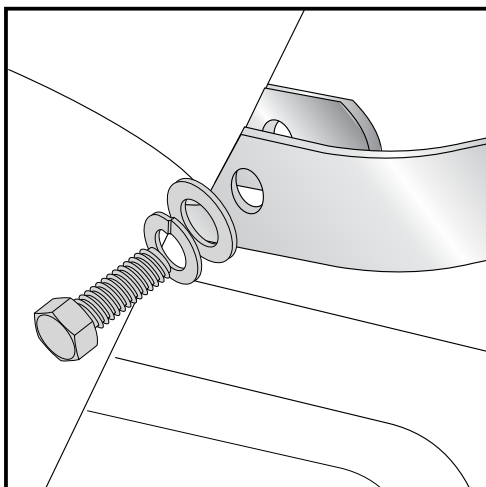

**3 Fastening of the crash bars front top:**

At the front screw connection of the cooler.  
Original screws are not needed any more.  
The left part of the crash bar should be in front of the right part.  
For fastening, use hexagon bolts M8 x 40 with lock ring and washer  $\varnothing 8,4$  .

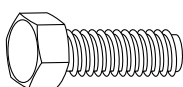

each 2x

