

Motorschutzbügel  
YAMAHA XJ 6 / Diversion

Artikel-Nr.:  
501.4530 00 01 schwarz

Seitenkoffer  
Topcases  
Gepäckträger  
Lock it System  
Softbags  
Aluminiumkoffer  
Lederkoffer  
Schutzbügel  
Hauptständer  
Chopper-Parts  
Quad-Parts  
Accessoires



## Montage

Der Bausatz umfaßt die folgenden Teile:

Stück	Bestellnr.	Bezeichnung
1	704.520HB	Motorschutzbügel, links
1	704.521HB	Motorschutzbügel, rechts
2	150.841	Sechskantschrauben M 8 x 30
2	150.810	U-Scheiben ø8,4
1	151.020	Stiftschraube M6
4	151.116	Alu-Distanzen ø18 x ø9 x 5 mm

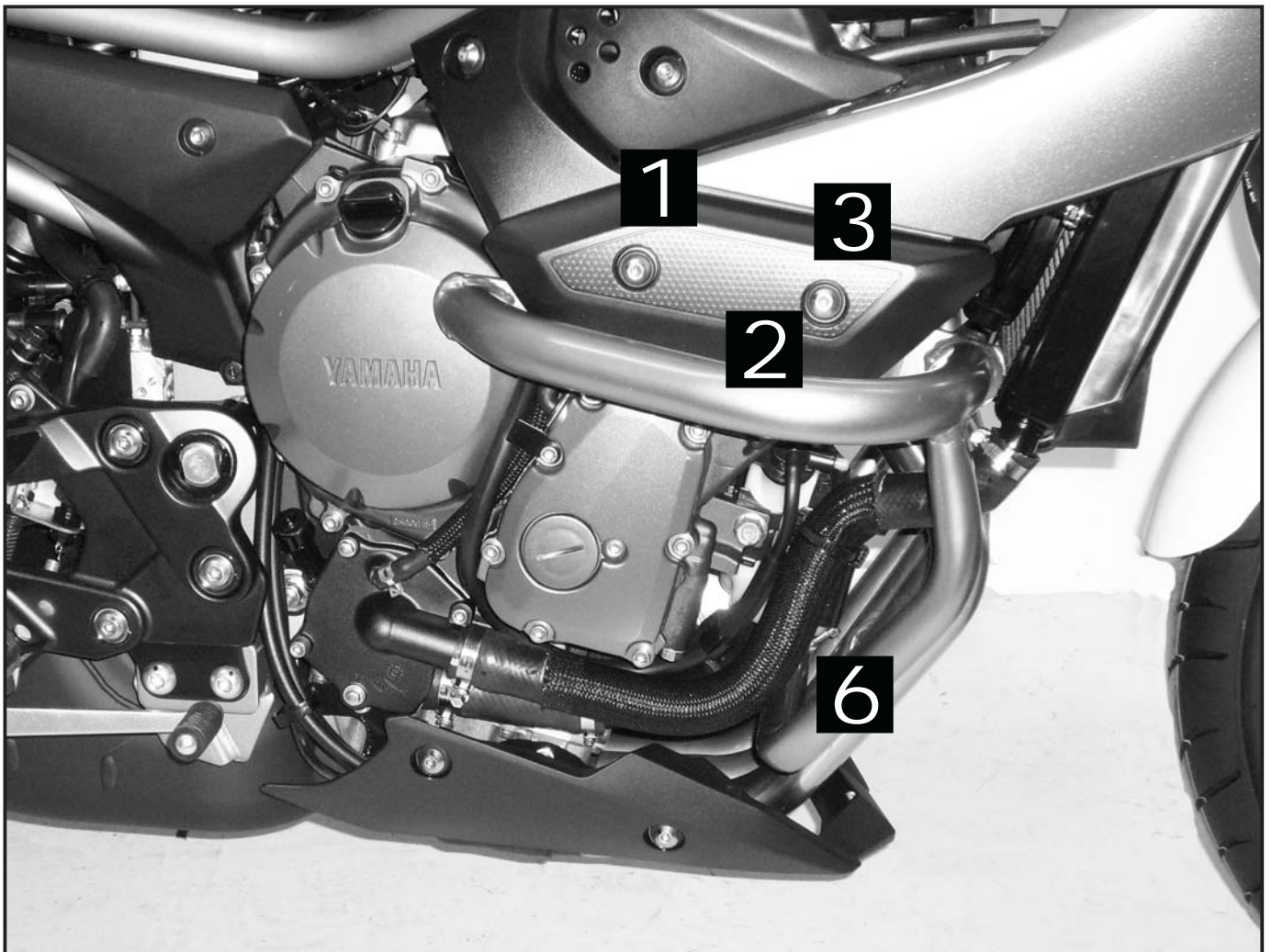

Motorschutzbügel  
YAMAHA XJ 6 / Diversion

Artikel-Nr.:  
501.4530 00 01 schwarz

Seitenkoffer  
Topcases  
Gepäckträger  
Lock it System  
Softbags  
Aluminiumkoffer  
Lederkoffer  
Schutzbügel  
Hauptständer  
Chopper-Parts  
Quad-Parts  
Accessoires



## Montage

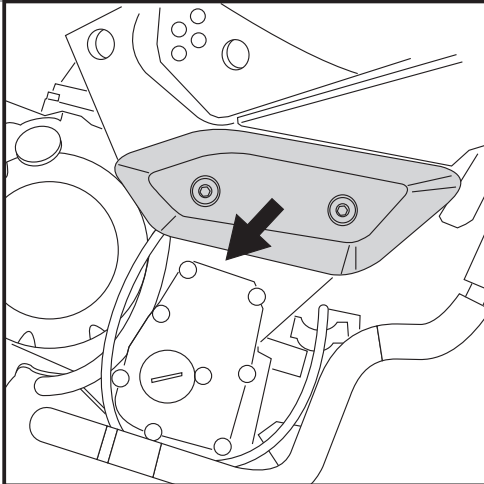

1

Vorbereitung:  
Seitenverkleidungen links und rechts demontieren.

**ACHTUNG !**  
Da zur Befestigung der Motorschutzbügel die Schrauben der Motoraufhängung herausgedreht werden müssen, erst die rechte Seite fertigstellen, bevor mit der linken Seite begonnen wird. Ansonsten kann sich der Motor absenken.

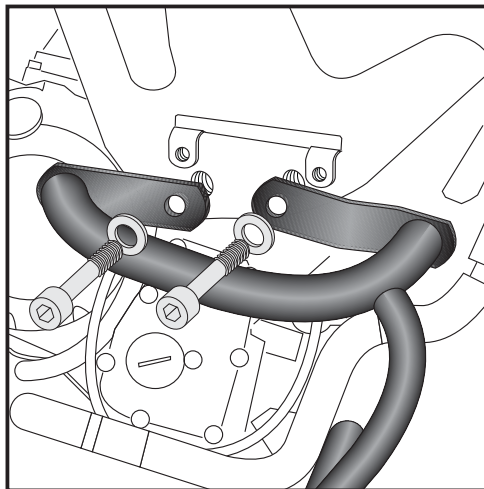

2

## Rechte Seite

Montage des rechten Motorschutzbügels:  
An den Befestigungen der Motoraufhängung mit den Originalschrauben.

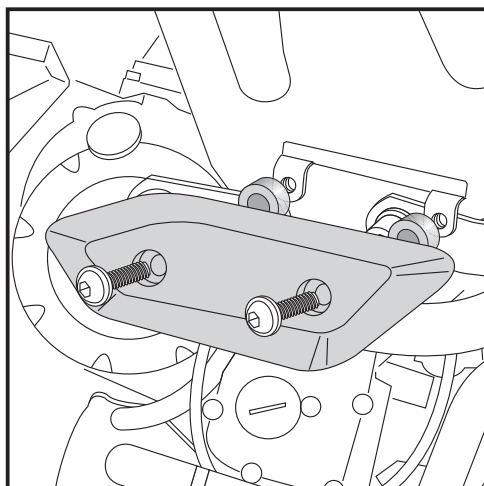

3

Montage der rechten Seitenverkleidung:  
Bei der Montage der Seitenverkleidung hinter die beiden Schrauben die Alu-Distanzen  $\varnothing 18 \times \varnothing 9 \times 5\text{mm}$  einfügen.





## Montage

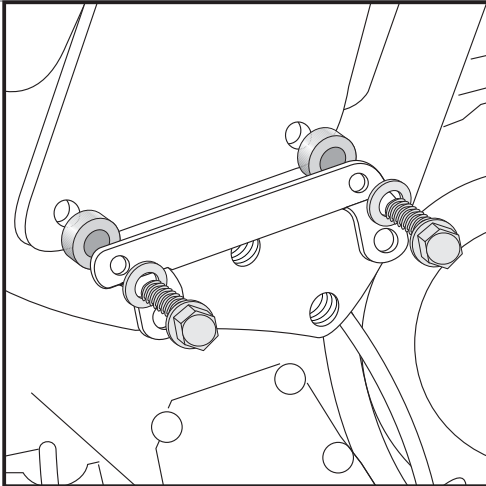

### 4 Linke Seite

Montage des linken Motorschutzbügels - Vorbereitung:

Das Halteblech für die Seitenverkleidung demontieren und die Aludistanzen  $\varnothing 18 \times \varnothing 9 \times 5$  mm zwischenfügen.

Zur Verschraubung des Halteblechs die Sechskantschrauben M8 x 30 mit U-Scheiben  $\varnothing 8,4$  verwenden.

Die Originalschrauben entfallen.

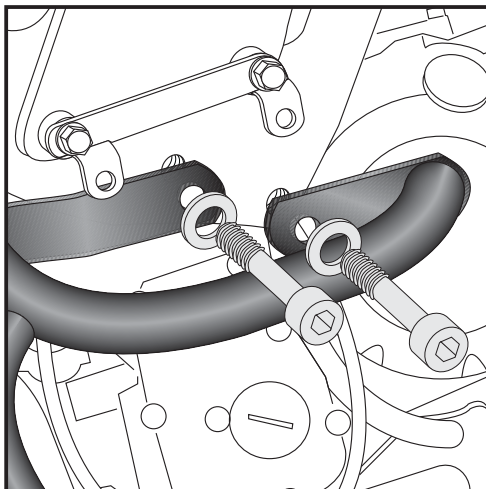
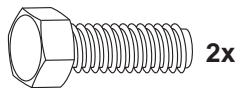

### 5 Montage des linken Motorschutzbügels:

An den Befestigungen der Motoraufhängung mit den Originalschrauben. Seitenverkleidung wieder montieren.

### 6 Die unteren Rohre der Motorschutzbügelteile verlaufen zwischen Motorblock und Krümmern. Sie werden zusammengesteckt und mit der Stiftschraube M6 gesichert.



**Anzugsmomente des Motorradherstellers beachten!**  
Nach der Montage alle Verschraubungen auf festen Sitz kontrollieren!  
Bitte beachten Sie unsere beigefügten Serviceinformationen.

Als weiteres Zubehör lieferbar:

Kofferträger Lock it (abnehmbar)  
Gepäckbrücke Alurack

Art.-Nr.: 650.4530 00 01 schwarz  
Art.-Nr.: 650.4530 01 01 schwarz



Hepco & Becker GmbH  
An der Steinmauer 6

D-66955 Pirmasens

Tel.: +49 (0)6331 - 1453 - 100  
Fax: +49 (0)6331 - 1453 - 120  
eMail: [vertrieb@hepco-becker.de](mailto:vertrieb@hepco-becker.de)  
[www.hepco-becker.de](http://www.hepco-becker.de)

Engine guard  
YAMAHA XJ 6 / Diversion

Item - No.:  
501.4530 00 01 black

- Side cases
- Top cases
- luggage frames
- Lock it system
- Softbags
- Aluminium luggage
- Leather luggage
- Protection bars
- Center stands
- Chopper parts
- Quad parts
- Accessories



Assembling instructions

The kit includes the following parts:

Quant	item no.	description
1	704.520HB	Engine guard, left
1	704.521HB	Engine guard, right
2	150.841	Hexagon bolt M 8 x 30
2	150.810	washer ø8,4
1	151.020	Stud bolt M6
4	151.116	Spacer ø18 x ø9 x 5 mm

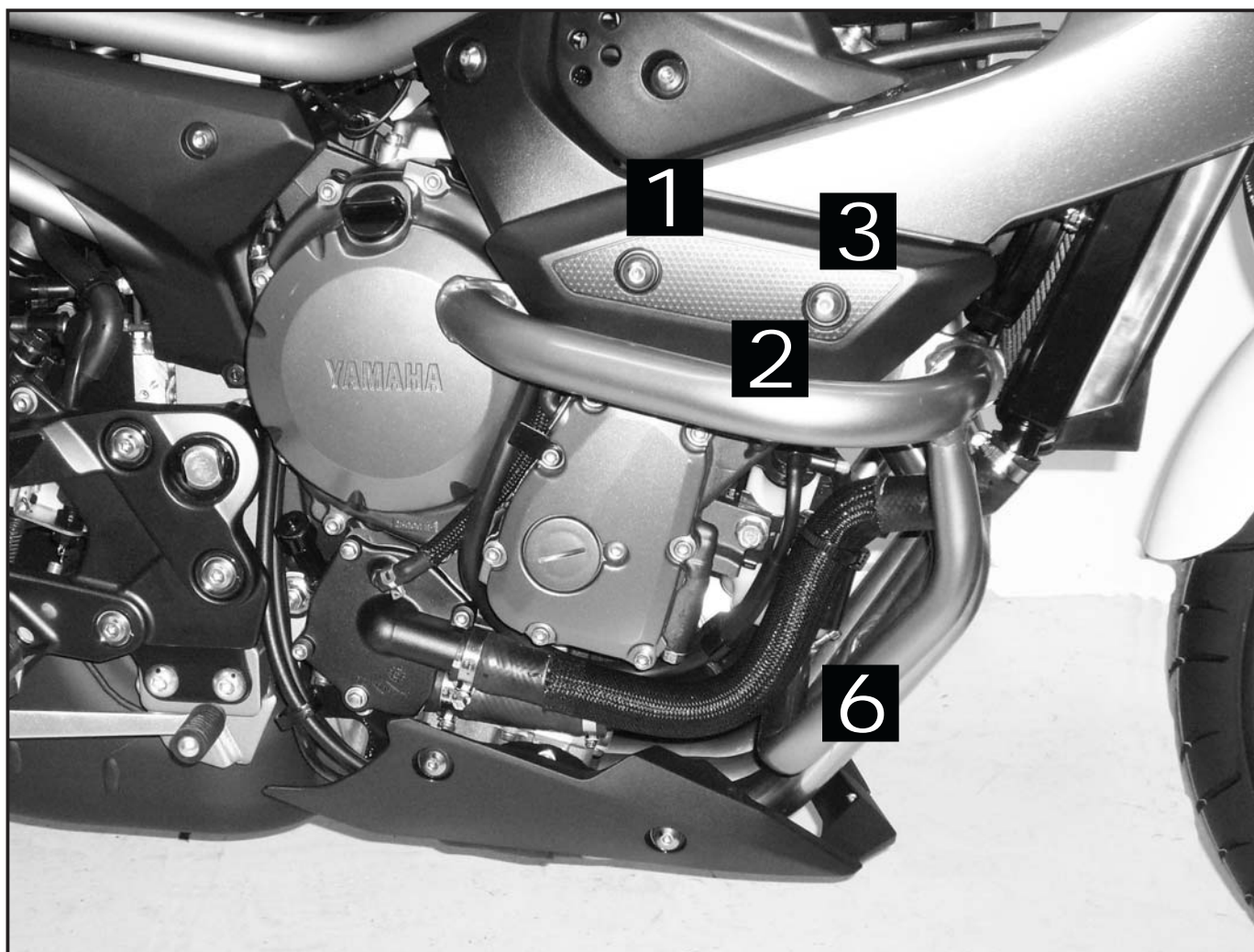



Engine guard  
YAMAHA XJ 6 / Diversion

Item - No.:  
501.4530 00 01 black

- Side cases
- Top cases
- Luggage frames
- Lock it system
- Softbags
- Aluminium luggage
- Leather luggage
- Protection bars
- Center stands
- Chopper parts
- Quad parts
- Accessories



Assembling instructions

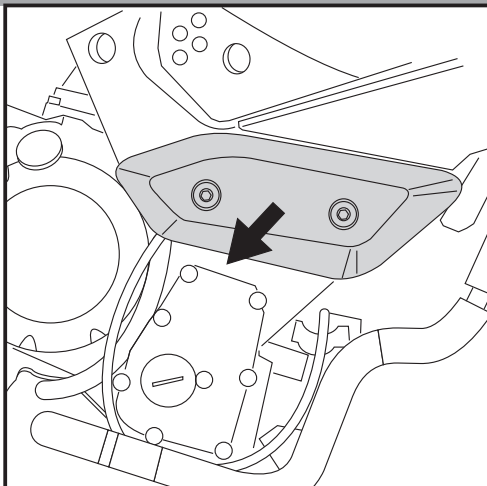

1

Preparing:  
Dismantle side covers left and right.

**NOTICE !**  
Because the engine suspension is used for mounting the engine guards it is necessary to do it side by side. Start with the right side, after finishing do the same with the left side.  
Do not unscrew the bolts of the engine suspension on both sides at the same time !

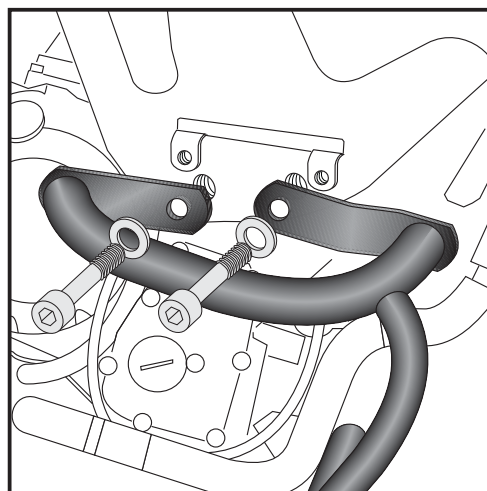

2

right side

Fastening of the right engine guard:  
At the engine suspension with the original screws.

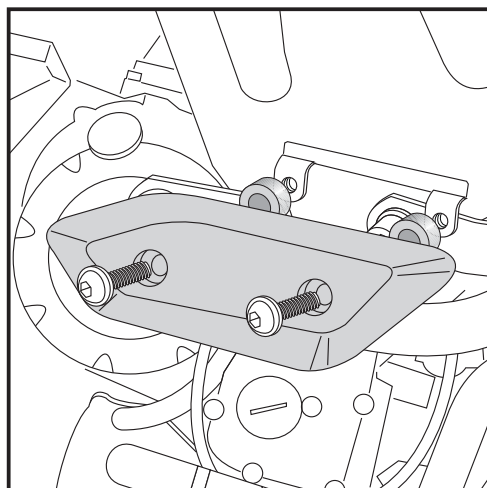

3

Fastening of the right side cover:  
Sandwich spacer  $\varnothing 18 \times \varnothing 9 \times 5\text{mm}$  behind the cover before mounting.



Engine guard  
YAMAHA XJ 6 / Diversion

Item - No.:  
501.4530 00 01 black

Side cases  
Top cases  
luggage frames  
Lock it system  
Softbags  
Aluminium luggage  
Leather luggage  
Protection bars  
Center stands  
Chopper parts  
Quad parts  
Accessories



Assembling instructions

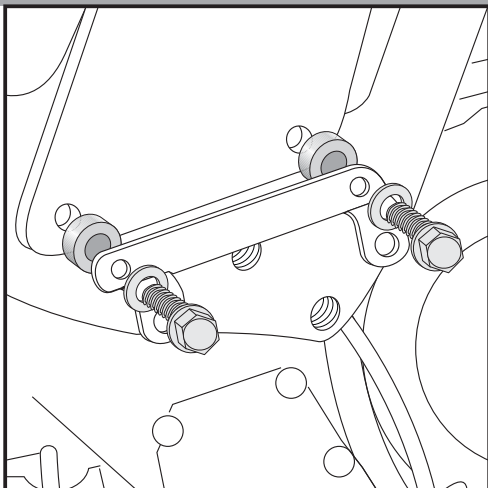

4 left side

Fastening of the left engine guard - preparing:  
Dismantle the bracket for the side cover and sandwich spacer  $\varnothing 18 \times \varnothing 9 \times 5$  mm.  
Fix it with hexagon bolts M8 x 30 and washers  $\varnothing 8,4$ .  
Original screws are obsolete.

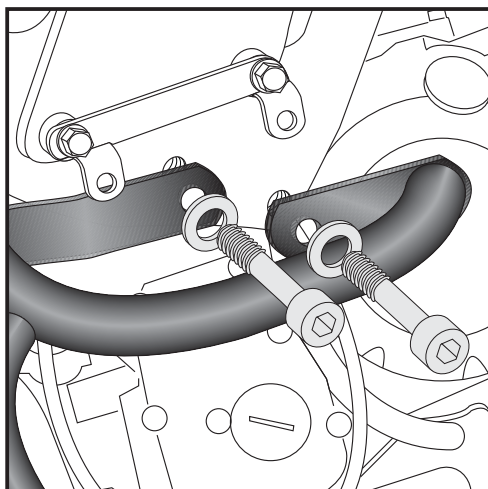
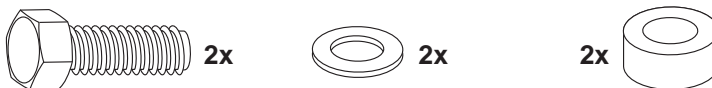

5 Fastening of the left engine guard:  
At the engine suspension with the original screws.  
Mount the side cover.

6 Both parts of the engine guards were connected in front of the engine and will be secured with a stud bolt M6.



Control all screw connections after the assembling for tightness!  
Please notice our enclosed service information.

Also available:

Side carrier Lock it (removable)  
Rear rack - Alurack

Item.-no.: 650.4530 00 01 black  
Item.-no.: 650.4530 01 01 black



Hepco & Becker GmbH  
An der Steinmauer 6

D-66955 Pirmasens

Tel.: +49 (0)6331 - 1453 - 100  
Fax: +49 (0)6331 - 1453 - 120  
eMail: [vertrieb@hepco-becker.de](mailto:vertrieb@hepco-becker.de)  
[www.hepco-becker.de](http://www.hepco-becker.de)