

Motorschutzbügel
YAMAHA XT 660 Z Ténére

Artikel-Nr.:
502.405 00 01 schwarz

Seitenkoffer
Topcases
Gepäckträger
Lock it System
Softbags
Aluminiumkoffer
Lederkoffer
Schutzbügel
Hauptständer
Chopper-Parts
Quad-Parts
Accessoires



Montage

Der Bausatz umfaßt die folgenden Teile:

Stück	Bestellnr.	Bezeichnung
1	704.517HB	Motorschutzbügel, links
1	704.518HB	Motorschutzbügel, rechts
1	704.519HB	Querstrebe
1	151.457	Sechskantschraube M10 x 100
1	151.184	Sechskantschraube M10 x 90
1	151.183	Sechskantschraube M10 x 75
2	150.782	Inbusschrauben M8 x 20
2	150.788	Inbusschraube M8 x 50
6	150.811	U-Scheiben ø10,5
6	150.810	U-Scheiben ø8,4
3	150.801	selbstsichernde Mutter M10
2	150.800	selbstsichernde Mutter M8



Abbildung mit Zubehör „Micro-Floater“

1104/14/15042014

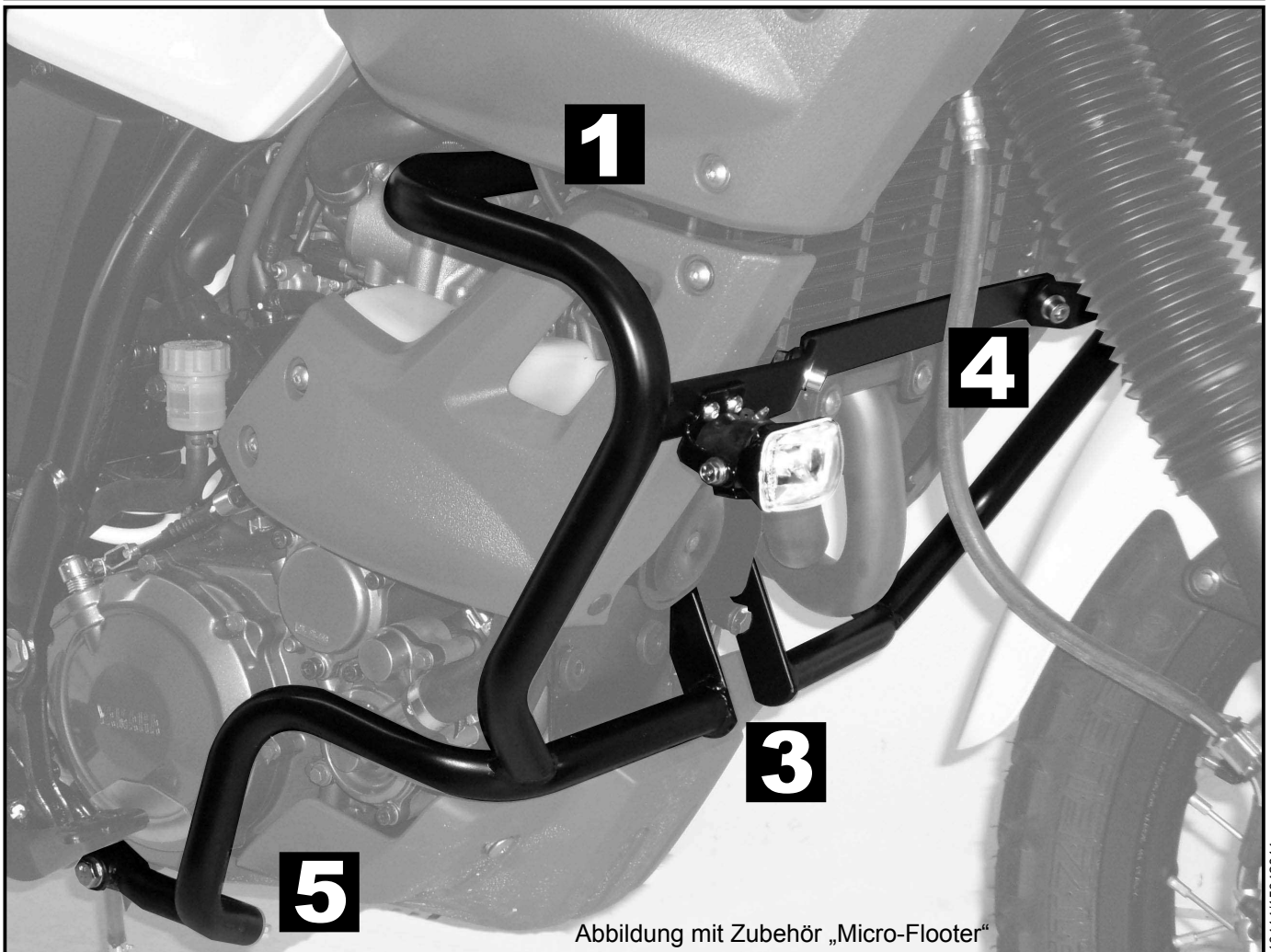

Montage

Vorbereitung:

Kunststoffverkleidung am Tank links und rechts demontieren.

Steuergerät unterhalb der Hupe abbauen.

Originalschraube der unteren Motoraufhängung herausschrauben, sie entfällt.

Originalschrauben der hinteren Befestigung des Kunststoff-Motorschutzes herausschrauben, sie entfallen.

Tipp:

Schrauben sie alle Teile an und lassen sie die zugänglichen Schrauben etwas locker. Nachdem alles montiert ist, werden alle Schrauben auf das entsprechende Anzugsmoment angezogen. Dadurch wird sichergestellt, dass das Produkt spannungsfrei angebaut ist. Damit ist eine lange Lebensdauer sichergestellt !

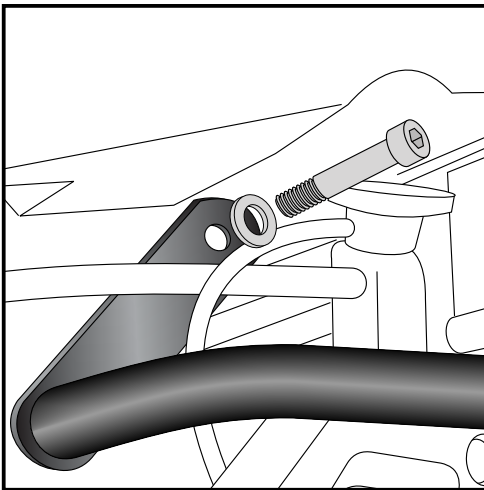

1

Montage des Motorschutzbügels rechts oben:

An der unteren Tankbefestigung - die lange Originalschraube entfällt. Stattdessen die Inbusschraube M8 x 50 + U-Scheibe $\varnothing 8,4$ verwenden.

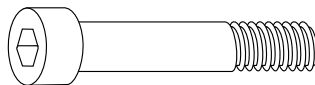

je 1x

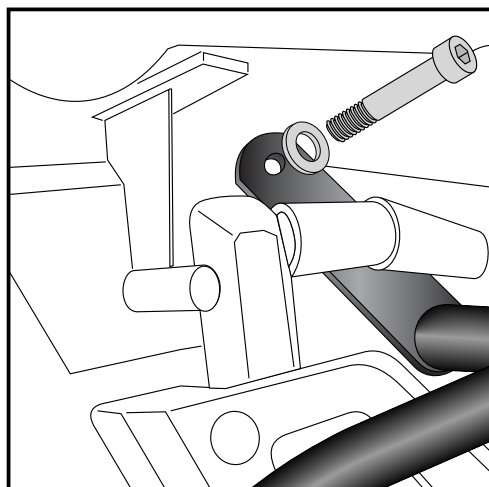
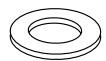

2

Montage des Motorschutzbügels links oben:

An der unteren Tankbefestigung - die lange Originalschraube entfällt. Stattdessen die Inbusschraube M8 x 50 + U-Scheibe $\varnothing 8,4$ verwenden.

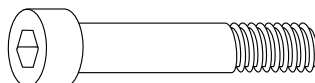

je 1x





Montage

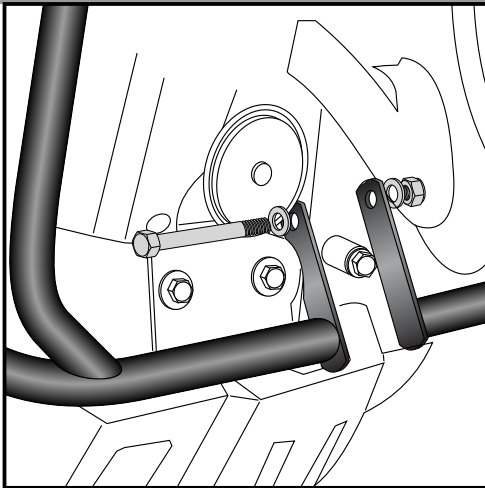

3

Montage des Motorschutzbügels mitte vorne:

In der Bohrung der zuvor demontierten Schraube der unteren Motoraufhängung.

Sechskantschraube M10 x 90 von rechts nach links einbauen !

Verschraubung mit U-Scheiben $\varnothing 10,5$ und selbstsichernder Mutter M10.

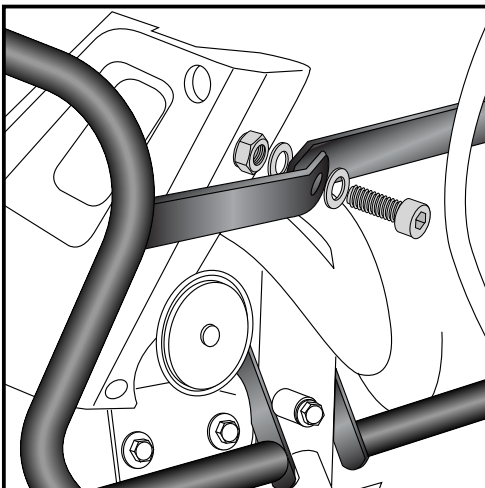
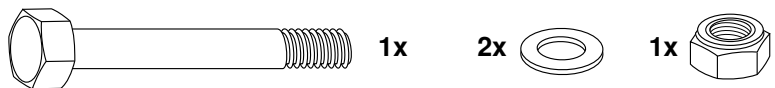

4

Montage des Querstrebe mitte vorne:

Zwischen den beiden Motorschutzbügeln unterhalb des Kühlers.

Verschraubung mit Inbusschrauben M8 x 20, U-Scheiben $\varnothing 8,4$ und selbstsichernden Muttern M8.

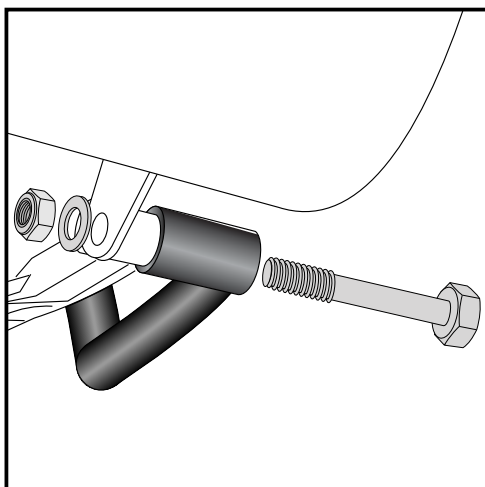

5

Montage des Motorschutzbügels rechts unten:

An der hinteren Befestigung des Motorschutzes mit der Sechskantschraube M10 x 100.

Schraube wird von außen nach innen montiert.

Verschraubung mit U-Scheiben $\varnothing 10,5$ und selbstsichernder Mutter M10.

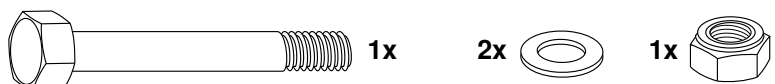

Motorschutzbügel
YAMAHA XT 660 Z Ténééré

Artikel-Nr.:
502.405 00 01 schwarz

Seitenkoffer
Topcases
Gepäckträger
Lock it System
Softbags
Aluminiumkoffer
Lederkoffer
Schutzbügel
Hauptständer
Chopper-Parts
Quad-Parts
Accessoires



Montage

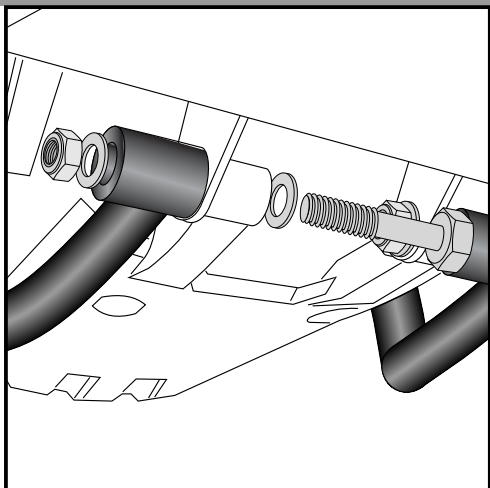

6

Montage des Motorschutzbügels links unten:
An der hinteren Befestigung des Motorschutzes mit der Sechskantschraube M10 x 75.
Schraube wird von innen nach außen montiert.
Verschraubung mit U-Scheiben $\varnothing 10,5$ und selbstsichernder Mutter M10.

Steuergerät und Verkleidung wieder montieren.



Anzugsmomente des Motorradherstellers beachten!
Nach der Montage alle Verschraubungen auf festen Sitz kontrollieren!
Bitte beachten Sie unsere beigefügten Serviceinformationen.

Als weiteres Zubehör lieferbar:

Gepäckbrücke Alu-Rack	650.4526 01 01
Hauptständer	505.4526 00 01
Kofferträger Lock it System	650.4526 00 01 (abnehmbar)
Lampenschutzgitter	700.4526 00 01
Zusatzscheinwerfer	Micro Flooter



Hepco & Becker GmbH
An der Steinmauer 6

D-66955 Pirmasens

Tel.: 06331 - 1453 - 100

Fax: 06331 - 1453 - 120

eMail: vertrieb@hepco-becker.de

www.hepco-becker.de

Engine guard
YAMAHA XT 660 Z Ténéré

Item - No.:
502.405 00 01 black

Side cases
Top cases
luggage frames
Lock it system
Softbags
Aluminium luggage
Leather luggage
Protection bars
Center stands
Chopper parts
Quad parts
Accessories



Assembling instructions

The kit includes the following parts:

Quant	item no.	description
1	704.517HB	Engine guard, left
1	704.518HB	Engine guard, right
1	704.519HB	Bracing bow
1	151.457	Hexagon bolt M10 x 100
1	151.184	Hexagon bolt M10 x 90
1	151.183	Hexagon bolt M10 x 75
2	150.782	Allen screw M8 x 20
2	150.788	Allen screw M8 x 50
6	150.811	Washer ø10,5
6	150.810	Washer ø8,4
3	150.801	Self-lock nut M10
2	150.800	Self-lock nut M8

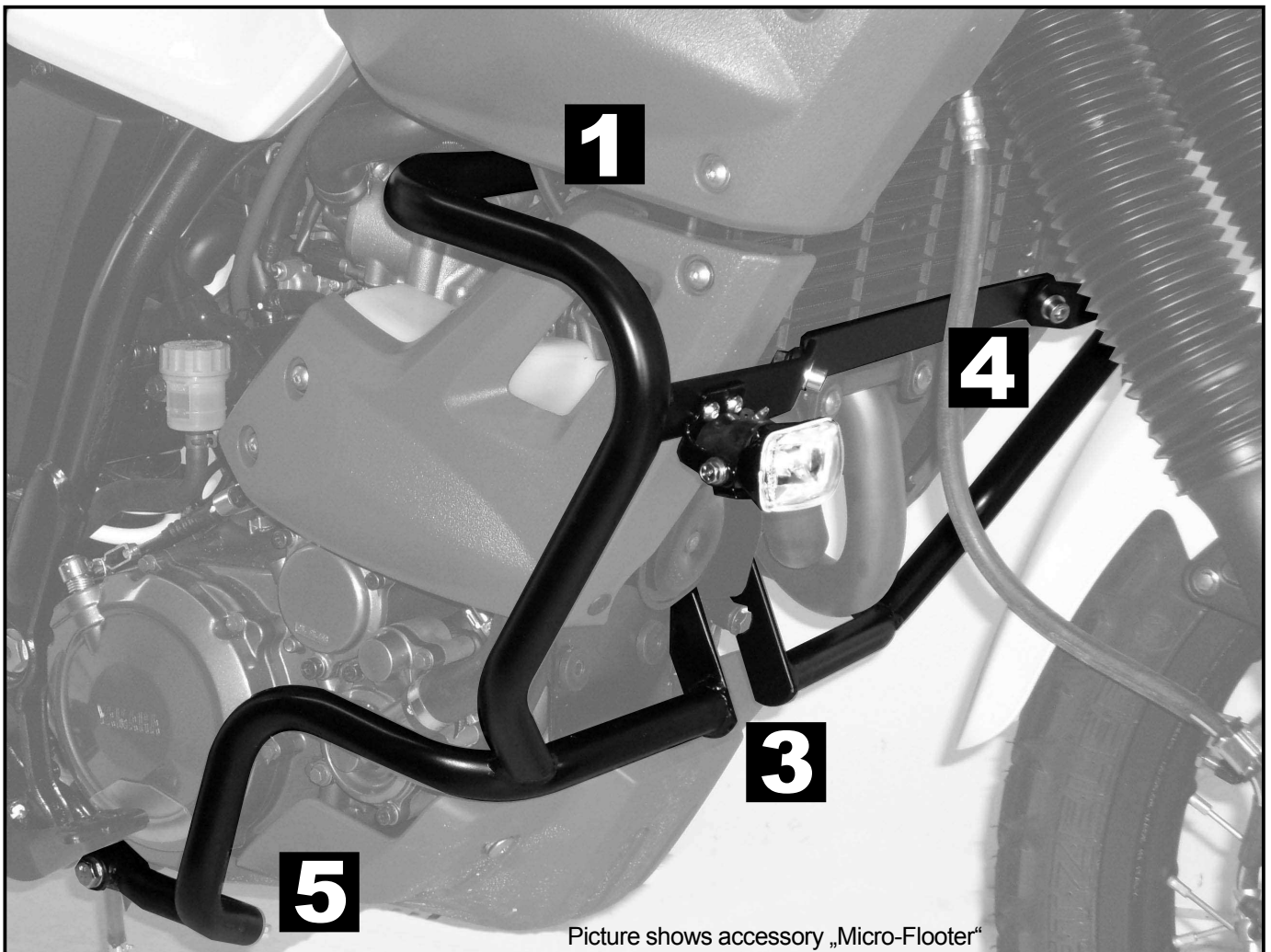

Picture shows accessory „Micro-Floater“

Engine guard
YAMAHA XT 660 Z Ténéré

Item - No.:
502.405 00 01 black

Side cases
Top cases
luggage frames
Lock it system
Softbags
Aluminium luggage
Leather luggage
Protection bars
Center stands
Chopper parts
Quad parts
Accessories



Assembling instructions

Preparing:

- Dismantle tank cover left and right.
- Dismantle control unit under the signal-horn.
- Unscrew the original bolt of the lower engine suspension.
- Unscrew the original bolts of the plastic engine protector.

Tip:

Fit all parts and screw on not too strong. After mounting all parts, the screws should be tightened to the torque specified. This guarantees, that the kit is mounted without tension.

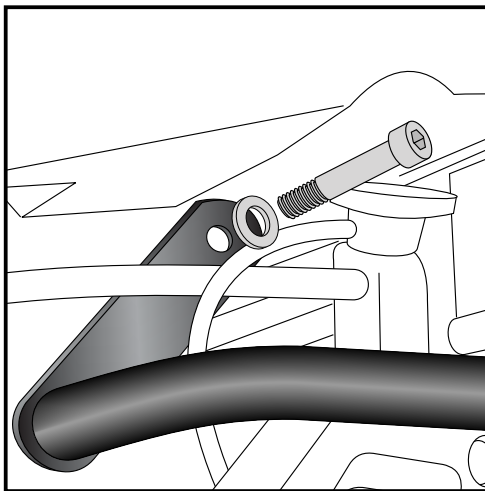

1

Fastening of the engine guard right top:

At the original lower tank suspension - original screw is obsolete.
Use allen screw M8 x 50 with washer $\varnothing 8,4$.



each 1x

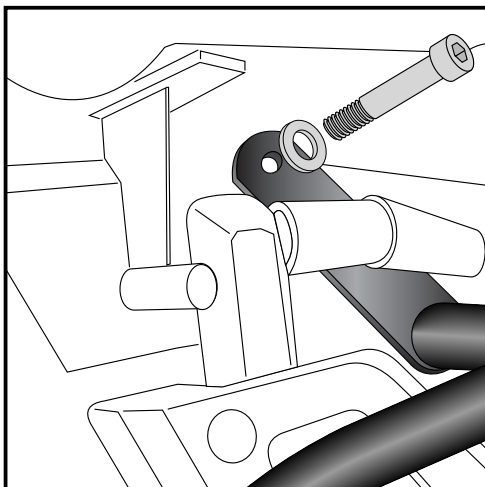
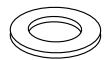

2

Fastening of the engine guard left top:

At the original lower tank suspension - original screw is obsolete.
Use allen screw M8 x 50 with washer $\varnothing 8,4$.

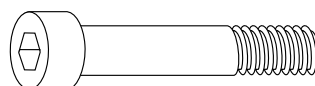

each 1x



Engine guard
YAMAHA XT 660 Z Ténéré

Item - No.:
502.405 00 01 black

- Side cases
- Top cases
- Luggage frames
- Lock it system
- Softbags
- Aluminium luggage
- Leather luggage
- Protection bars
- Center stands
- Chopper parts
- Quad parts
- Accessories



Assembling instructions

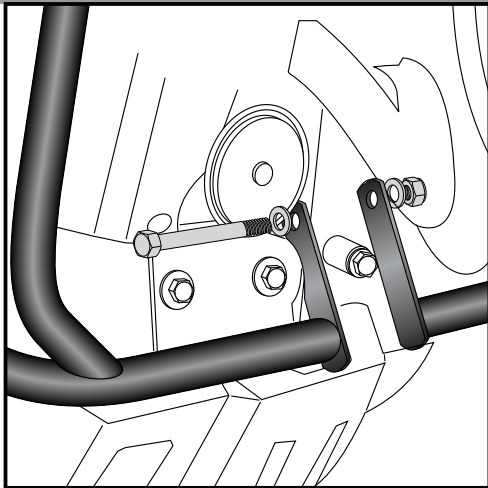

3

Fastening of the engine guard middle:

At the original position of the lower engine suspension bolting with hexagon screw M10 x 90, washers $\varnothing 10,5$ und self-lock nut M10.

Mount the parts as shown - screw at the right side, nut on the left!

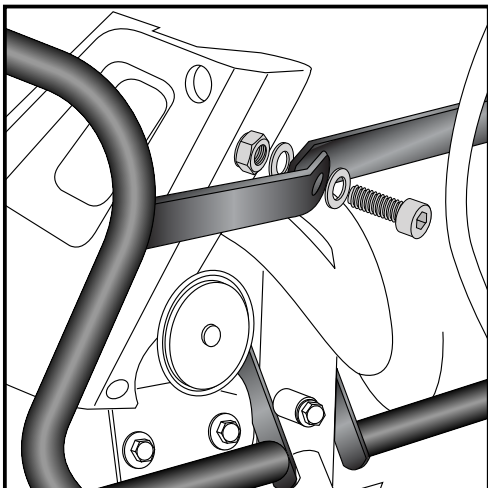

4

Fastening of the bracing bow middle left and right:

Under the cooler between the two engine bars with allen screws M8 x 20, washers $\varnothing 8,4$ und self-lock nuts M8.

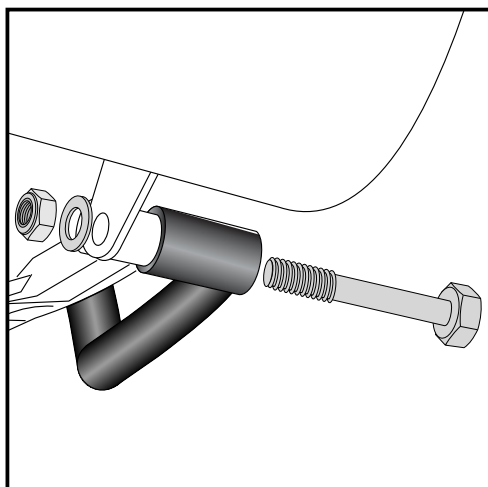

5

Fastening of the engine guard right bottom:

At the rear original position of the engine protector.

Use hexagon screw M10 x 100, washers $\varnothing 10,5$ und self-lock nut M10.

Mount the screw as shown from outside !



Engine guard
YAMAHA XT 660 Z Ténéré

Item - No.:
502.405 00 01 black

Side cases
Top cases
luggage frames
Lock it system
Softbags
Aluminium luggage
Leather luggage
Protection bars
Center stands
Chopper parts
Quad parts
Accessories



Assembling instructions

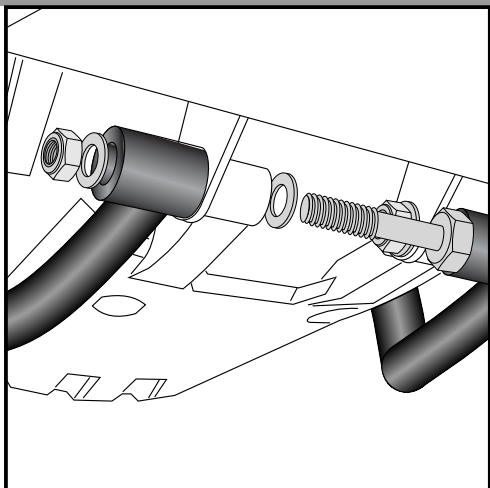

6

Fastening of the engine guard left bottom:

At the rear original position of the engine protector.

Use hexagon screw M10 x 75, washers $\varnothing 10,5$ und self-lock nut M10.

Mount the screw as shown from inside !

Mount control unit under the signal-horn and tank cover left and right again.



Control all screw connections after the assembling for tightness!
Please notice our enclosed service information.

Also available:

Rear rack aluminium

650.4526 01 01

Centre stand

505.4526 00 01

Side carrier Lock it System

650.4526 00 01 (removable)

Headlight grille

700.4526 00 01

Additional light kit

Micro Flooter



Hepco & Becker GmbH
An der Steinmauer 6
D-66955 Pirmasens
Germany

Tel.: +49 6331 - 1453 - 100

Fax: +49 6331 - 1453 - 120

eMail: vertrieb@hepco-becker.de

www.hepco-becker.de