

Motorschutzbügel inkl. ProtectionPad



KRAUSER[®]
MOTORRADGEPÄCKSYSTEME ■ BIKE BAGS

YAMAHA MT - 07

501.4537 00 05 anthrazit

YAMAHA MT - 07

3004.048.105 anthrazit

Montage

Der Bausatz umfaßt die folgenden Teile:

| Stück | Bestellnr. | Bezeichnung | | | | |
|-------|------------|---------------------------------|----------------|--|---|-----------------------|
| 1 | 700008579 | Motorschutzbügel links | 1 | 507.001 ProtectionPad Set li/re, schwarz | | |
| 1 | 700008580 | Motorschutzbügel rechts | bestehend aus: | | | |
| 2 | 151.366 | Inbusschrauben M12 x 140 x 1,25 | 1 | Padkopf links | 1 | Padkopf rechts |
| 4 | 150.783 | Inbusschrauben M8 x 25 | 1 | Polymerelement links | 1 | Polymerelement rechts |
| 4 | 150.995 | U-Scheiben ø8,4 | 1 | Logo-Blende links | 1 | Logo-Blende rechts |
| | | | 2 | Hülse ø13 mm | | |



Als weiteres Zubehör lieferbar:
Kofferträger (Lock it System, abnehmbar)
Gepäckbrücke
C-Bow Halter für Softtaschen
Fußrasten Tieferlegung

Anzugsmomente des Motorradherstellers beachten!
Nach der Montage alle Verschraubungen auf festen Sitz kontrollieren!
Bitte beachten Sie unsere beigefügten Serviceinformationen.



Hepco & Becker GmbH
An der Steinmauer 6
D-66955 Pirmasens
Tel.: 0049 6331 - 1453 - 100
www.hepco-becker.de



Krauser GmbH
An der Steinmauer 6
D-66955 Pirmasens
Tel.: 0049 6331 - 1453 - 250
www.krauser.de

YAMAHA MT - 07

501.4537 00 05 anthrazit

YAMAHA MT - 07

3004.048.105 anthrazit

Montage

Vorbereitung:

Der Protection Pad - Kopf muß vor der Befestigung am Halter zusammengebaut werden.

Zuerst die Hülse einsetzen. ①
Anschließend das Polymerelement einschieben. ②

Bitte Reihenfolge beachten!

1

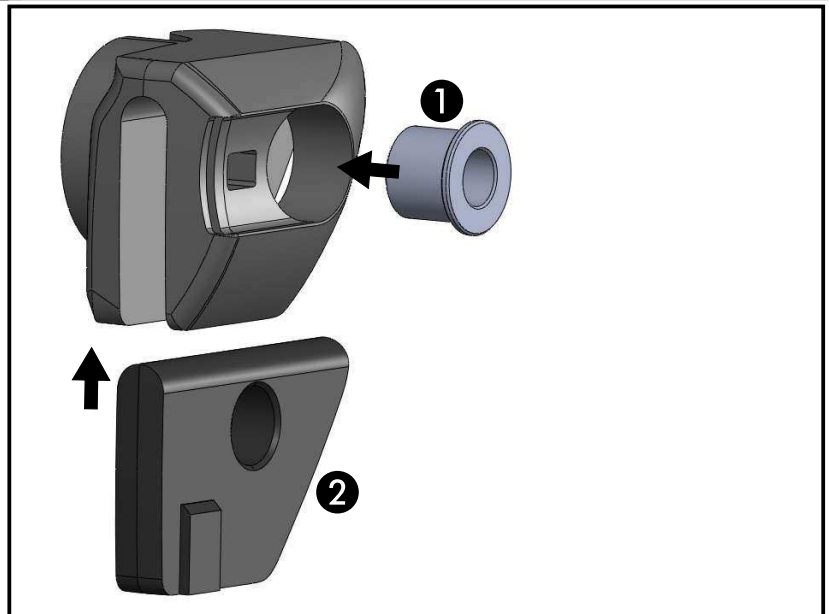

RECHTE SEITE

Vorbereitung Montage rechts:

Die Schrauben der vorderen Motoraufhängung ausdrehen.
Die zwei Schrauben der mittleren Aufhängung am Rahmen ausdrehen.
Die Originalschrauben entfallen.

Montage hinten rechts:

Den Motorschutzbügel mit den Inbusschrauben M8x25 sowie U-Scheiben $\varnothing 8,4$ verschrauben.

2

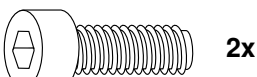
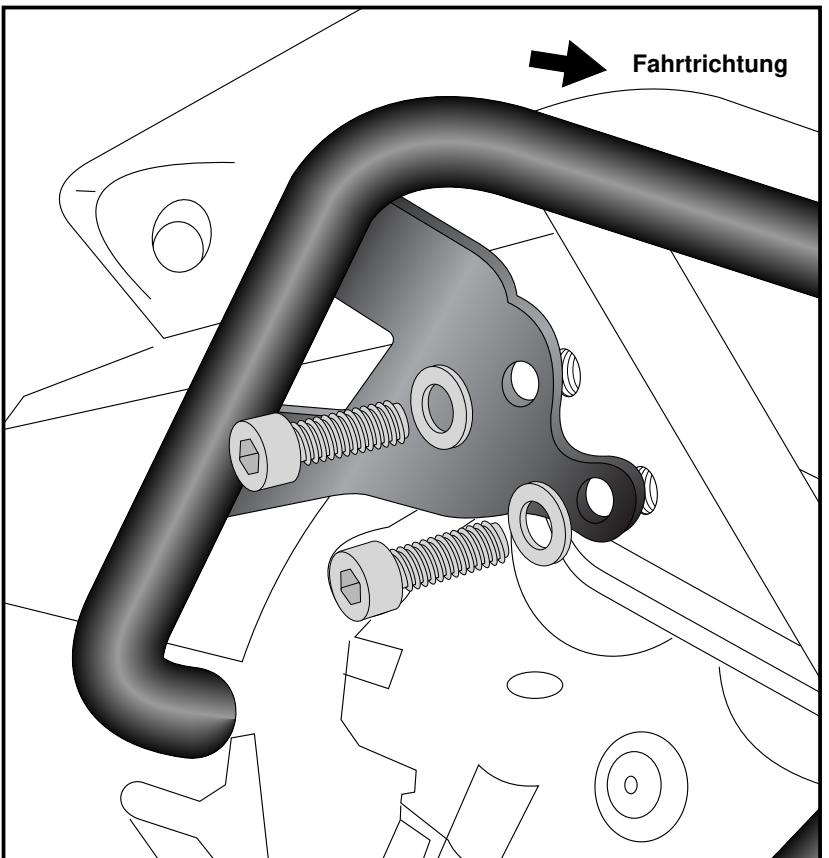

Motorschutzbügel inkl. ProtectionPad



KRAUSER[®]
MOTORRADGEPÄCKSYSTEME ■ BIKE BAGS

YAMAHA MT - 07

501.4537 00 05 anthrazit

YAMAHA MT - 07

3004.048.105 anthrazit

Montage

Montage vorne rechts:

Den Motorschutzbügel mit den Inbusschrauben M12 x 140 x 1,25 zusammen mit dem in Schritt 1 zusammengebauten ProtectionPad befestigen.

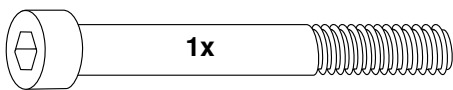

3

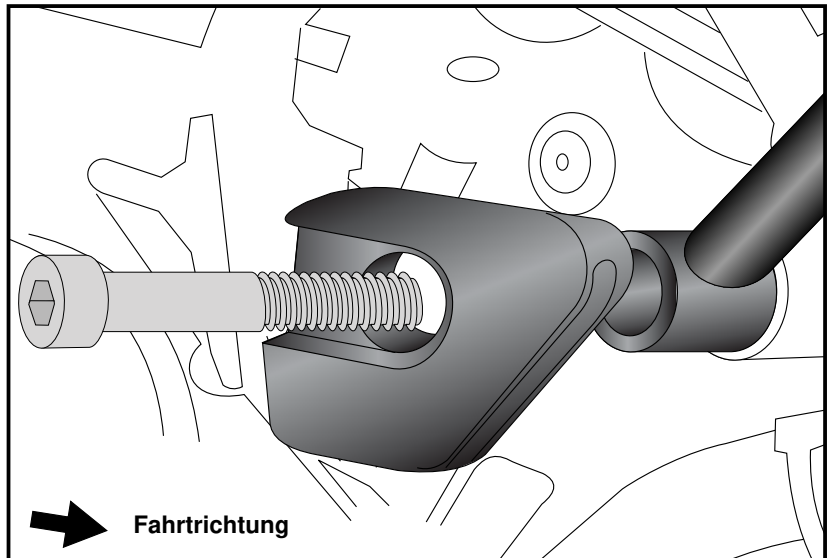

Nach abgeschlossener Montage die Logo-Blende einsetzen.

4

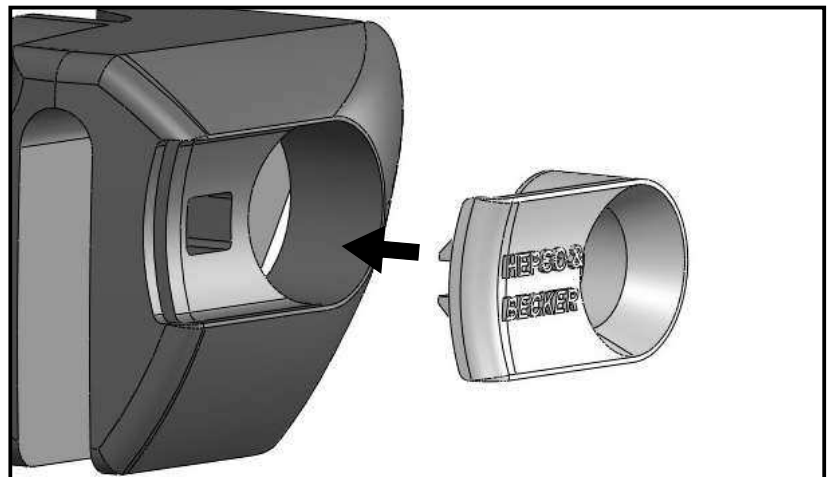

LINKE SEITE

Befestigung Motorschutzbügel links:
wie rechts

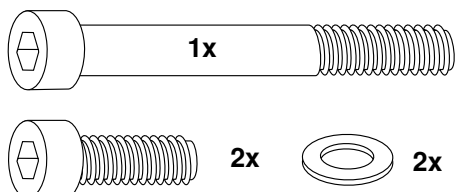

Achtung ! Immer nur eine Seite nach der anderen montieren. Ansonsten besteht die Gefahr, dass sich der Motor absenkt.

Engine guard with ProtectionPad



KRAUSER[®]
MOTORRADGEPÄCKSYSTEME ■ BIKE BAGS

YAMAHA MT - 07

501.4537 00 05 anthracite

YAMAHA MT - 07

3004.048.105 anthrazit

Assembling instructions

The kit includes the following parts:

| Quant | item no. | description | |
|-----------|----------------------|------------------------------|-----------------------|
| 1 | 700008579 | engine guard left | |
| 1 | 700005880 | engine guard right | |
| 2 | 151.366 | allen screw M12 x 140 x 1,25 | |
| 4 | 150.783 | allen screw M8 x 25 | |
| 4 | 150.995 | washer ø 8,4 | |
| 1 | 507.001 | ProtectionPad Set black | |
| included: | | | |
| 1 | Pad left | 1 | Pad right |
| 1 | Polymer element left | 1 | Polymer element right |
| 1 | cover left | 1 | cover right |
| 2 | spacer ø13 mm | | |

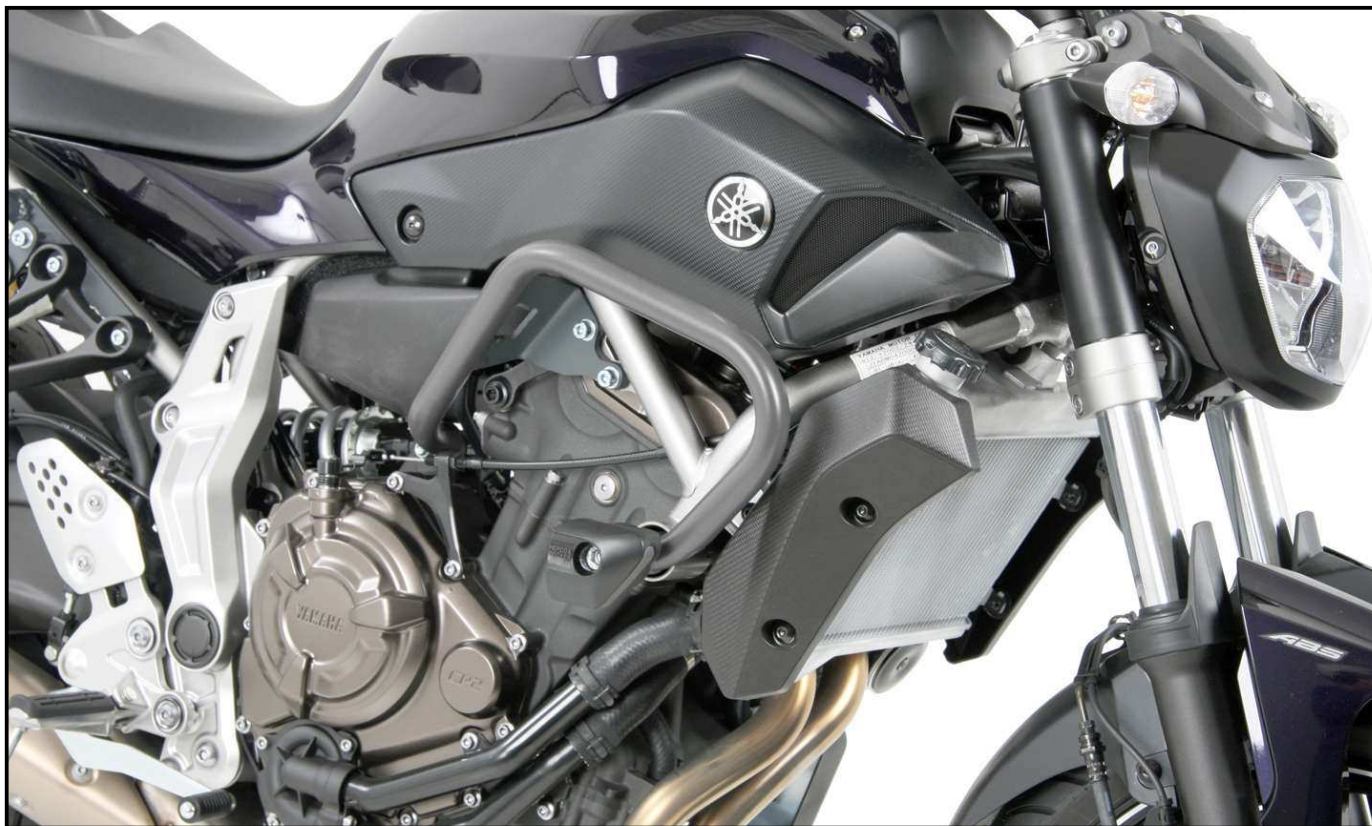

Also available:
Side carrier (Lock it System, removable)
Rear rack
C-Bow Holder for softbags
Footrest lowering set

**Control all screw connections after the assembling for tightness!
Please notice our enclosed service information.**



Hepco & Becker GmbH
An der Steinmauer 6
D-66955 Pirmasens
Tel.: 0049 6331 - 1453 - 100
www.hepco-becker.de



Krauser GmbH
An der Steinmauer 6
D-66955 Pirmasens
Tel.: 0049 6331 - 1453 - 250
www.krauser.de

Engine guard with ProtectionPad



KRAUSER[®]
MOTORRADGEPÄCKSYSTEME ■ BIKE BAGS

YAMAHA MT - 07

501.4537 00 05 anthracite

YAMAHA MT - 07

3004.048.105 anthrazit

Assembling instructions

Preparing:

The Protection Pad kit must be assembled before attaching the holder.

First insert the spacer. ①
Then push in the polymer element. ②

Please note the sequence !

1

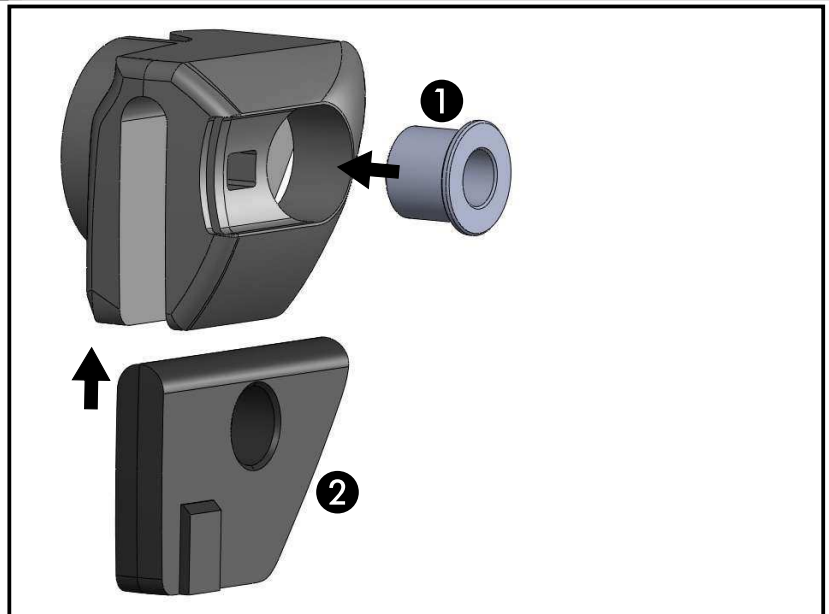

RIGHT SIDE

Preparing:

Unscrew the screws of the front engine mount and the two screws on the frame of the middle suspension.
The original screws are obsolete.

Fastening of the engine guard rear right:
with allen screws M8x25 and washers
ø8,4.

2

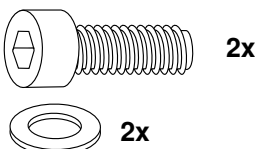
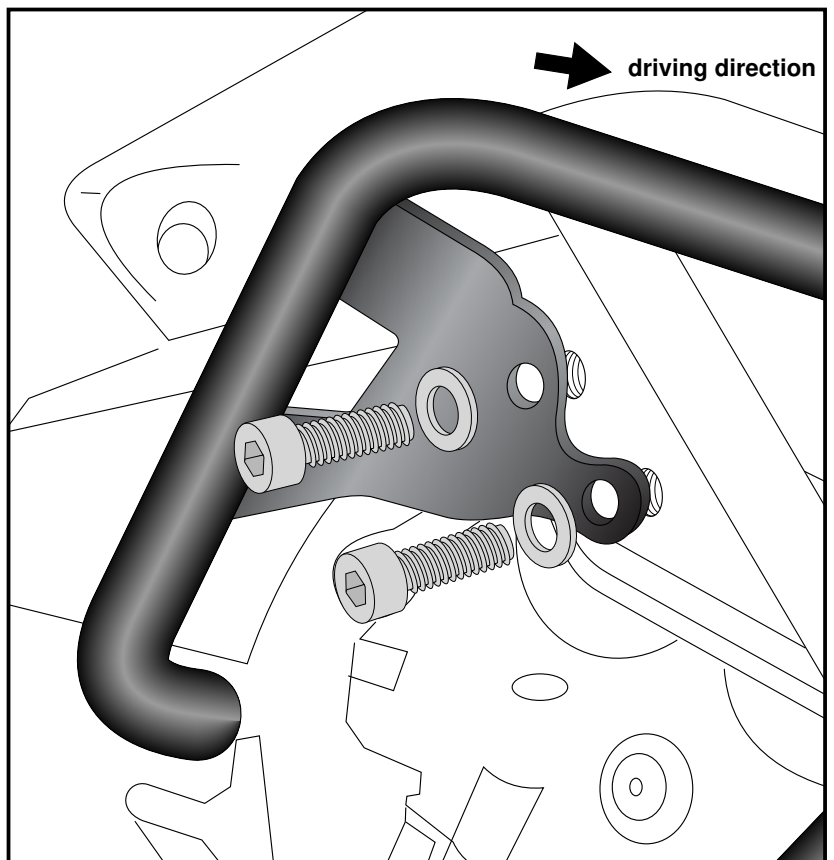

Engine guard with ProtectionPad



KRAUSER[®]
MOTORRADGEPÄCKSYSTEME ■ BIKE BAGS

YAMAHA MT - 07

501.4537 00 05 anthracite

YAMAHA MT - 07

3004.048.105 anthrazit

Assembling instructions

3 Fastening of the engine guard front right:
with allen screws M12 x 140 x 1,25
together with the prepared (step 1)
ProtectionPads.

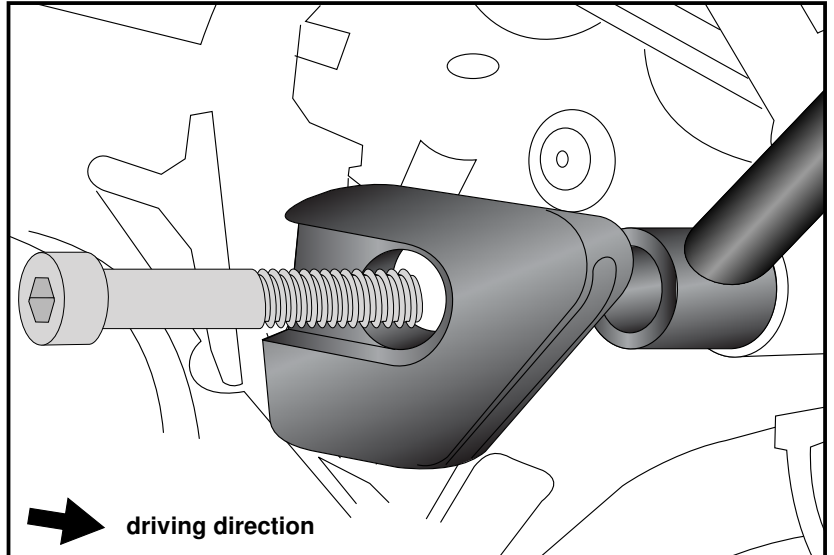
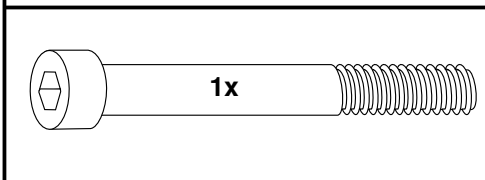

After finishing the mounting, insert the
cover.

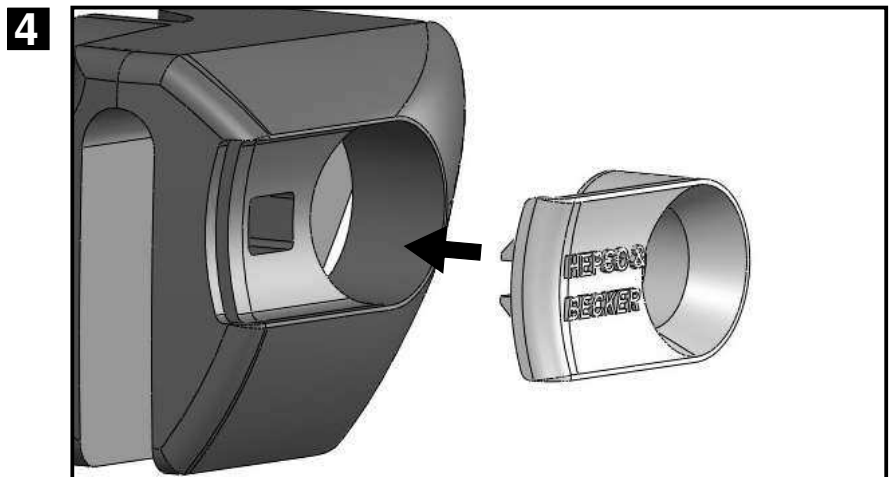

LINKE SEITE

Fastening of the engine guard left:
like right side

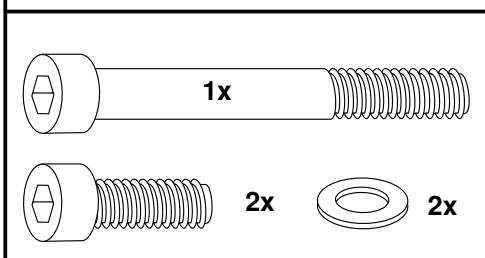

Attention!
Mount one side after the other. Otherwise, there is the
risk that the engine block change position.