

Motorschutzbügel inkl. ProtectionPad



KTM 690 Duke

501.7510 00 06 orange

KRAUSER[®]
MOTORRADGEPÄCKSYSTEME ■ BIKE BAGS

KTM 690 Duke

3011.008.101 orange

Montage

Der Bausatz umfaßt die folgenden Teile:

Stück	Bestellnr.	Bezeichnung				
1	1700008414	Motorschutzbügel links	4 150.956	U-Scheiben Ø10,5		
1	1700008415	Motorschutzbügel rechts	4 150.810	U-Scheiben Ø6,4		
1	1151.435	Inbusschrauben M10x170	2 151.113	Aludistanzen Ø18xØ11x10mm		
2	2150.868	Inbusschrauben M10x45	1 507.0001	ProtectionPad Set li/re, schwarz		
4	4150.896	Linsenkopfschrauben M6x50	bestehend aus:			
3	3150.801	selbstsichernde Muttern M10	1	Padkopf links	1	Padkopf rechts
2	151.408	Kunststoff- Klemmbacken-Satz Ø28 mit Gewindeplatte	1	Polymerelement links	1	Polymerelement rechts
			1	Logo-Blende links	1	Logo-Blende rechts
			2	Hülse ø11 mm		



Als weiteres Zubehör lieferbar:
Gepäckbrücke
C-Bow Halter für Softtaschen
Sportrack
Ritzelschutz

Anzugsmomente des Motorradherstellers beachten!
Nach der Montage alle Verschraubungen auf festen Sitz kontrollieren!
Bitte beachten Sie unsere beigefügten Serviceinformationen.



Hepco & Becker GmbH
An der Steinmauer 6
D-66955 Pirmasens
Tel.: 0049 6331 - 1453 - 100
www.hepco-becker.de



Krauser GmbH
An der Steinmauer 6
D-66955 Pirmasens
Tel.: 0049 6331 - 1453 - 250
www.krauser.de

Motorschutzbügel inkl. ProtectionPad



KTM 690 Duke

501.7510 00 06 orange

KRAUSER
MOTORRADGEPÄCKSYSTEME ■ BIKE BAGS

KTM 690 Duke

3011.008.101 orange

Montage

Vorbereitung:

Der Protection Pad - Kopf muß vor der Befestigung am Motorschutzbügel zusammengebaut werden.

Zuerst die Hülse einsetzen. ①
Anschließend das Polymerelement einschieben. ②
Zuletzt die Logo-Blende einsetzen. ③

Bitte Reihenfolge beachten!

1

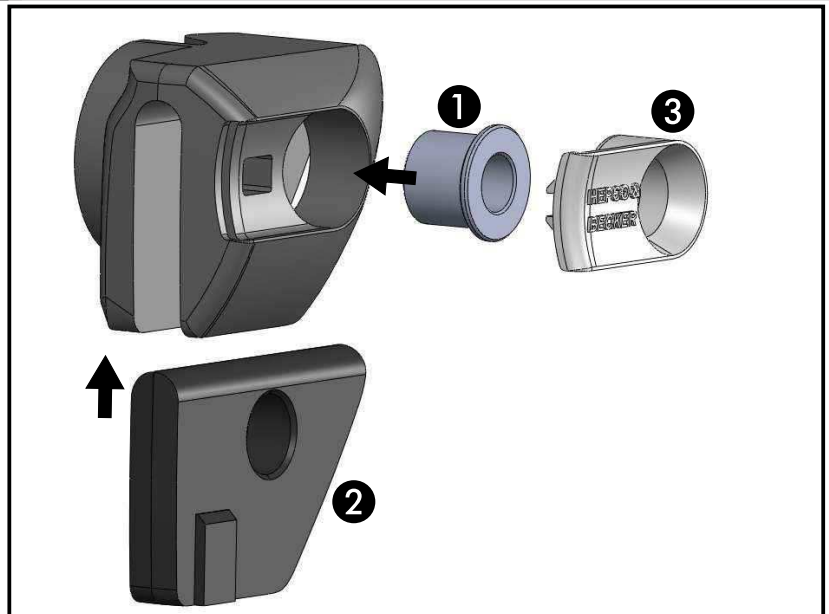

Befestigung vorne unten links:

Die Originalschraube der Motoraufhängung unterhalb des Kühlers demontieren (entfällt).

Hierbei muss der Krümmer oben und unten gelöst werden und etwas gedreht werden, damit die Schraube entfernt werden kann.

Nach dem Entnehmen der Schraube den Krümmer wieder montieren.

Nun die mitgelieferte Inbusschraube M10x170 sowie die U-Scheibe Ø10,5 von der linken Seite her mit dem linken Motorschutzbügel montieren.

Zwischen Lasche und Motoraufhängung die Aludistanz Ø18xØ11x10 mm fügen.

2

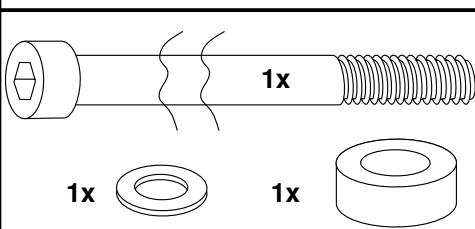
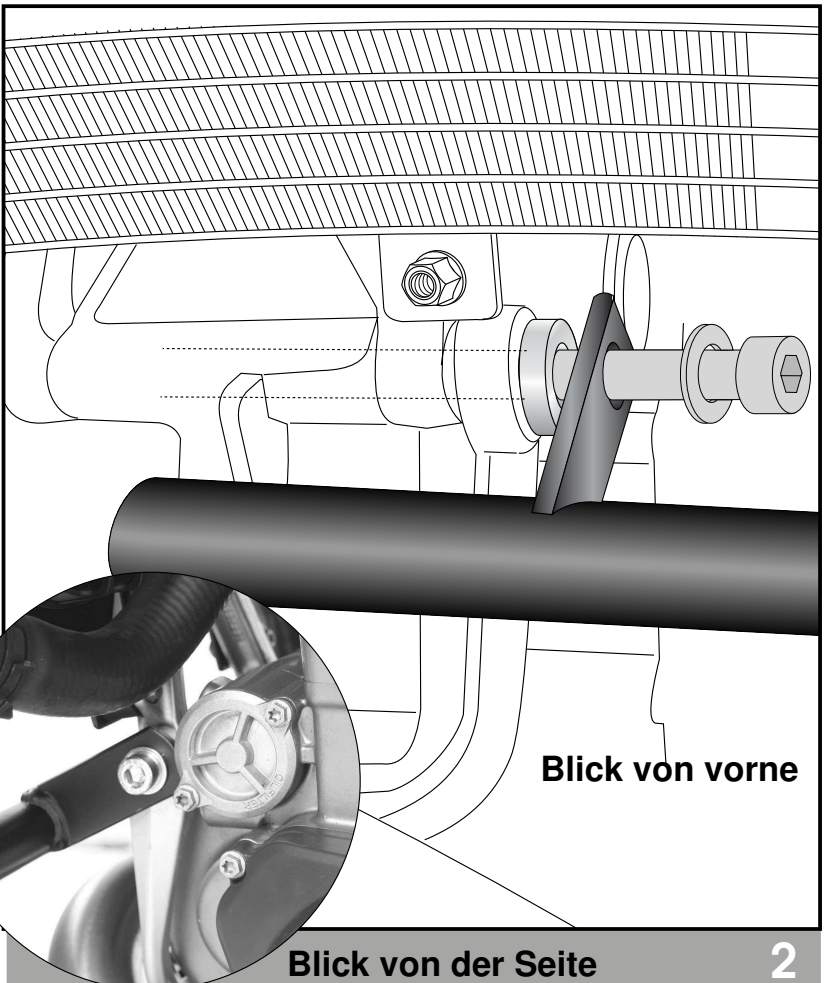

Blick von der Seite

2

Motorschutzbügel inkl. ProtectionPad



KTM 690 Duke

501.7510 00 06 orange

KRAUSER[®]
MOTORRADGEPÄCKSYSTEME ■ BIKE BAGS

KTM 690 Duke

3011.008.101 orange

Montage

Befestigung vorne unten rechts:
auf das überstehende Gewinde den
rechten Bügel fügen und mit der
selbtsichernden Mutter M10 sowie
U-Scheibe $\text{\O}10,5$ verschrauben.
Vor dem Motor die beiden Bügel
zusammen stecken.
Zwischen Lasche und Motoraufhängung
die Aludistanz $\text{\O}18 \times \text{\O}11 \times 10 \text{mm}$ fügen.

Noch nicht ganz festziehen.

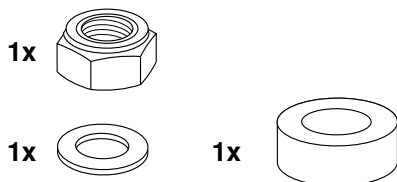

3 Blick von vorne

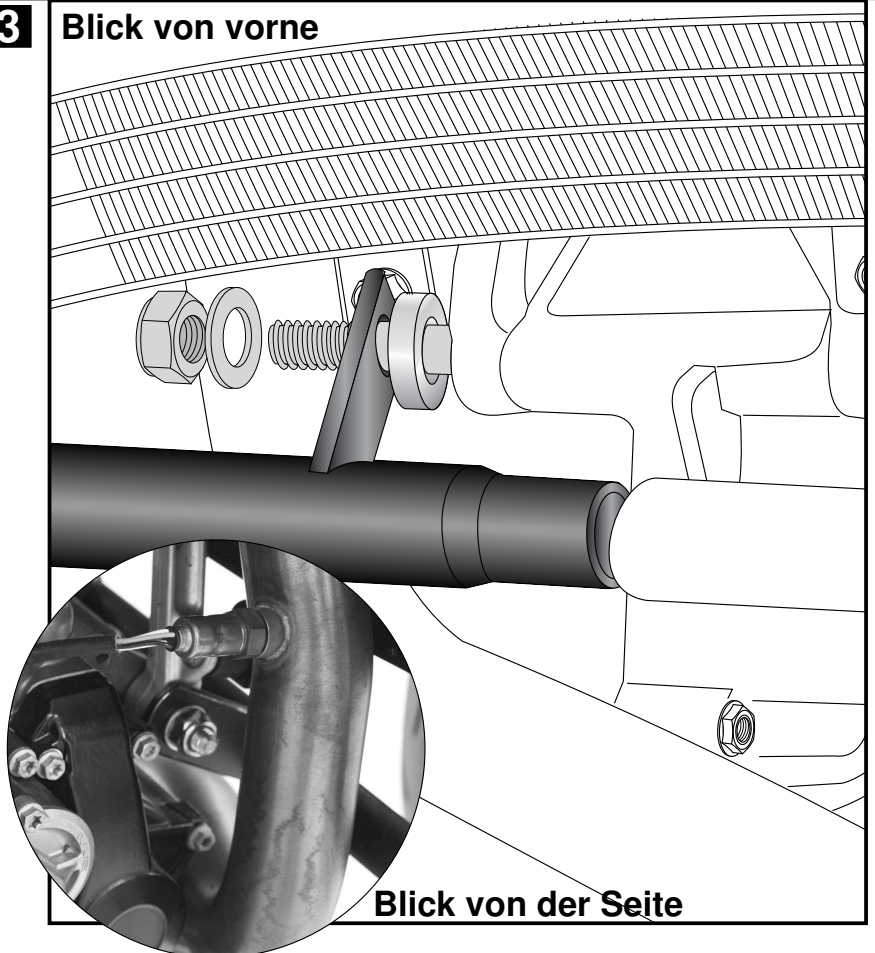

Blick von der Seite

Befestigung oben links und rechts:
Am Rahmen mit den Klemmbacken $\text{\O}28$
sowie Linsenkopfschrauben M6x50 und
U-Scheiben $\text{\O}6,4$

Nun alle Schrauben festziehen.

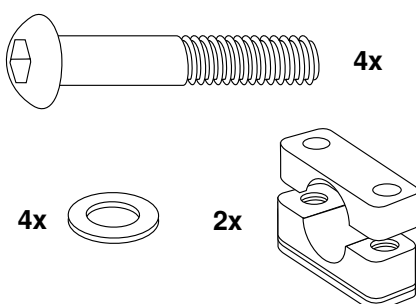

4

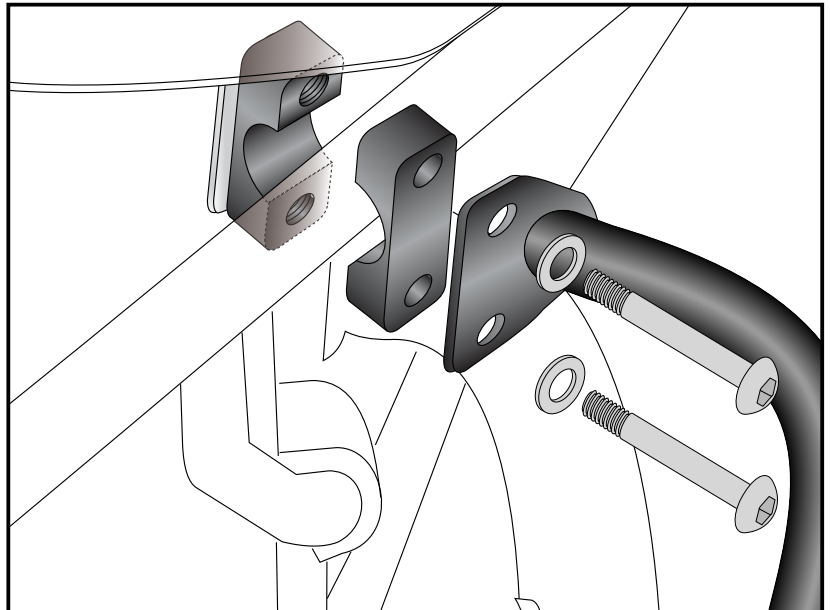

Motorschutzbügel inkl. ProtectionPad



KTM 690 Duke

501.7510 00 06 orange

KRAUSER[®]
MOTORRADGEPÄCKSYSTEME ■ BIKE BAGS

KTM 690 Duke

3011.008.101 orange

Montage

Befestigung der ProtectionPads am
Motorschutzbügel links und rechts:
mit den Inbusschrauben M10 x 45. Von
der Rückseite mit den U-Scheiben Ø10,5
und selbstsichernden Muttern M10
verschrauben.

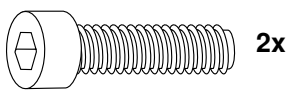

2x



2x

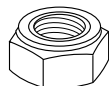

5

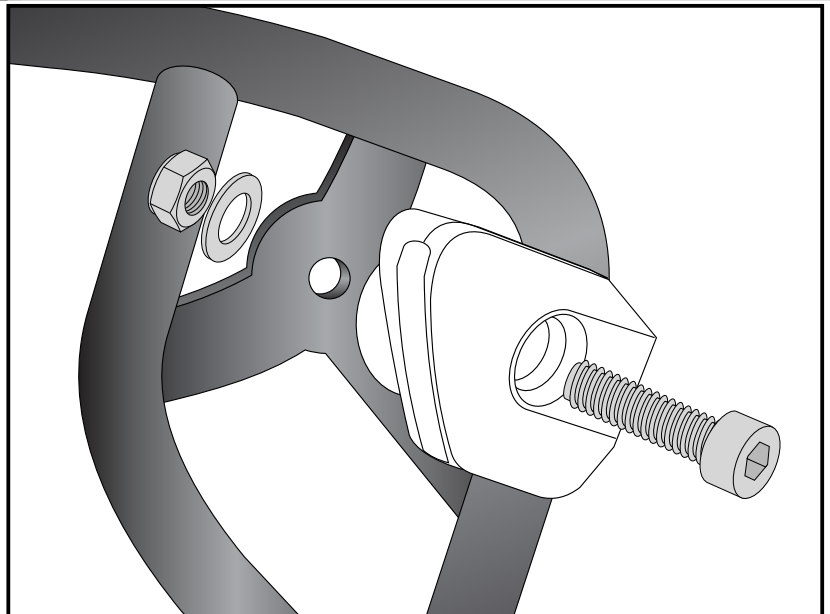

Engine guard with ProtectionPad



KTM 690 Duke

501.7510 00 06 orange

KRAUSER[®]
MOTORRADGEPÄCKSYSTEME ■ BIKE BAGS

KTM 690 Duke

3011.008.101 orange

Assembling instructions

The kit includes the following parts:

Quant	item no.	description	
1	700008414	engine guard left	
1	700008415	engine guard right	
1	151.435	allen screw M10x170	
2	150.868	allen screw M10x45	
4	150.896	filister head screw M6x50	
3	150.801	self lock nut M10	
2	151.408	frame adapter Ø28	
4	150.956	washer Ø10,5	
4	150.810	washer Ø6,4	
2	151.113	alu spacer Ø18xØ11x10mm	
1	1507.0001	ProtectionPad Set black	
included:			
1	Pad left	1	Pad right
1	Polymer element left	1	Polymer element right
1	cover left	1	cover right
2	spacer ø11 mm		



Also available:

- Rear rack
- C-Bow Holder for softbags
- Sportrack
- Pinion protection

**Control all screw connections after the assembling for tightness!
Please notice our enclosed service information.**



Hepco & Becker GmbH
An der Steinmauer 6
D-66955 Pirmasens
Tel.: 0049 6331 - 1453 - 100
www.hepco-becker.de



Krauser GmbH
An der Steinmauer 6
D-66955 Pirmasens
Tel.: 0049 6331 - 1453 - 250
www.krauser.de

Engine guard with ProtectionPad



KTM 690 Duke

501.7510 00 06 orange

KRAUSER
MOTORRADGEPÄCKSYSTEME ■ BIKE BAGS

KTM 690 Duke

3011.008.101 orange

Assembling instructions

Preparing:

The Protection Pad kit must be assembled before attaching the holder.

First insert the spacer. ①

Then push in the polymer element. ②

At last insert the cover. ③

Please note the sequence !

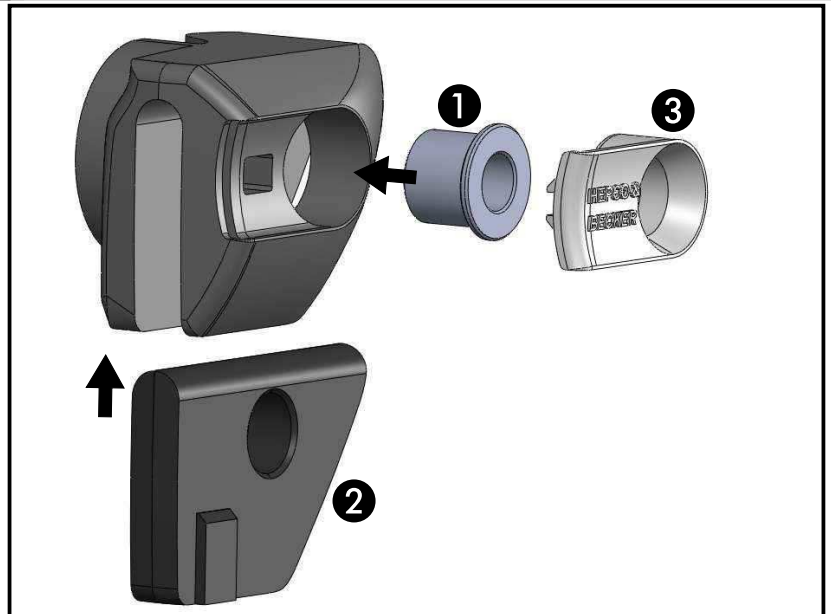

Fastening of the engine guard

front bottom left:

Dismantle original screw of the engine bolting under the cooler, screw is obsolete.

Notice: the exhaust manifold has to be loosened and to be rotated slightly so that the screw can be removed.

After dismantling of the screw, mount the exhaust manifold again.

Now mount the supplied allen screw M10x170 and the washer Ø10, 5 from the left side with the left engine guard. Add alu spacer Ø18xØ11x10 mm between flap and engine mount.

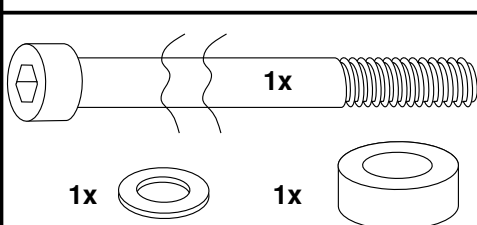

2

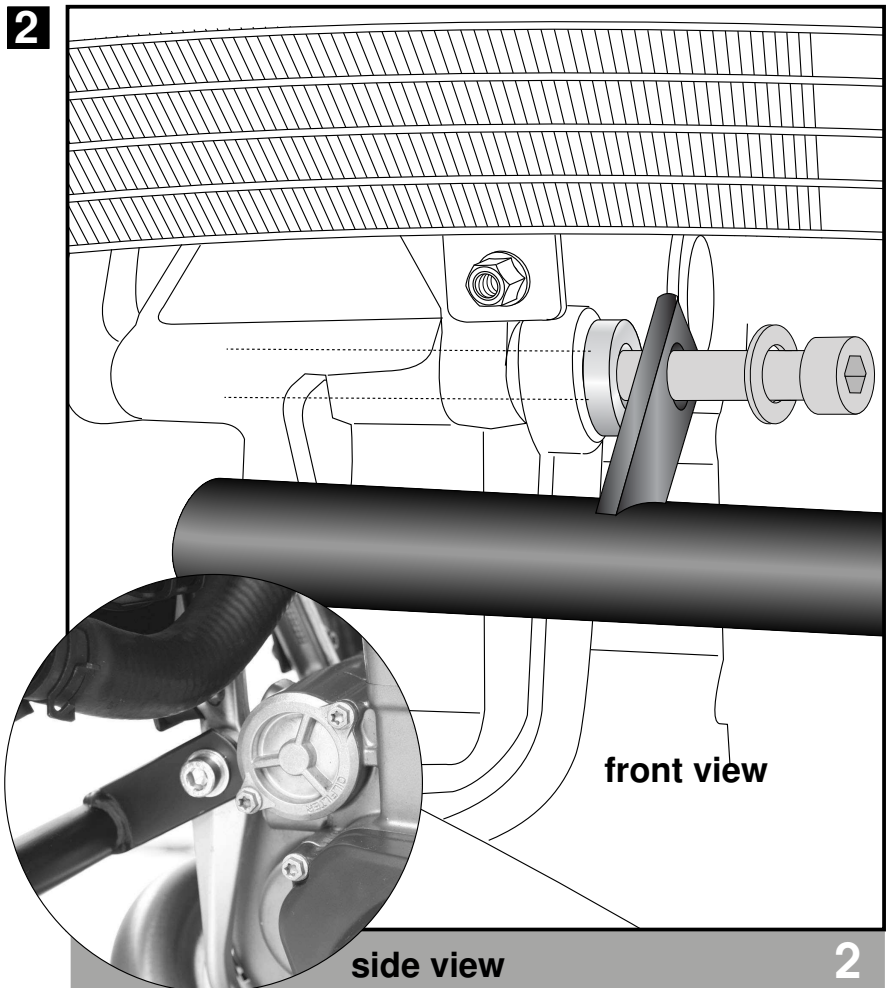

2

Engine guard with ProtectionPad



KTM 690 Duke

501.7510 00 06 orange

KRAUSER
MOTORRADGEPÄCKSYSTEME ■ BIKE BAGS

KTM 690 Duke

3011.008.101 orange

Assembling instructions

Fastening of the engine guard front bottom right:
add on the exposed thread of the screw, mounted in step 1 the right engine guard and secure it with the self-locking nut M10 and washer $\varnothing 10$, 5.

Stuck the two engine guards together in front of the engine block.

Add alu spacer $\varnothing 18 \times \varnothing 11 \times 10$ mm between flap and engine mount.

1x



1x



1x



3 front view

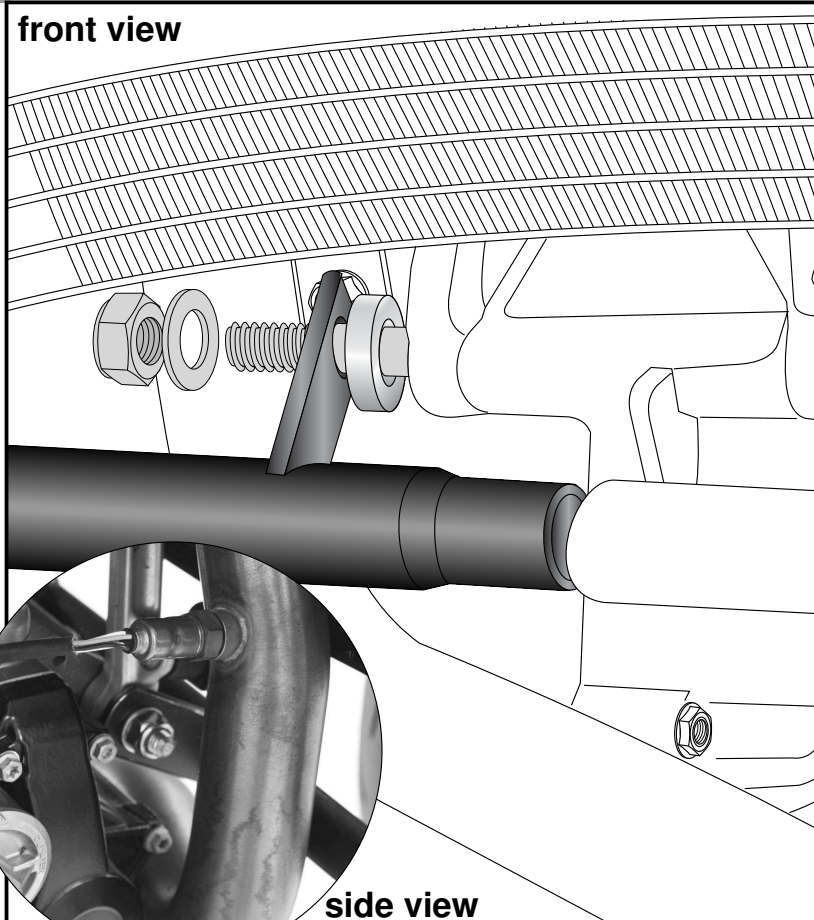

side view

Fastening of the engine guard top left + right:
at the frame tube with the frame adapters $\varnothing 28$ mm and filister head screws M6x50 with washers $\varnothing 6,4$.

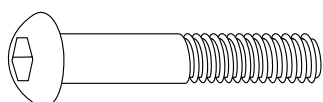

4x

4x



2x

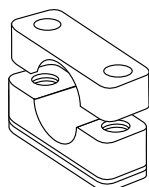

4

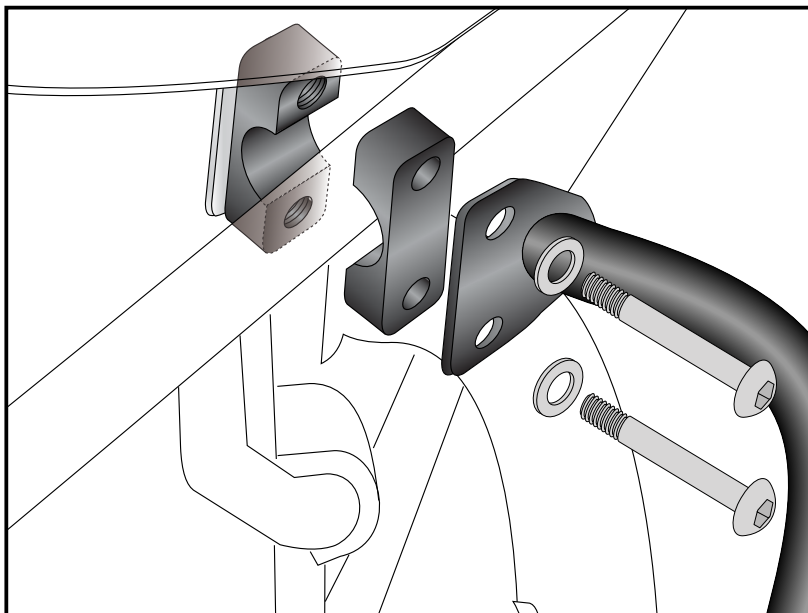

Engine guard with ProtectionPad



KTM 690 Duke

501.7510 00 06 orange

KRAUSER[®]
MOTORRADGEPÄCKSYSTEME ■ BIKE BAGS

KTM 690 Duke

3011.008.101 orange

Montage

Fastening of the ProtectionPads at the engine guard left + right:
with allwn screws M10 x 45. Secure with washer $\varnothing 10,5$ and self lock nuts M10.

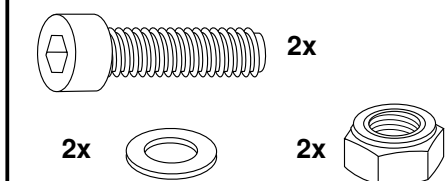

5

