

## Gepäckbrückenverbreiterung

YAMAHA XT 1200 Z Super Tenere  
bis Baujahr 2013

YAMAHA XT 1200 Z Super Ténéré  
YAMAHA XT 1200 ZE Super Ténéré  
ab Baujahr 2014

Artikel-Nr.: 800.4531 silber

Seitenkoffer  
Topcases  
Gepäckträger  
Lock it System  
Softbags  
Aluminiumkoffer  
Lederkoffer  
Schutzbügel  
Hauptständer  
Chopper-Parts  
Quad-Parts  
Accessoires



## Montageanleitung

Der Bausatz umfaßt die folgenden Teile:

Stück	Bestellnr.	Bezeichnung
1	700007804	Gepäckbrückenverbreiterung
2	151.358	Senkinbusschrauben M8x130
2	151.302	Senkinbusschrauben M8x25
4	151.302	Senkscheiben ø8,4 x ø25mm

Stück	Bestellnr.	Bezeichnung
2	151.219	Aludistanzen Ø20xØ9x13mm
2	151.220	Kunstoffscheibe Ø24xØ8,4x2mm
2	150.803	Tensilock-Mutter M8



**Anzugsmomente des Motorradherstellers beachten!**  
**Nach der Montage alle Verschraubungen auf festen Sitz kontrollieren!**  
**Bitte beachten Sie unsere beigefügten Serviceinformationen.**

Als weiteres Zubehör lieferbar:

Seitenträger Lock it (abnehmbar), Motorschutzbügel, Tankschutzbügel, Lampengitter, Motorschutzplatte, Griffschutz, Kardanschutzzug.....und viel weiteres Zubehör



**Heppo & Becker GmbH**  
**An der Steinmauer 6**  
**66955 Pirmasens**

**Tel.: 06331 - 1453 - 100**  
**Fax: 06331 - 1453 - 120**  
**eMail: [vertrieb@heppo-becker.de](mailto:vertrieb@heppo-becker.de)**  
**[www.heppo-becker.de](http://www.heppo-becker.de)**

## Gepäckbrückenverbreiterung

YAMAHA XT 1200 Z Super Tenere  
bis Baujahr 2013

YAMAHA XT 1200 Z Super Ténéré  
YAMAHA XT 1200 ZE Super Ténéré  
ab Baujahr 2014

Artikel-Nr.: 800.4531 silber

Seitenkoffer  
Topcases  
Gepäckträger  
Lock it System  
Softbags  
Aluminiumkoffer  
Lederkoffer  
Schutzbügel  
Hauptständer  
Chopper-Parts  
Quad-Parts  
Accessoires



## Montage

**1**  
Vorbereitung vorne: ①  
Die Original Schrauben lösen (entfallen)  
Aludistanzen Ø20xØ9x13 mm über der  
Bohrung positionieren.

Vorbereitung hinten: ②  
Kunststoffscheiben Ø24xØ8,4x2 mm über  
der Bohrung positionieren.

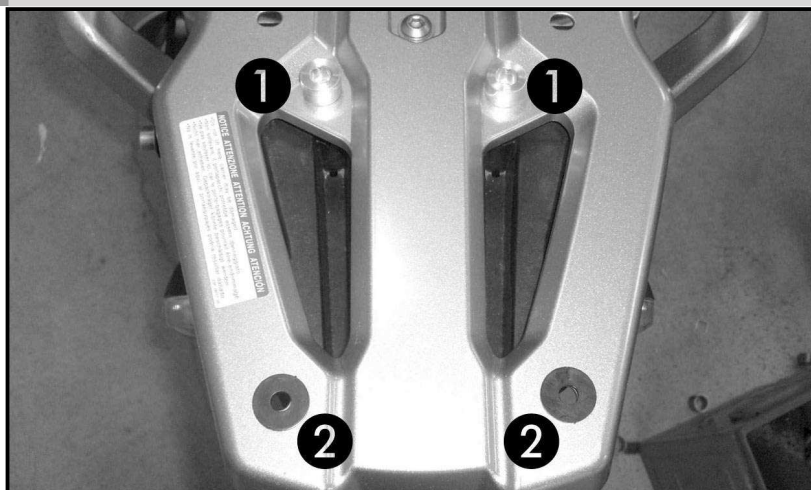

**2**  
Befestigung der Verbreiterung vorne: ③  
Zur Verschraubung die Senkinbus-  
schrauben M8x 130 sowie Senkscheiben  
Ø8,4 verwenden.

Befestigung der Verbreiterung hinten: ④  
An den freien Bohrungen der Original  
Brücke mit den Senkinbusschrauben  
M8x25 sowie Senkscheiben Ø8,4.  
Von unten mit den Tensilock-Muttern M8  
verschrauben.

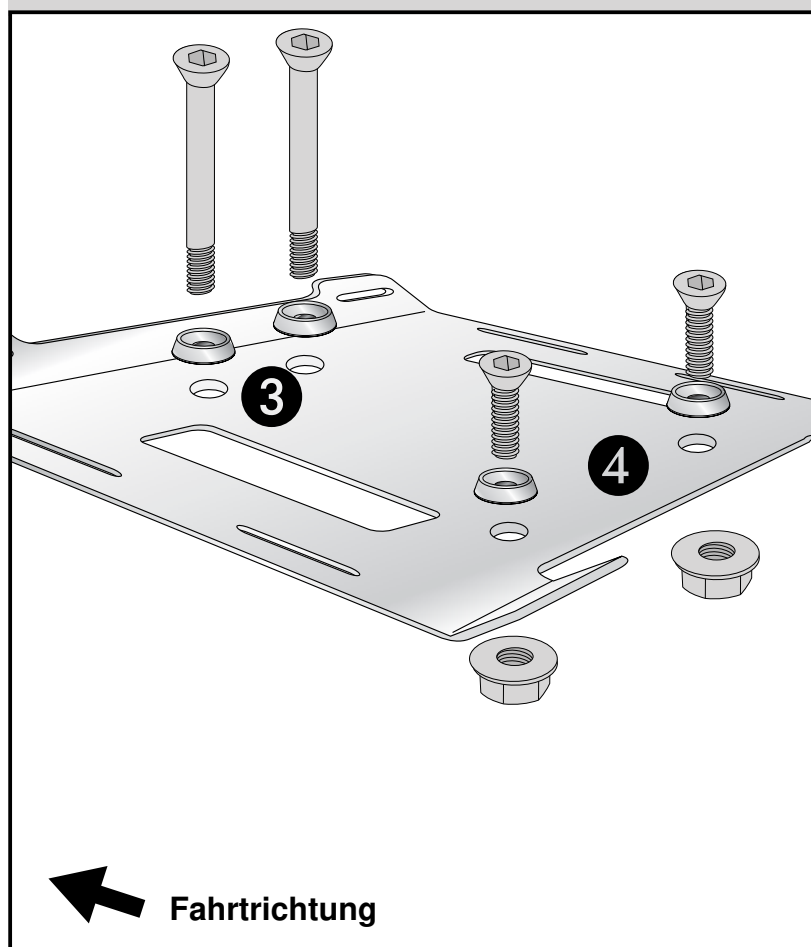
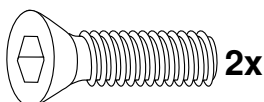
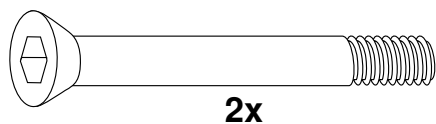

## Enlargement for rear carrier

**YAMAHA XT 1200 Z Super Tenere**  
up to date of manufacture 2013

**YAMAHA XT1200 Z Super Ténéré**  
**YAMAHA XT1200 ZE Super Ténéré**  
from date of manufacture 2014

Item-no.: 800.4531 silver

### Assembling instructions

Side cases  
Top cases  
luggage frames  
Lock it system  
Softbags  
Aluminium luggage  
Leather luggage  
Protection bars  
Center stands  
Chopper parts  
Quad parts  
Accessories



The kit includes the following parts:

Quant	item no.	description	Quant	item no.	description
1	700007804	enlargement	2	151.219	spacer Ø20xØ9x13mm
2	151.358	countersunk head allen screw M8x130	2	151.220	plastic washer Ø24xØ8,4x2mm
2	151.302	countersunk head allen screw M8x25	2	150.803	tensilock nut M8
4	151.302	countersunk washer ø8,4 x ø25mm			



**Control all screw connections after the assembling for tightness!**  
**Please notice our enclosed service information.**

Also available:

Side carrier Lock it (removable), Engine guard, Tank guard, Skid plate, Headlight grilles  
and much more accessories.



**Hepco & Becker GmbH**  
**An der Steinmauer 6**  
**D-66955 Pirmasens**  
**Germany**

**Tel.: +49 6331 - 1453 - 100**  
**Fax: +49 6331 - 1453 - 120**  
**eMail: [vertrieb@hepco-becker.de](mailto:vertrieb@hepco-becker.de)**  
**[www.hepco-becker.de](http://www.hepco-becker.de)**



## Enlargement for rear carrier

YAMAHA XT 1200 Z Super Tenere  
up to date of manufacture 2013

YAMAHA XT1200 Z Super Ténéré  
YAMAHA XT1200 ZE Super Ténéré  
from date of manufacture 2014

Item-no.: 800.4531 silver

### Assembling instructions

Side cases  
Top cases  
luggage frames  
Lock it system  
Softbags  
Aluminium luggage  
Leather luggage  
Protection bars  
Center stands  
Chopper parts  
Quad parts  
Accessories



#### Preparing front: ①

Unscrew original screw - they are obsolete.

Put spacers  $\text{Ø}20 \times \text{Ø}9 \times 13$  mm over the borings.

#### Preparing rear: ②

put plastic washers  $\text{Ø}24 \times \text{Ø}8,4 \times 2$  mm over the borings.



1

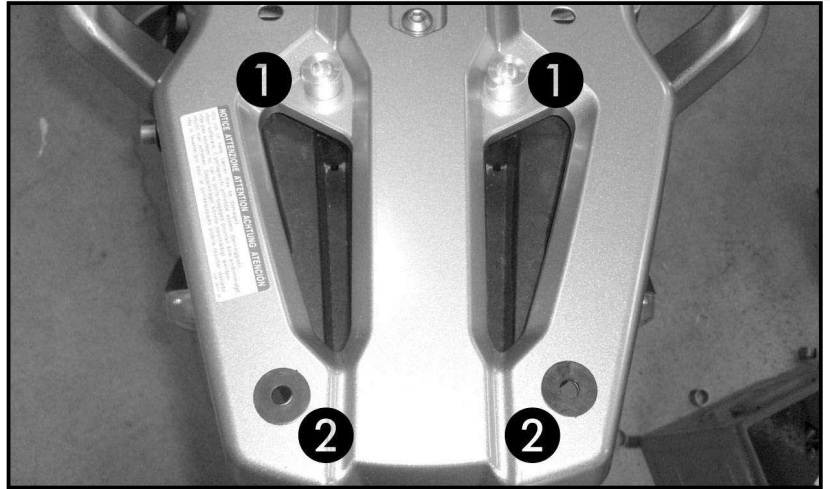

Fastening of the enlargement front: ③  
with countersunk head allen screw  
M8x130 and countersunk washers  $\text{Ø}8,4$ .

Fastening of the enlargement rear: ④  
with countersunk head allen screw M8x25  
and countersunk washers  $\text{Ø}8,4$ .  
Fix with tensilock nuts M8.

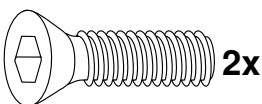
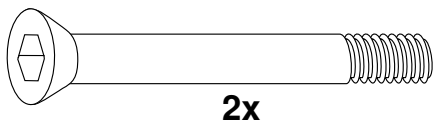

2

