

Minirack

KAWASAKI Versys
ab Bj.2010

Artikel-Nr.:
660.2510 01 01 schwarz

Montage

Seitenkoffer
Topcases
Gepäckträger
Lock it System
Softbags
Aluminiumkoffer
Lederkoffer
Schutzbügel
Hauptständer
Chopper-Parts
Quad-Parts
Accessoires



Der Bausatz enthält folgende Teile:

Stück	Bestellnr.	Bezeichnung	Stück	Bestellnr.	Bezeichnung
1	700008121	Alubrücke	4	150.799	selbstsichernde Muttern M6
1	700007271	Rohrstrebe links	4	150.923	Linsenkopfschrauben M8x30
1	700007272	Rohrstrebe rechts	2	150.937	Linsenkopfschrauben M8x16
1	700002979	Adapterlasche links	2	150.810	U-Scheiben ø8,4
1	700002980	Adapterlasche rechts	2	150.995	U-Scheiben ø8,4 x17x3 mm
4	150.763	Senkinbusschrauben M6 x 20	2	150.951	Karoseriescheiben ø8,4 xø24 x2mm
4	150.809	U-Scheiben ø6,4	2	150.805	Sprengring ø8,4
			4	151.069	Stahldistanzen ø14 x ø10x7 mm

Die Alubrücke ist nicht Topcase-tauglich.



**Nach der Montage alle Verschraubungen auf festen Sitz kontrollieren!
Bitte beachten Sie unsere beigefügten Serviceinformationen.**

Weiteres Zubehör:

650.2510 00 01 Kofferträger schwarz "Lock it System" (abnehmbar)
501.2510 00 01 Motorschutzbügel schwarz
630.2510 C-Bow Softtaschenhalter



Hepco & Becker GmbH
An der Steinmauer 6
D-66955 Pirmasens

Tel.: 06331 - 1453 - 100
Fax: 06331 - 1453 - 120
eMail: vertrieb@hepco-becker.de
www.hepco-becker.de

Minirack

KAWASAKI Versys
ab Bj.2010

Artikel-Nr.:
660.2510 01 01 schwarz

Seitenkoffer
Topcases
Gepäckträger
Lock it System
Softbags
Aluminiumkoffer
Lederkoffer
Schutzbügel
Hauptständer
Chopper-Parts
Quad-Parts
Accessoires



Montage

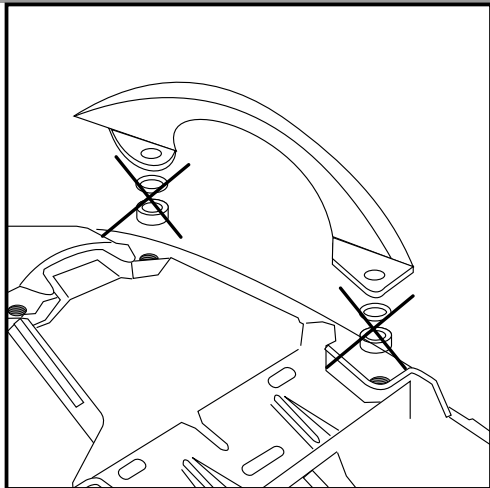

1

Vorbereitende Arbeiten:

Sitzbank und seitliche Verkleidungsteile (lackiert) demontieren.
Haltegriffe demontieren.

Die Blinker verbleiben in der Originalposition.

Die originalen Stahldistanzen aus den Haltepunkten der Haltegriffe demontieren, sie entfallen.
Ebenso entfallen die oberen Gummiringe

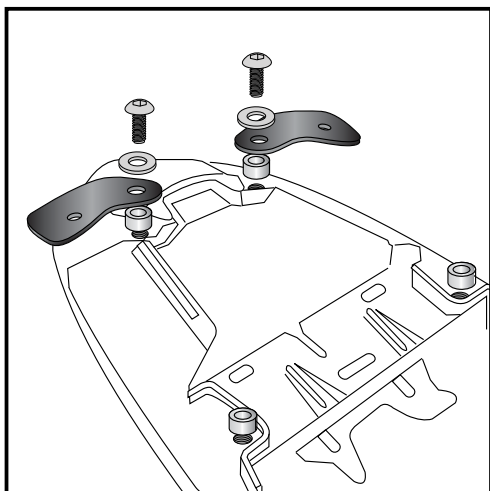

2

Montage der Adapterlaschen links und rechts:

Anstelle der Originaldistanzen die mitgelieferten Stahldistanzen $\varnothing 14 \times \varnothing 10 \times 7$ einsetzen.

Die Adapterlaschen werden an den hinteren Verschraubungspunkten mit den Linsenkopfschrauben M 8 x 30, Karoseriescheiben $\varnothing 8,4 \times \varnothing 24 \times 2$ mm verschraubt.

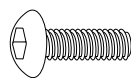

je 2x



4x

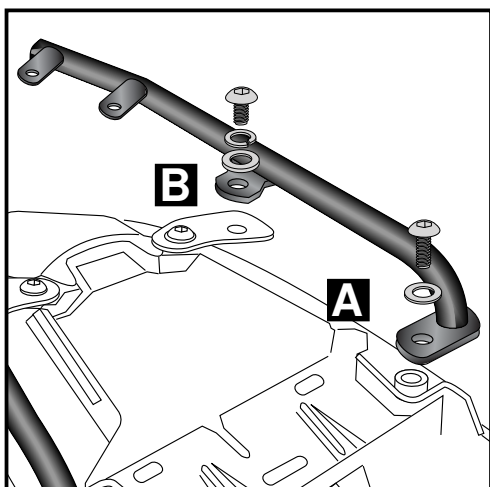

3

Montage der Rohrstreben links/rechts: _____

A Die Rohrstreben werden vorn mit den Linsenkopfschrauben M 8 x 30 und U-Scheiben $\varnothing 8,4$ verschraubt.

B Die hinteren Haltelaschen werden an dem Gewinde der Adapterlaschen mit den Linsenkopfschrauben 8 x 16, Spreng-ring $\varnothing 8,4$ und U-Scheiben $\varnothing 8,4 \times \varnothing 17 \times 3$ verschraubt.

Der Sprengring entfällt, wenn gleichzeitig der Lock-it-Kofferträger montiert wird.

A

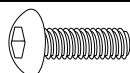

je 2x



B

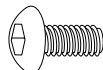

je 2x



Packende Ideen.

Minirack

KAWASAKI Versys
ab Bj.2010

Artikel-Nr.:
660.2510 01 01 schwarz

Montage

Seitenkoffer
Topcases
Gepäckträger
Lock it System
Softbags
Aluminiumkoffer
Lederkoffer
Schutzbügel
Hauptständer
Chopper-Parts
Quad-Parts
Accessoires



Montage der Alupalette:

Auf den zuvor montierten Rohrstreben mit den Senkinbusschrauben M6x20. Von unten mit den selbstsichernden Muttern M6 sowie U-Scheiben Ø6,4 verschrauben. Nun alle Teile festziehen.

4x

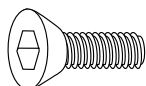

4x



4x



4

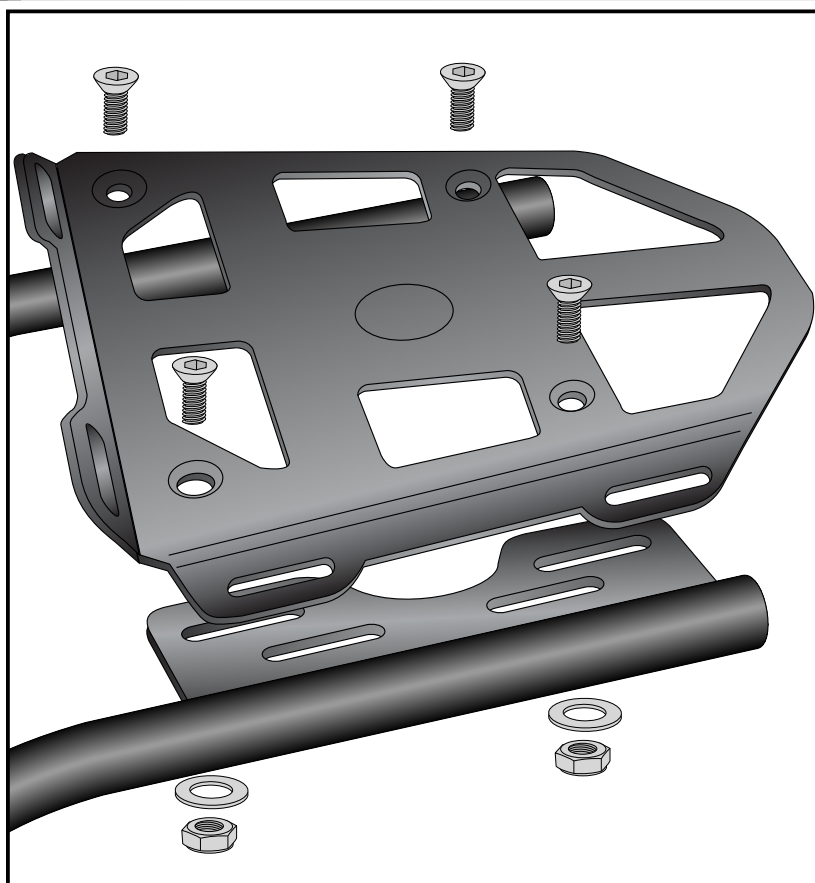

HINWEIS: an den zusätzlichen freien Bohrungen kann mit dem optional erhältlichen Lock it Hecktaschenhalter (Artikel-Nr. 506.100) unsere Sportrack Hecktasche (Artikel-Nr. 640.806) oder unser Daypack (Artikel-Nr. 640.803) sicher befestigt werden.

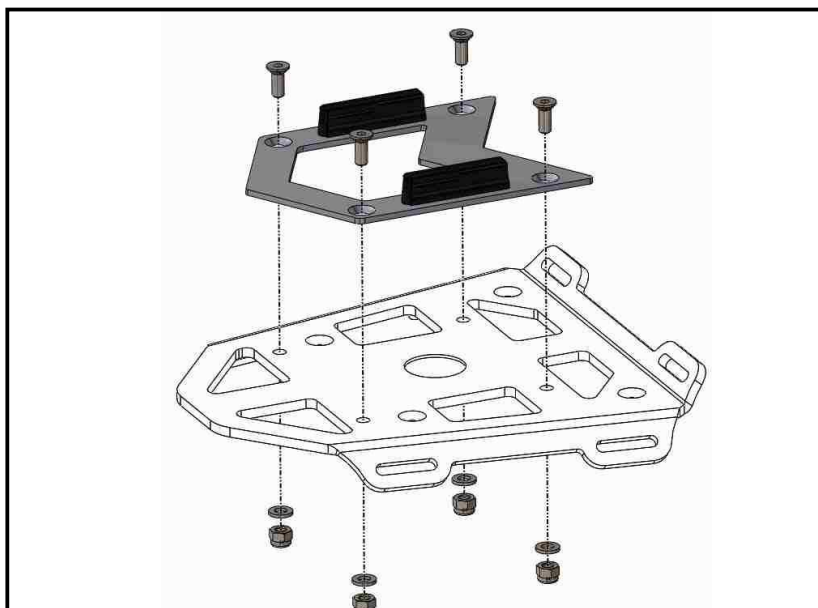

Minirack

KAWASAKI Versys
from date of manufacture 2010

Item - No.:
660.2510 01 01 black

Assembling instructions

Side cases
Top cases
luggage frames
Lock it system
Softbags
Aluminium luggage
Leather luggage
Protection bars
Center stands
Chopper parts
Quad parts
Accessories



The kit includes the following parts:

quant	item no.	description	quant	item no.	description
1	700008021	alu plate			
1	700007271	pipe strut left	4	150.799	self-lock nut M6
1	700007272	pipe strut right	4	150.923	fillister head screw M8x30
1	700002979	adapter left	2	150.937	fillister head screw M8x16
1	700002980	adapter right	2	150.810	washer ø8,4
4	150.763	countersunk allen screws M6 x 20	2	150.995	washer ø8,4 x17x3 mm
4	150.809	washer ø6,4	2	150.951	body washer ø8,4 xø24 x 2 mm
			2	150.805	lock ring ø8,4
			4	151.069	steel spacer ø14 x ø10x7 mm

The alu palette is not compatible with a topcase.



Control all screw connections after the assembling for tightness!
Please notice our enclosed service information.

Also available:

Item-no.: 650.2510 00 01

Item-no.: 501.2510 00 01

Item-no.: 630.2510

Side carrier, Lock it-System (removable), black

Engine guard, black

C-Bow carrier for softluggage



Hepco & Becker GmbH
An der Steinmauer 6
D-66955 Pirmasens

Tel.: +49 6331 - 1453 - 100
Fax: +49 6331 - 1453 - 120
eMail: vertrieb@hepco-becker.de
www.hepco-becker.de

Minirack

KAWASAKI Versys
from date of manufacture 2010

Item - No.:
660.2510 01 01 black

- Side cases
- Top cases
- luggage frames
- Lock it system
- Softbags
- Aluminium luggage
- Leather luggage
- Protection bars
- Center stands
- Chopper parts
- Quad parts
- Accessories



Assembling instructions

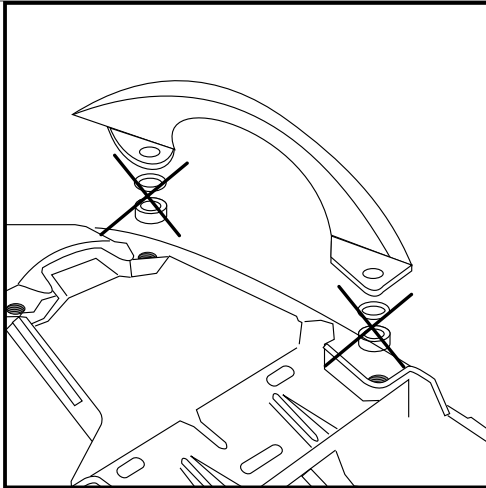

1

Preparing:

Unmount seat and handrails.
Unmount side sections of the rear cover.
Blinkers remain in their original position.

Not needed any more:
the original steel spacer from the handrails and rubber rings.

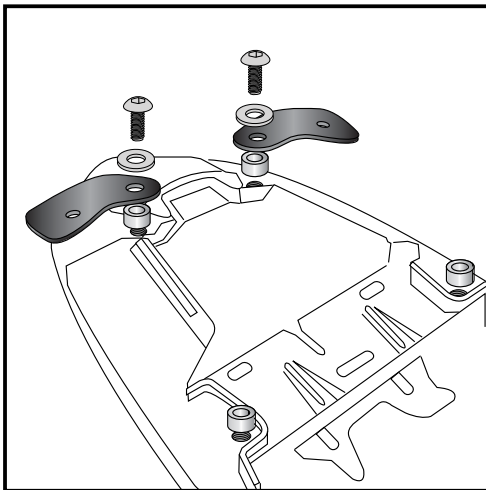

2

Fastening of the adapters left+right:

Use new steel spacer $\varnothing 14 \times \varnothing 10 \times 7$ instead of the original spacer.

The mounting struts will be fixed with filister head screw M 8 x 30 and body washer $\varnothing 8,4 \times \varnothing 24 \times 2$ mm.

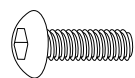

each 2x



4x

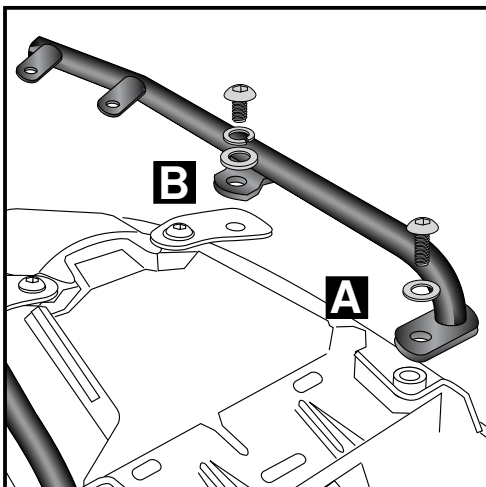

3

Fastening of the pipe strut left:

A at point A with filister head screw M 8 x 30 and washer $\varnothing 8,4$.

B at point B with filister head screw M8 x 16, lock ring $\varnothing 8,4$ and washer $\varnothing 8,4 \times \varnothing 17 \times 3$.

Lock ring is not used if assembling with the side carrier.

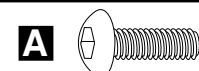

each 1x



each 1x



Luggage ideas.

Minirack

KAWASAKI Versys
from date of manufacture 2010

Item - No.:
660.2510 01 01 black



- Side cases
- Top cases
- luggage frames
- Lock it system
- Softbags
- Aluminium luggage
- Leather luggage
- Protection bars
- Center stands
- Chopper parts
- Quad parts
- Accessories

Assembling instructions

Fastening of the alu plate:

At the pipe struts with countersunk head screws M6x20. Secure it with self lock nuts M6 and washers Ø6,4

4

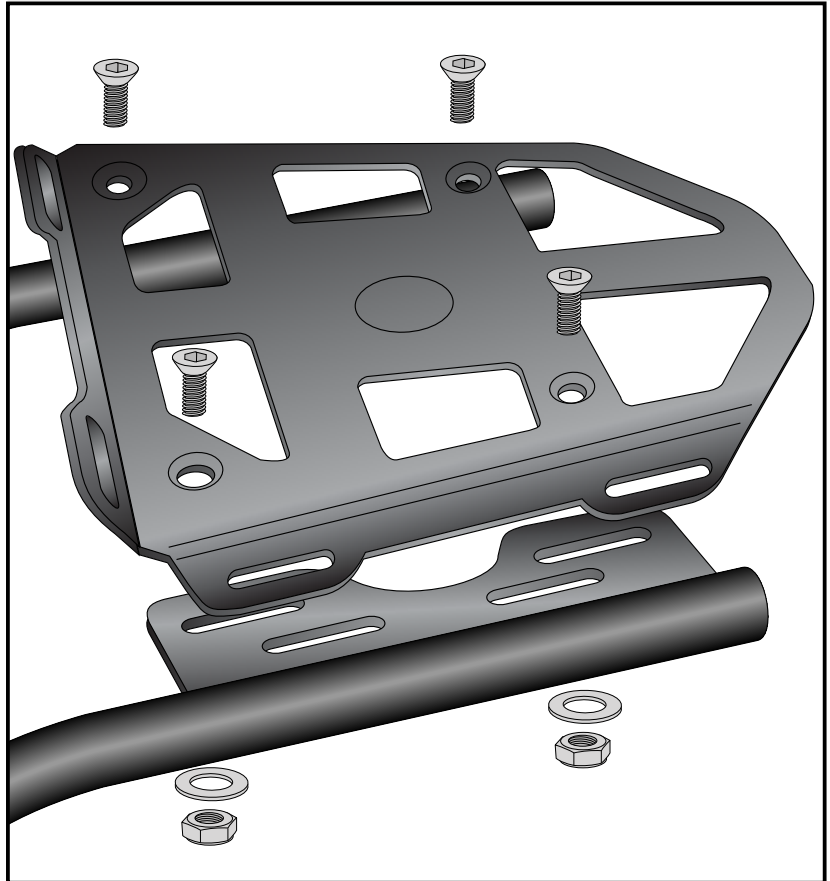

4x

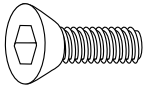

4x



4x



NOTE: with our optional lock it rear bag holder, (Item no. 506100) our Sportrack rear bag (item no. 640806) or our Daypack (Item no. 640803) can be securely fastened at the additional free holes.

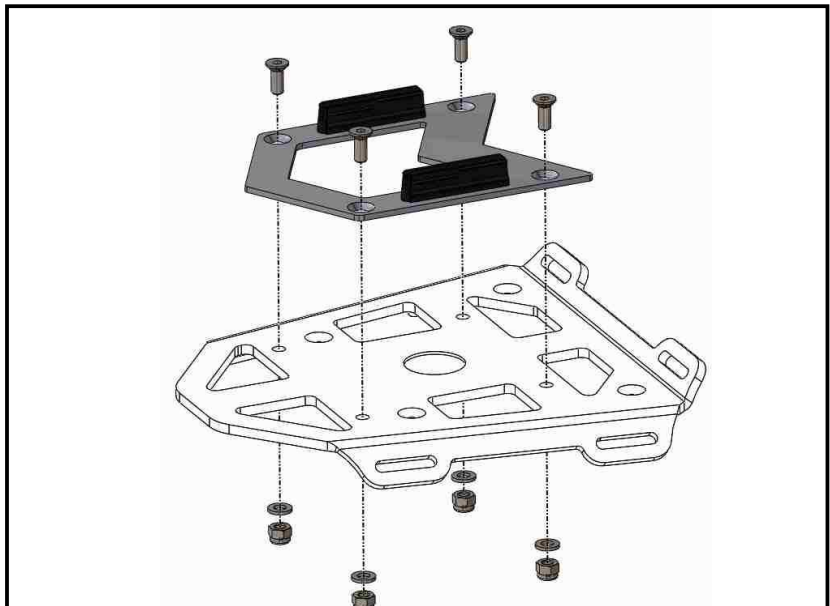

Luggage ideas.

3