



BMW F 650/700 GS
Artikel-Nr.: 810.652

BMW F 650/700 GS
Artikel-Nr.: 3005.018.301

BMW F 800 GS
Artikel-Nr.: 810.653

BMW F 800 GS
Artikel-Nr.: 3005.019.301

BMW F 800 GS Adventure
Artikel-Nr.: 810.667

BMW F 800 GS Adventure
Artikel-Nr.: 3005.033.301

Der Bausatz umfaßt die folgenden Teile:

Stück	Bestellnr.	Bezeichnung	Stück	Bestellnr.	Bezeichnung
1	705.524	Motorschutzplatte	1	151.224	Inbusschraube M8X110
1	705.525	Winkelhalterung	1	150.800	selbstsichernde Mutter M8
4	5218 065	Silentblock ø30 x 20mm Gewinde M8 x 20	4	150.810	U-Scheibe ø8,4
4	151.223	Alu-Distanz ø25Xø9X18mm	1	330.302	Emblem H&B ø30mm
4	151.145	Senkkopf-Inbusschraube M8X30			
2	150.937	Linsenkopfschraube M8X16			



Anzugsmomente des Motorradherstellers beachten!
Nach der Montage alle Verschraubungen auf festen Sitz kontrollieren!
Bitte beachten Sie unsere beigefügten Serviceinformationen.

Als weiteres Zubehör lieferbar:
Motorschutzbügel / Gepäckbrücke Alurack / Kofferträger Lock it / Lampenschutzgitter / Hauptständer



Hepco & Becker GmbH
An der Steinmauer 6
D-66955 Pirmasens
Tel.: 06331 - 1453 - 100
Fax: 06331 - 1453 - 120
eMail: vertrieb@hepco-becker.de
www.hepco-becker.de



Krauser GmbH
An der Steinmauer 6
D-66955 Pirmasens
Tel.: 06331 - 1453 - 250
Fax: 06331 - 1453 - 260
eMail: vertrieb@krauser.de
www.krauser.de



BMW F 650/700 GS
Artikel-Nr.: 810.652

BMW F 800 GS
Artikel-Nr.: 810.653

BMW F 800 GS Adventure
Artikel-Nr.: 810.667

BMW F 650/700 GS
Artikel-Nr.: 3005.018.301

BMW F 800 GS
Artikel-Nr.: 3005.019.301

BMW F 800 GS Adventure
Artikel-Nr.: 3005.033.301

Vorbereitung:
Original Unterfahrschutz entfernen,
er entfällt.

1

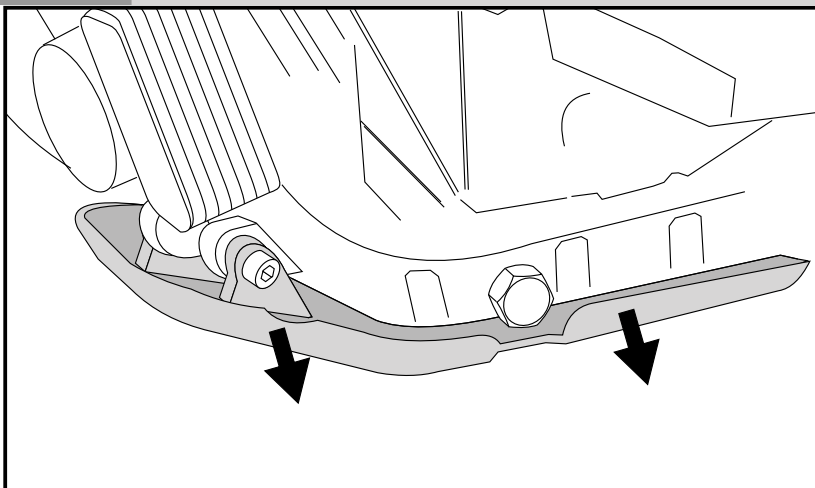

Original Silentblöcke aus der Ölwanne
ausschrauben, sie entfallen.

2

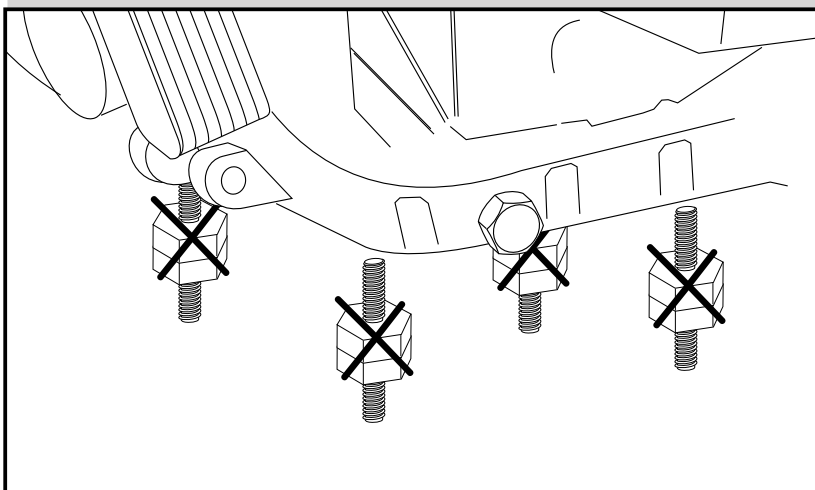

Anstelle der Original Silentblöcke die
mitgelieferten Silentblöcke M8 einsetzen.

3

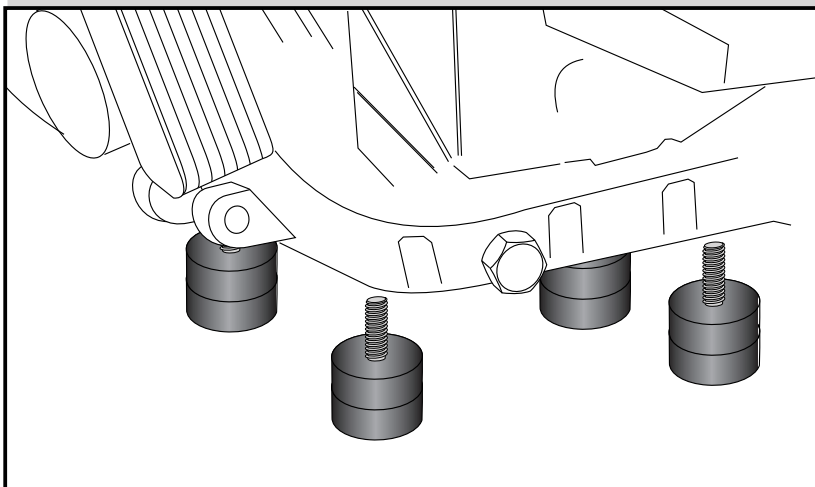

4x

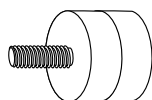



BMW F 650/700 GS
Artikel-Nr.: 810.652

BMW F 800 GS
Artikel-Nr.: 810.653

BMW F 800 GS Adventure
Artikel-Nr.: 810.667

BMW F 650/700 GS
Artikel-Nr.: 3005.018.301

BMW F 800 GS
Artikel-Nr.: 3005.019.301

BMW F 800 GS Adventure
Artikel-Nr.: 3005.033.301

4 Montage der Motorschutzplatte:
Zuerst die mitgelieferte Winkelhalterung an der vorderen Aufnahme montieren. Hierzu die mitgelieferte Inbusschraube M8X110, die Mutter M8 und die U-Scheiben ø8,4 verwenden.

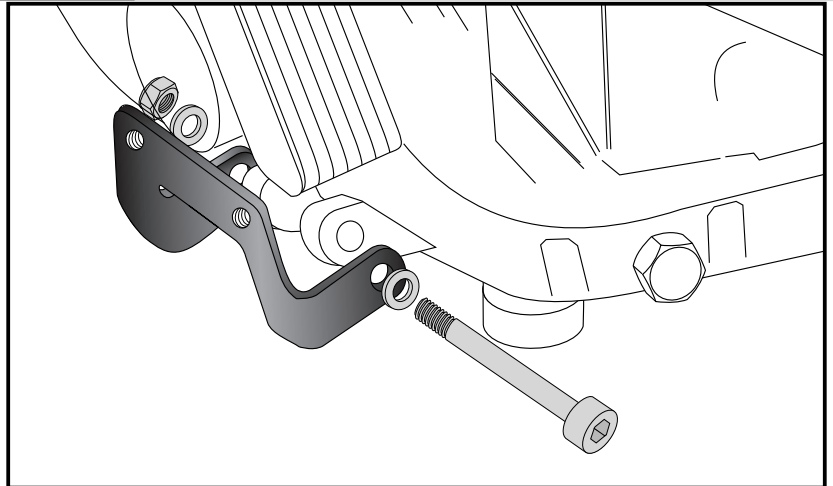
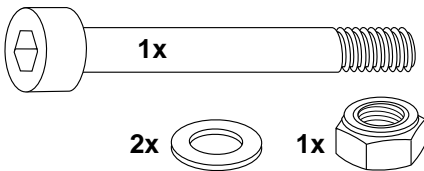

5 Montage der Motorschutzplatte:
Die 4 Alu-Distanzstücke ø25Xø9X18mm zusammen mit dem Unterfahrschutz auf die Silentblöcke schrauben. Hierzu die Senkkopf-Inbusschrauben M8X30 verwenden.

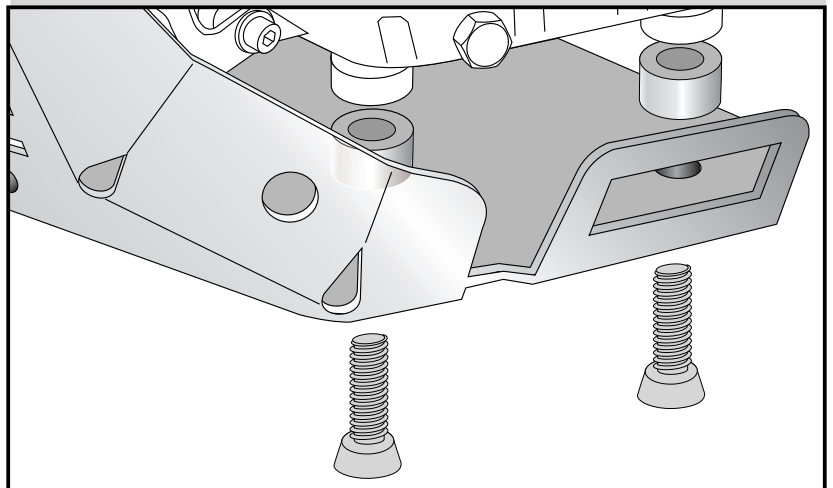
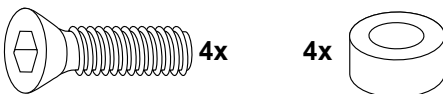

6 Montage der Motorschutzplatte:
zuletzt die Winkelhalterung mit dem Unterfahrschutz verschrauben. Hier die Linsenkopfschrauben M8X16 und die U-Scheiben ø8,4 verwenden.

Nun alle Verschraubungen fest anziehen.
Emblem anbringen.

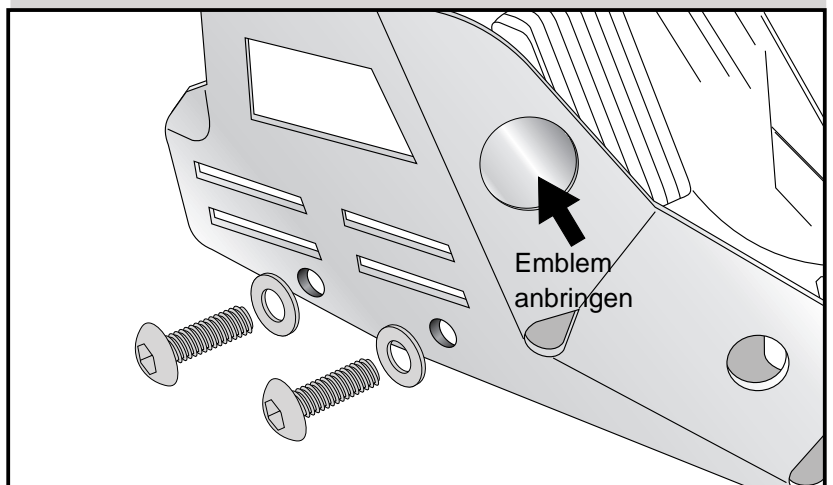



BMW F 650/700 GS
Item - No.: 810.652

BMW F 800 GS
Item - No.: 810.653

BMW F 800 GS Adventure
Item - No.: 810.667

BMW F 650/700 GS
Item - No.: 3005.018.301

BMW F 800 GS
Item - No.: 3005.019.301

BMW F 800 GS Adventure
Item - No.: 3005.033.301

The kit includes the following parts:

Quant	item no.	description
1	705.524	Engine protection plate
1	705.525	Holder
4	5218 065	silentblock M8 x 20
4	151.223	spacer ø25Xø9X18mm
4	151.145	countersunk head allen screw M8X30
2	150.937	filister head screw M8X16
1	151.224	allen screw M8X110
1	150.800	self-lock nut M8
4	150.810	washer ø8,4
1	330.302	emblem H&B ø30mm



Control all screw connections after the assembling for tightness!
Please notice our enclosed service information.

Also available:
Engine guard / Alu rack / Side carrier, removable / Headlight grille / Center stand



Hepco & Becker GmbH
An der Steinmauer 6
D-66955 Pirmasens
Tel.: +49 6331 - 1453 - 100
Fax: +49 6331 - 1453 - 120
eMail: vertrieb@hepco-becker.de
www.hepco-becker.de



Krauser GmbH
An der Steinmauer 6
D-66955 Pirmasens
Tel.: +49 6331 - 1453 - 250
Fax: +49 6331 - 1453 - 260
eMail: vertrieb@krauser.de
www.krauser.de



BMW F 650/700 GS
Item - No.: 810.652

BMW F 800 GS
Item - No.: 810.653

BMW F 800 GS Adventure
Item - No.: 810.667

BMW F 650/700 GS
Item - No.: 3005.018.301

BMW F 800 GS
Item - No.: 3005.019.301

BMW F 800 GS Adventure
Item - No.: 3005.033.301

Preparing:
Dismantle original engine protection,
it is obsolete.

1

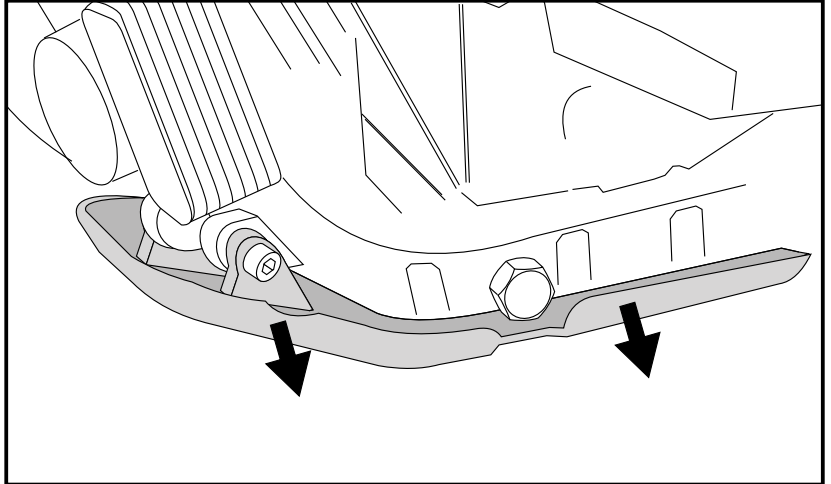

Dismantle original silent blocks,
they are obsolete.

2

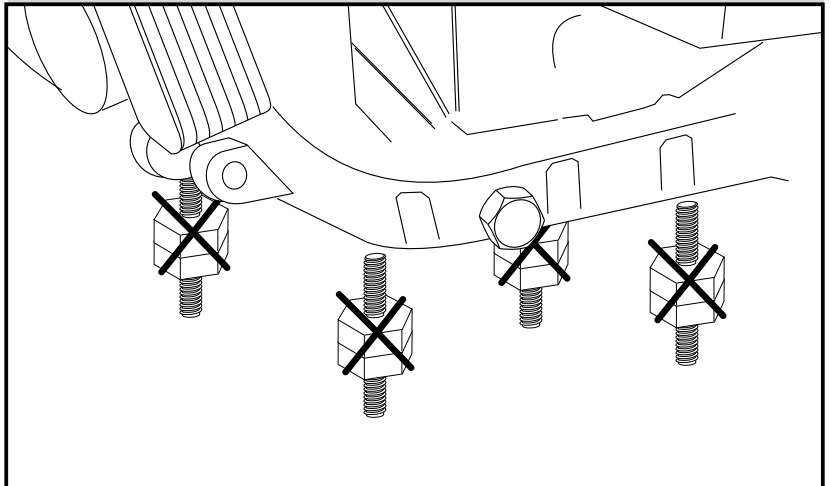

Instead of the original silent blocks use
the silent blocks M8 in this kit.

3

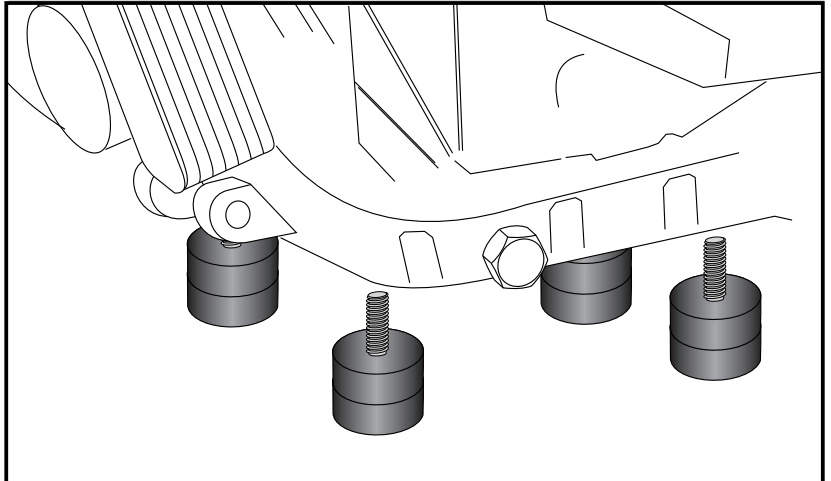

4x

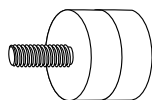



BMW F 650/700 GS
Item - No.: 810.652

BMW F 800 GS
Item - No.: 810.653

BMW F 800 GS Adventure
Item - No.: 810.667

BMW F 650/700 GS
Item - No.: 3005.018.301

BMW F 800 GS
Item - No.: 3005.019.301

BMW F 800 GS Adventure
Item - No.: 3005.033.301

4 Fastening of the engine protection plate:
First mount the holder with allen screw
M8X110, self-lock nut M8 and washers
ø8,4.

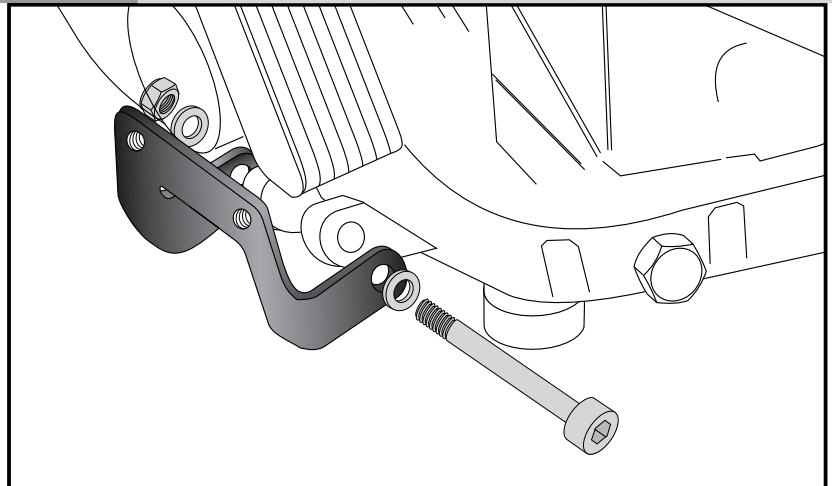
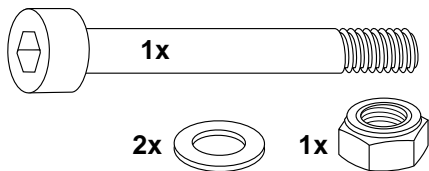

5 Fastening of the engine protection plate:
Fix the engine protection plate together
with spacers ø25Xø9X18mm to the
silent blocks.
Use countersunk head allen screws
M8X30.

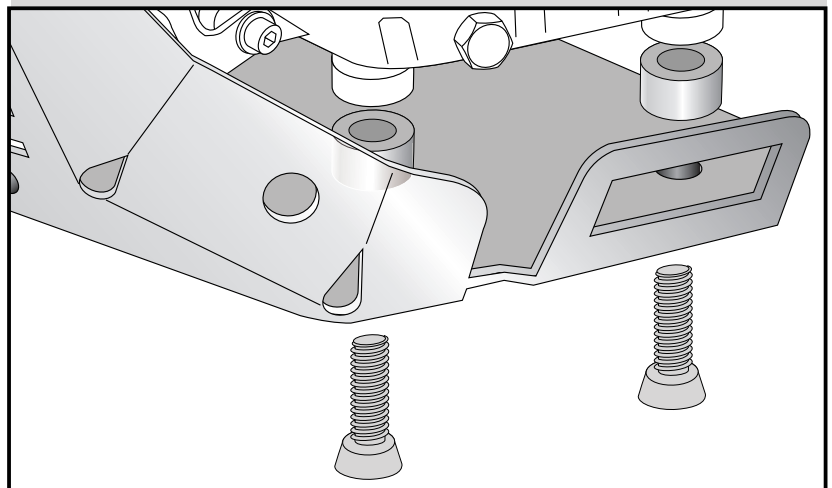
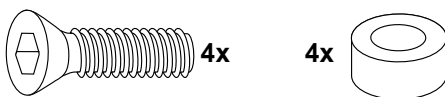

6 Fastening of the engine protection plate:
Fix the engine protection plate to the
holder.
Use filister head screws M8X16 with
washers ø6,4.
Stick emblem.

