



Motorschutzplatte

HONDA Crosstourer
HONDA Crosstourer DCT

Artikel-Nr.: 810.971

Motorschutzplatte

HONDA Crosstourer
HONDA Crosstourer DCT

Artikel-Nr.: 3001.056.301

Montage

Der Bausatz umfaßt die folgenden Teile:

| Stück | Bestellnr. | Bezeichnung |
|-------|------------|--------------------------|
| 1 | 700007947 | Motorschutzplatte |
| 1 | 700007948 | Haltestrebe vorne links |
| 1 | 700007949 | Haltestrebe vorne rechts |
| 1 | 700007950 | Halter hinten links |
| 1 | 700007951 | Halter hinten rechts |
| 2 | 150.905 | Linsenkopfschraube M6x20 |
| 6 | 151.258 | Senkkopfschraube M6x16 |
| 6 | 151.309 | Senkscheiben Ø6,4 x Ø18 |

| Stück | Bestellnr. | Bezeichnung |
|-------|------------|----------------------------------|
| 1 | 151.952 | Inbusschraube M10 x 1,25 x 60 mm |
| 2 | 150.930 | Inbusschraube M10 x 1,25 x 50 mm |
| 3 | 150.986 | U-Scheiben Ø10,5 |
| 2 | 151.076 | Aludistanzen Ø20xØ11x15mm |
| 1 | 151.026 | Aludistanz Ø18xØ11x30mm |
| 4 | 150.809 | U-Scheibe ø6,4 |
| 2 | 150.799 | Selbstsichernde Mutter M6 |
| 1 | 330.302 | Emblem H&B ø30mm |

**Nicht kompatibel mit dem Original
Honda-Motorschutzbügel.**

DCT-Modell

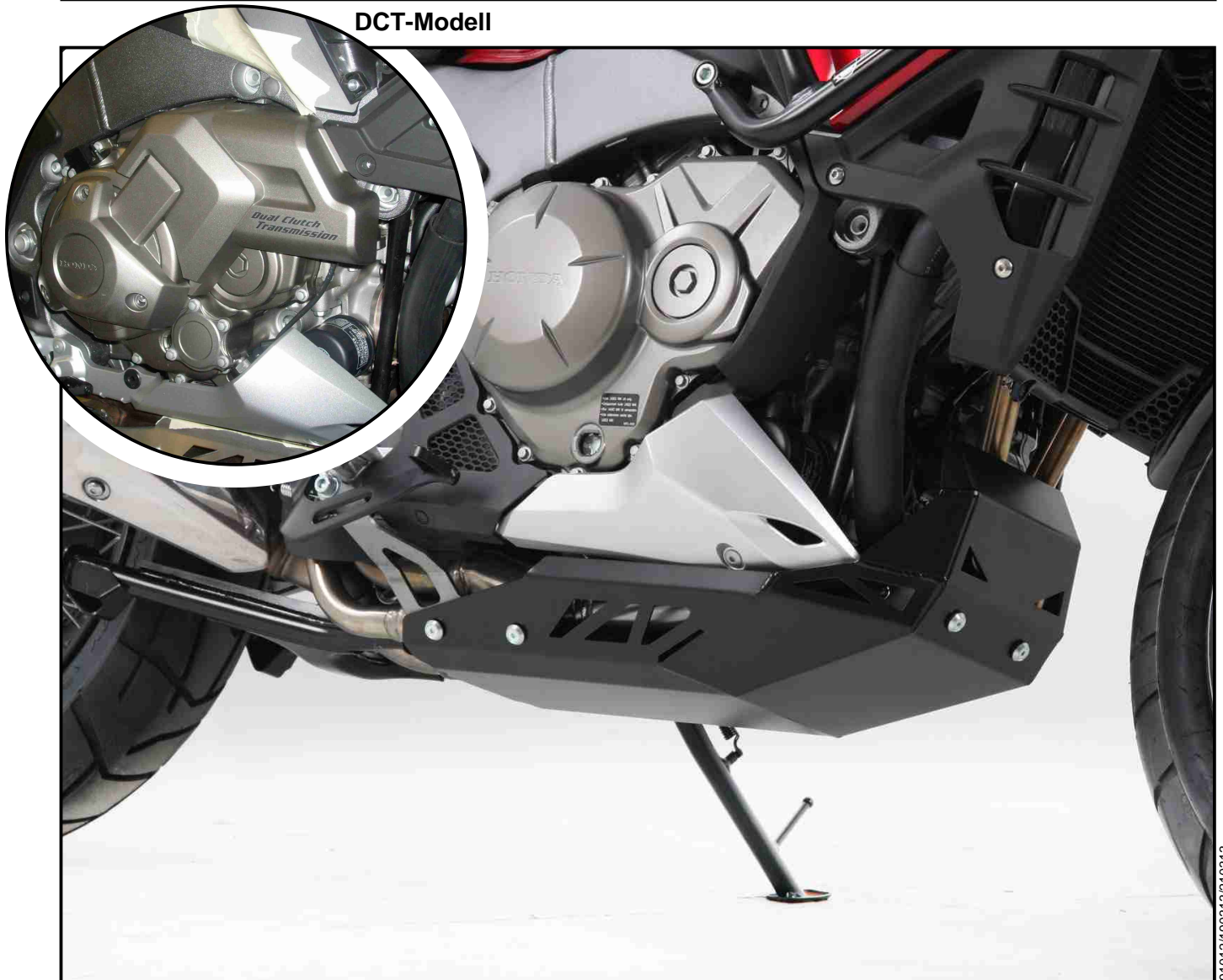



Motorschutzplatte

HONDA Crosstourer
HONDA Crosstourer DCT

Artikel-Nr.: 810.971

Motorschutzplatte

HONDA Crosstourer
HONDA Crosstourer DCT

Artikel-Nr.: 3001.056.301

Montage

Befestigung des Halteadapters hinten links:

Die Verschraubung erfolgt an der
Seitenständeraufnahme.
Original Schrauben entfallen.
Den Halteadapter mit den Inbus-
schrauben M10 x 1,25 x 50 mm sowie
U-Scheiben Ø10,5 montieren.
Zwischen Halter und Rahmenteil die
Aludistanzen Ø20xØ11x15mm fügen.

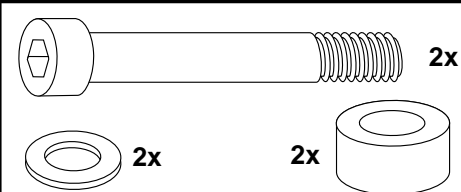

1

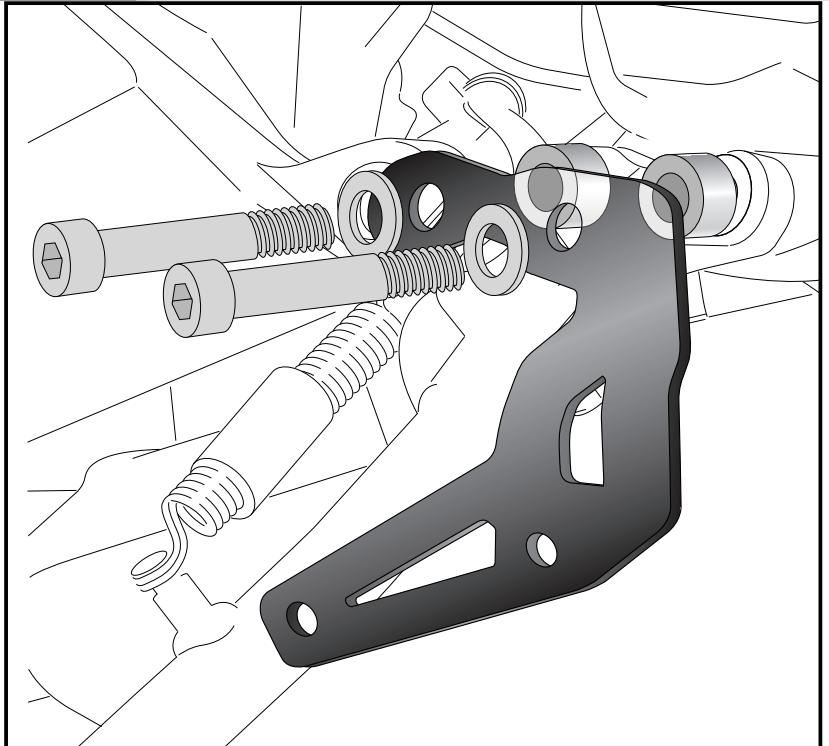

Befestigung des Halteadapters hinten rechts:

Die Verschraubung erfolgt an der
Fußrasteraufnahme.
Original Schraube unten entfällt.
Den Halteadapter mit der Inbus-
schraube M10 x 1,25 x 60 mm sowie U-
Scheibe Ø10,5 montieren.
Zwischen Halter und Rahmenteil die
Aludistanz Ø18xØ11x30 mm fügen.

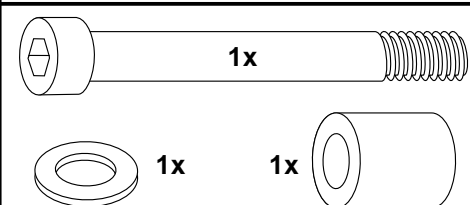

2

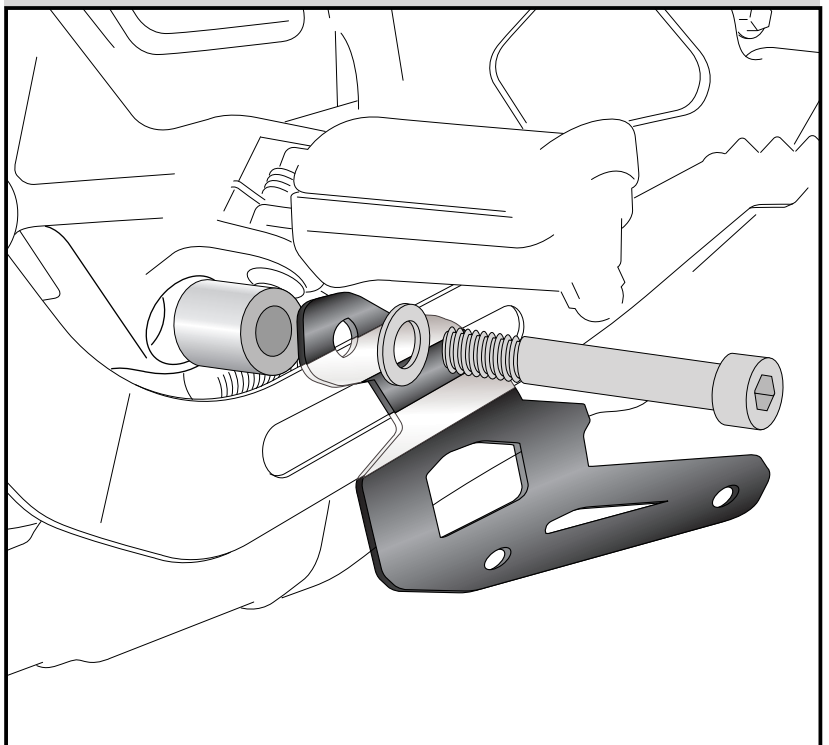



Motorschutzplatte

HONDA Crosstourer
HONDA Crosstourer DCT

Artikel-Nr.: 810.971

Motorschutzplatte

HONDA Crosstourer
HONDA Crosstourer DCT

Artikel-Nr.: 3001.056.301

Montage

Befestigung der Haltestrebe

vorne rechts und links:

Die Verschraubung erfolgt hinter der Motorhaltetasche.
Die Originalschraube herausdrehen.
Die hinter der Lasche befindliche Buchse entfernen - diese entfällt.
Die Haltestrebe wird anstelle der Buchse an der Motorhaltetasche mit der Originalschraube verschraubt.
Den Vorgang auf der linken Seite wiederholen.

HINWEIS für DCT-Modell:
damit die Originalschraube gelöst werden kann, muss der Deckel am Doppelkupplungsgetriebe demontiert werden.

Rechte Haltestrebe:

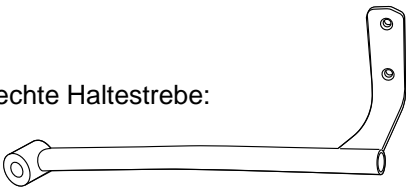

3

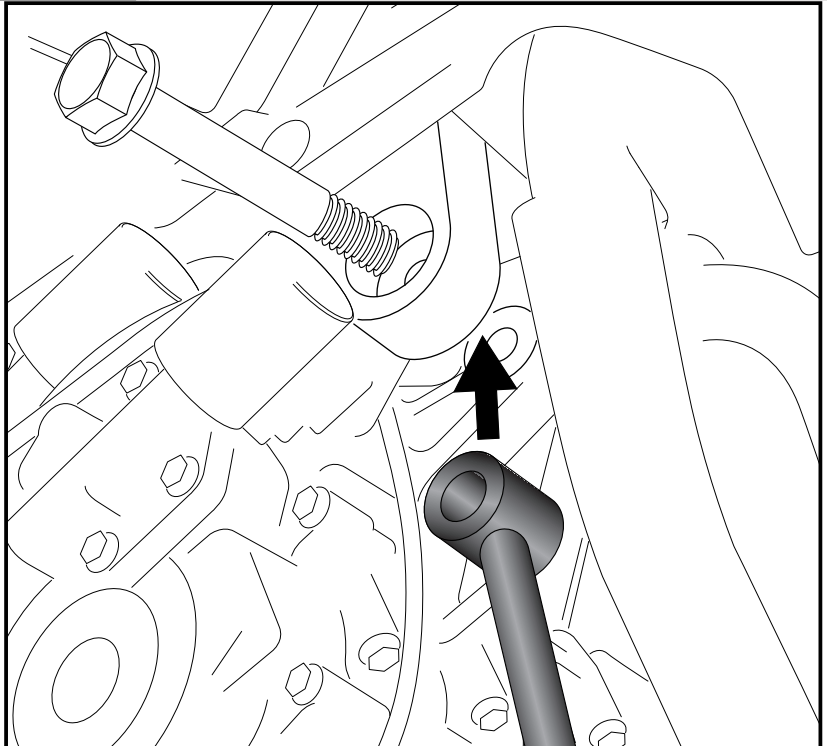

Verschraubung der Haltestreben miteinander vorne:

Die Haltestreben werden mit den Linsenkopfschrauben M6 x20, U-Scheiben ø6,4 und selbstsichernden Muttern M6 miteinander verschraubt.

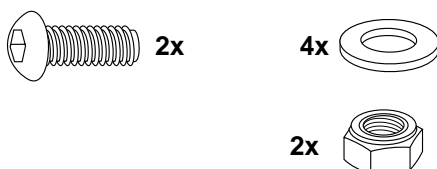

4

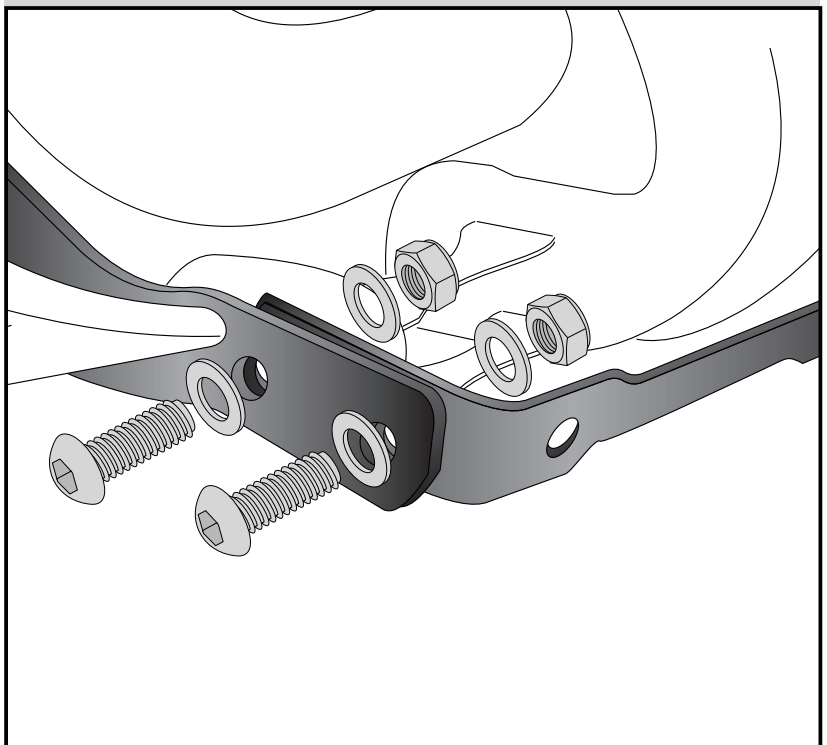



Motorschutzplatte

HONDA Crosstourer
HONDA Crosstourer DCT

Artikel-Nr.: 810.971

Motorschutzplatte

HONDA Crosstourer
HONDA Crosstourer DCT

Artikel-Nr.: 3001.056.301

Montage

5 Motorschutz vorne anbringen:

Motorschutz unter dem Motorrad positionieren.

Motorschutz an den Haltestreben vorne mit Senkkopfschrauben M6 x 16 und Senkscheiben $\varnothing 6,4 \times \varnothing 18\text{mm}$ verschrauben.

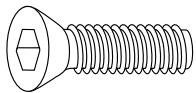

2x



2x

5

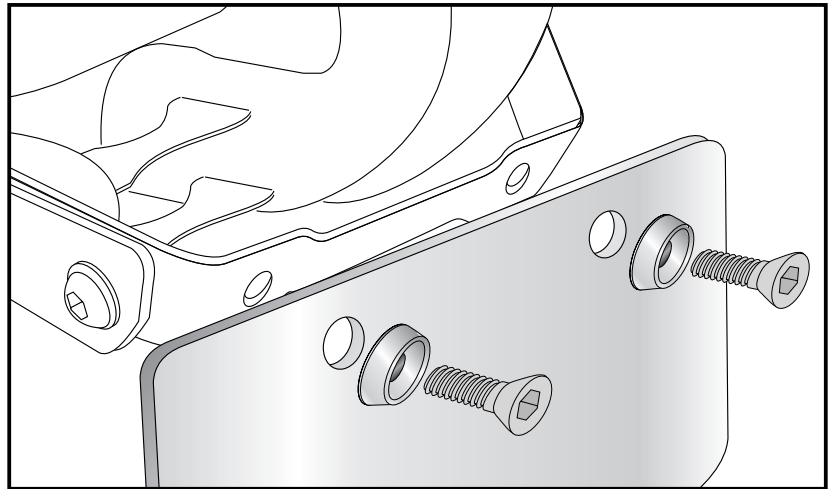

6 Motorschutz anbringen hinten:

Motorschutz am Halter mit Senkkopfschraube M6 x 16 und Senkscheibe $\varnothing 6,4 \times \varnothing 18\text{mm}$ befestigen.

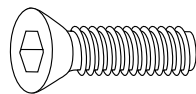

4x

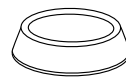

4x

6

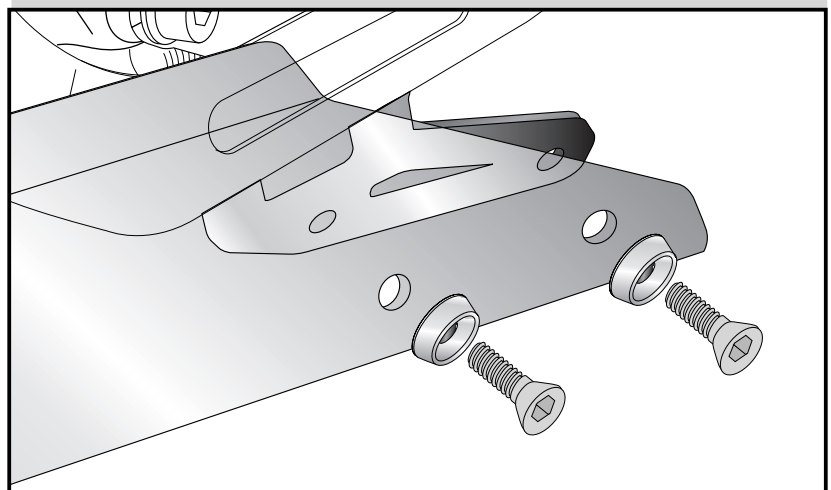

Anzugsmomente des Motorradherstellers beachten!
Nach der Montage alle Verschraubungen auf festen Sitz kontrollieren!
Bitte beachten Sie unsere beigefügten Serviceinformationen.

Als weiteres Zubehör lieferbar:

Lock it Kofferträger (abnehmbar)/Alurack Gepäckträger/C-Bow Halter für Softtaschen/Motorschutzbügel



Hepco & Becker GmbH
An der Steinmauer 6
D-66955 Pirmasens
Tel.: 06331 - 1453 - 100
Fax: 06331 - 1453 - 120
eMail: vertrieb@hepco-becker.de
www.hepco-becker.de



Krauser GmbH
An der Steinmauer 6
D-66955 Pirmasens
Tel.: 06331 - 1453 - 250
Fax: 06331 - 1453 - 260
eMail: vertrieb@krauser.de
www.krauser.de



Skid plate

HONDA Crosstourer
HONDA Crosstourer DCT

Item - No.: 810.971

Skid plate

HONDA Crosstourer
HONDA Crosstourer DCT

Item - No.: 3001.056.301

Assembling instructions

The kit includes the following parts:

| Quant | item no. | description |
|-------|-----------|-------------------------------|
| 1 | 700007947 | skid plate |
| 1 | 700007948 | adapter tube front left |
| 1 | 700007949 | adapter tube front right |
| 1 | 700007950 | adapter rear left |
| 1 | 700007951 | adapter rear right |
| 2 | 150.905 | filister head screw M6x20 |
| 6 | 151.258 | countersunk screw M6x16 |
| 6 | 151.309 | countersunk washer Ø6,4 x Ø18 |

| Quant | item no. | description |
|-------|----------|--------------------------------|
| 1 | 151.952 | allen screw M10 x 1,25 x 60 mm |
| 2 | 150.930 | allen screw M10 x 1,25 x 50 mm |
| 3 | 150.986 | washer Ø10,5 |
| 2 | 151.076 | alu spacer Ø20xØ11x15mm |
| 1 | 151.026 | alu spacer Ø18xØ11x30mm |
| 4 | 150.809 | washer ø6,4 |
| 2 | 150.799 | self-nock nut M6 |
| 1 | 330.302 | emblem H&B ø30mm |

**Not compatible with the original
Honda engine guard.**

DCT-Modell





Skid plate

HONDA Crosstourer
HONDA Crosstourer DCT

Item - No.: 810.971

Skid plate

HONDA Crosstourer
HONDA Crosstourer DCT

Item - No.: 3001.056.301

Assembling instructions

1 Fastening of the adapter rear left:
at the center stand bolting.
Original screw is obsolete.
Fix the adapter with the allen screw
M10 x 1,25 x 50 mm with washer Ø10,5.
Sandwich spacer Ø20xØ11x15 between
adapter and frame.

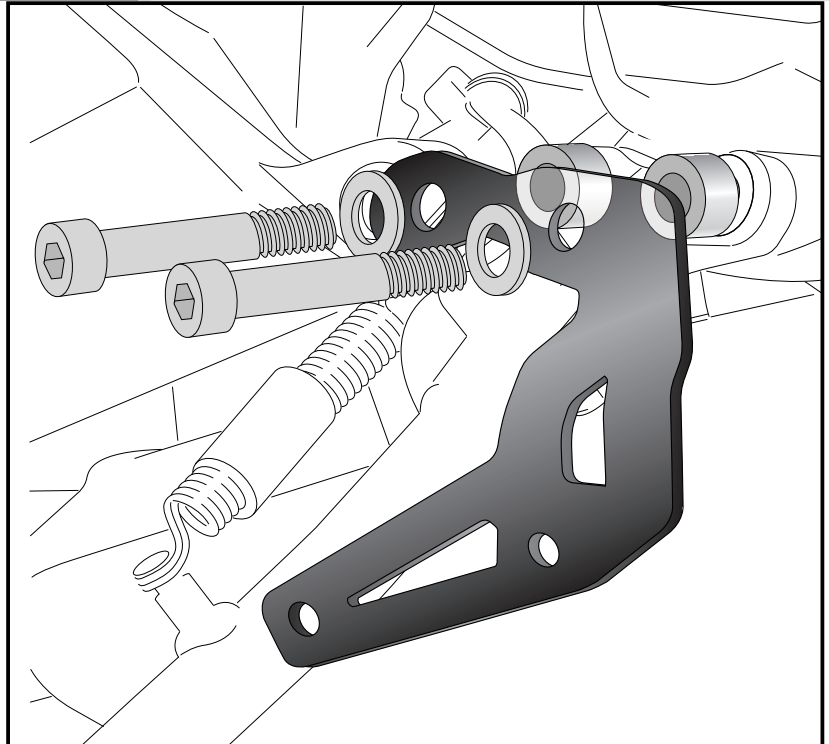
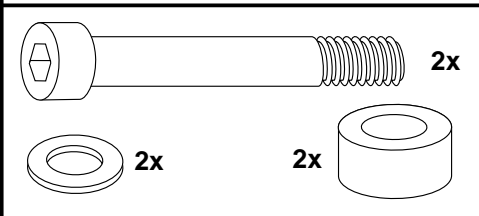

2 Fastening of the adapter rear right:
at the footrest bolting.
Original screw is obsolete.
Fix the adapter with the allen screw
M10 x 1,25 x 60 mm with washer Ø10,5.
Sandwich spacer Ø18xØ11x30 mm
between adapter and frame.

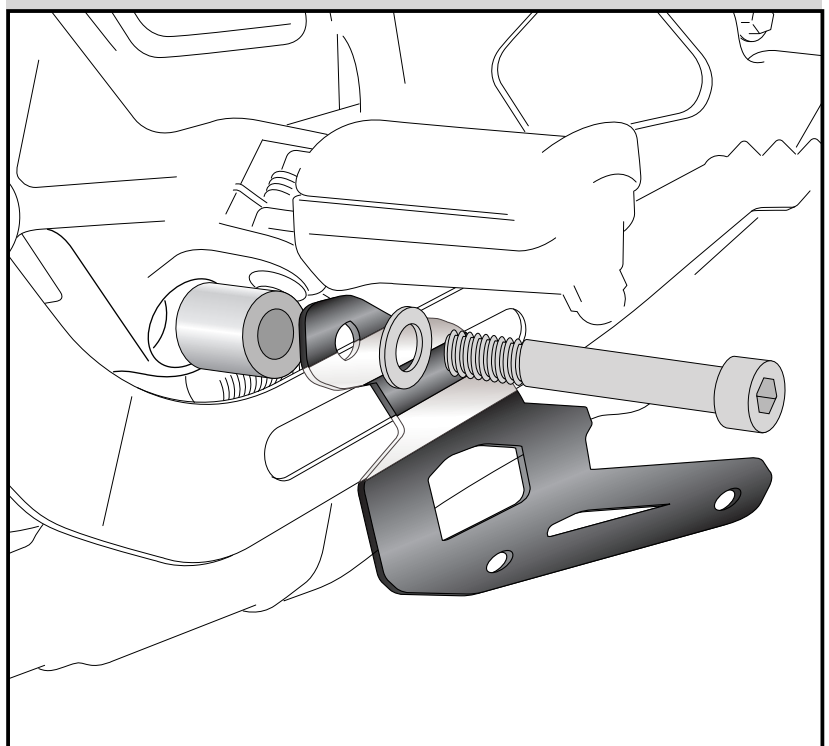
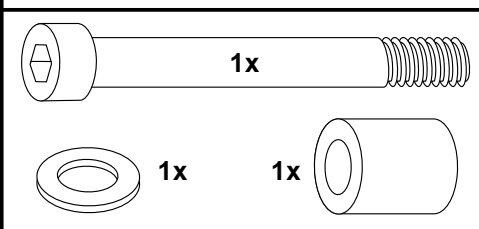



Skid plate

HONDA Crosstourer
HONDA Crosstourer DCT

Item - No.: 810.971

Skid plate

HONDA Crosstourer
HONDA Crosstourer DCT

Item - No.: 3001.056.301

Assembling instructions

3 Fastening of the adapter tube front right and left:

behind the engine retaining tab.
Dismantle original screw.
Dismantle original spacer behind the retaining tab - spacer is obsolete.

Fix the adapter tube instead of the spacer with the original screw.

Same procedure at the other side.

NOTE for DCT model:
to loose the original screw, the cover at the dual-clutch transmission must be removed.

adapter tube front right

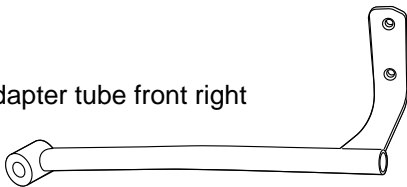

3

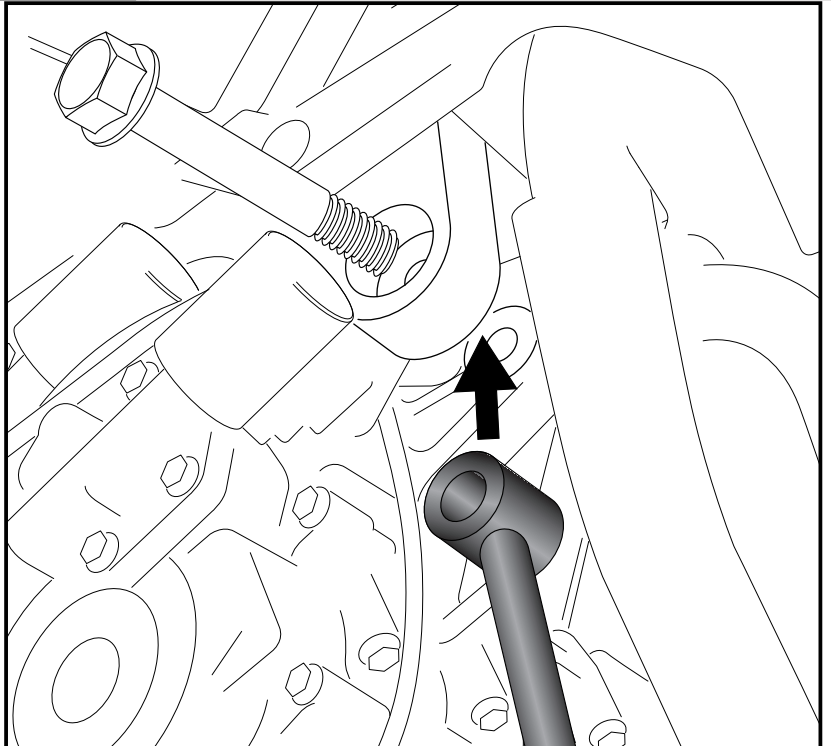

4 Connection of the adapter tubes front:

with filister head screws M6 x20, washers ø6,4 and self lock nuts M6 as shown.

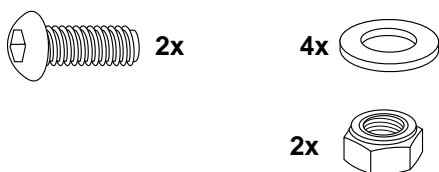

4

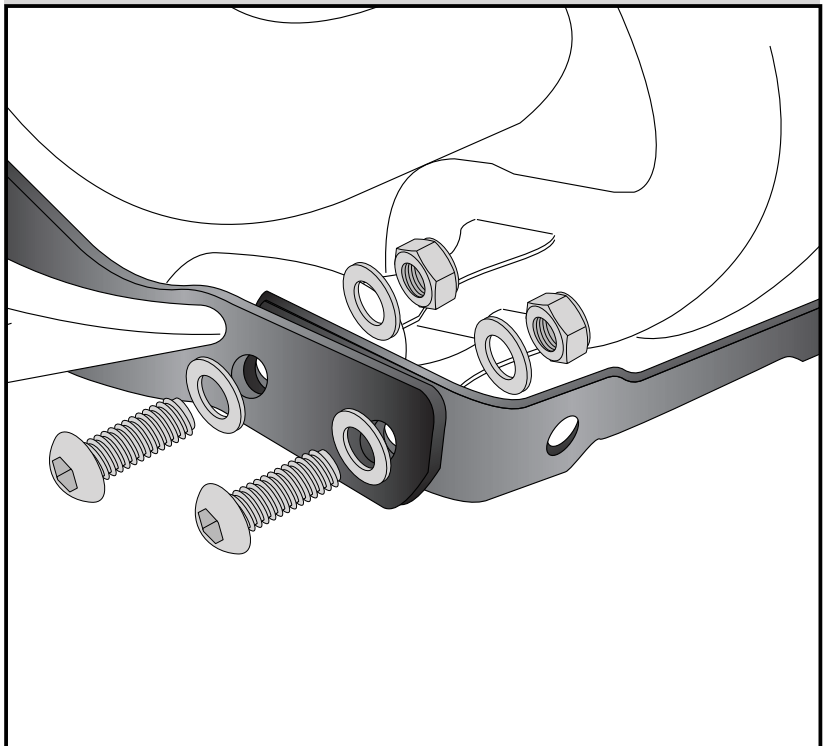



Skid plate

HONDA Crosstourer
HONDA Crosstourer DCT

Item - No.: 810.971

Skid plate

HONDA Crosstourer
HONDA Crosstourer DCT

Item - No.: 3001.056.301

Assembling instructions

Fastening of the engine protection front: **5**

Fix the plate with countersunk head allen screws M6 x16 mm and countersunk washer $\varnothing 8,4 \times \varnothing 25\text{mm}$.

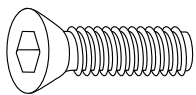

2x



2x

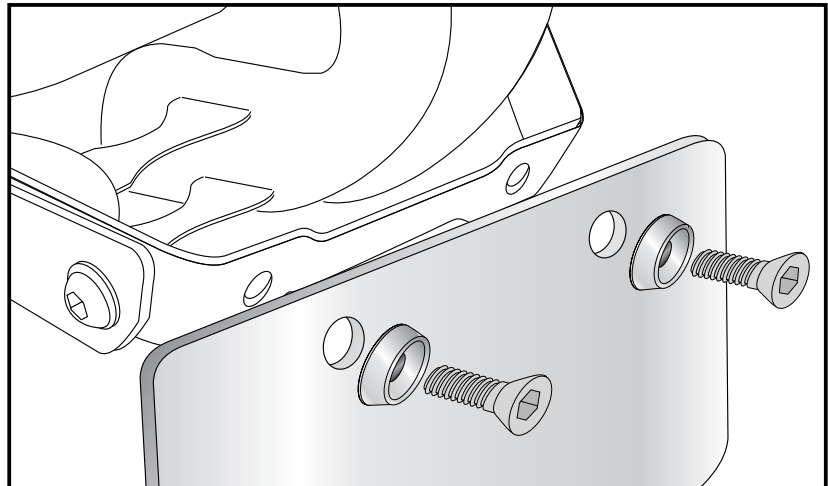

Fastening of the engine protection rear: **6**

Fix the plate with countersunk head allen screw M6 x 16mm and countersunk washer $\varnothing 6,4 \times \varnothing 18\text{mm}$.

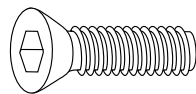

4x

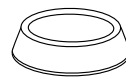

4x

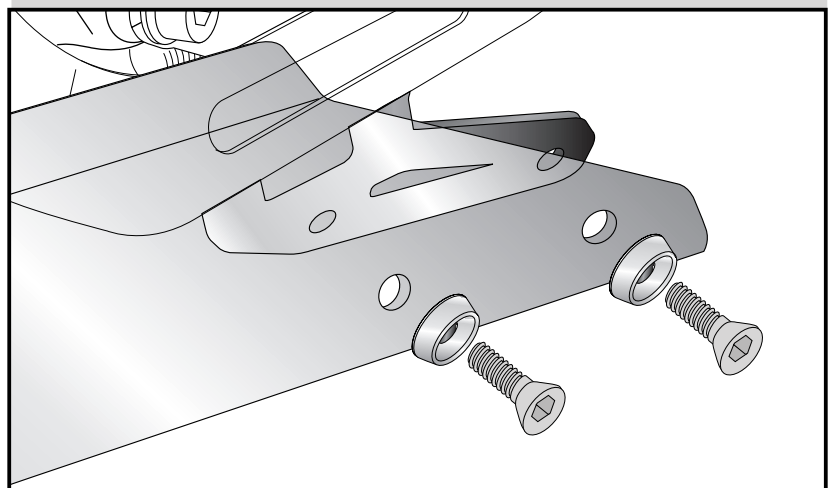

**Control all screw connections after the assembling for tightness!
Please notice our enclosed service information.**

Also available:

Lock it side carrier (removable)/Alurack rear rack/Engine guard/C-Bow holder for softbags



Hepco & Becker GmbH
An der Steinmauer 6
D-66955 Pirmasens
Germany
Tel.: 0049 6331 - 1453 - 100
Fax: 0049 6331 - 1453 - 120
eMail: vertrieb@hepco-becker.de
www.hepco-becker.de



Krauser GmbH
An der Steinmauer 6
D-66955 Pirmasens
Germany
Tel.: 0049 6331 - 1453 - 250
Fax: 0049 6331 - 1453 - 260
eMail: vertrieb@krauser.de
www.krauser.de