

PORTAVALIGIA SPECIFICO - SPECIFIC CASE HOLDER
 PORTE-VALISE SPECIFIQUE - SPEZIFISCHER KOFFER-TRÄGER
 PORTA-EQUIPAJE ESPECÍFICO

YAMAHA FJR1300 2006

ISTRUZIONI DI MONTAGGIO - MOUNTING INSTRUCTIONS
 INSTRUCTIONS DE MONTAGE - BAUANLEITUNG - INSTRUCCIONES DE MONTAJE

1



SUPPORTO
 SUPPORT
 HALTERUNG
 SOPORTE

Q.TY n.1

2



VITE TBEI M8x20mm
 SCREW M8x20mm
 VIS M8x20mm
 SCHRAUBE M8x20mm
 TORNILLO M8x20mm

Q.TY n.2

3



VITE TBEI M8x45mm
 SCREW M8x45mm
 VIS M8x45mm
 SCHRAUBE M8x45mm
 TORNILLO M8x45mm

Q.TY n.2

4



VITE TBEI M8x35mm
 SCREW M8x35mm
 VIS M8x35mm
 SCHRAUBE M8x35mm
 TORNILLO M8x35mm

Q.TY n.1

5



VITE TCEI M6x35mm
 SCREW
 VIS
 SCHRAUBE
 TORNILLO

Q.TY n.4

6



RONDELLA Ø6mm
 WASHER
 RONDELLE Ø6mm
 SCHEIBE Ø6mm
 ARANDELA Ø6mm

Q.TY n.4

7



RONDELLA f16x20mm
 WASHER
 RONDELLE
 SCHEIBE
 ARANDELA

Q.TY n.4

8



DISTANZIALE Ø22x21mm
 Foro Ø8,5mm, V596
 SPACER
 ENTRETROISE
 DISTANZSTÜCK
 DISTANCIADOR

Q.TY n.1

9



DISTANZIALE Ø22x31mm
 Foro Ø8,5mm, V516
 SPACER
 ENTRETROISE
 DISTANZSTÜCK
 DISTANCIADOR

Q.TY n.2

10



PIASTRA MONOKEY
 Z622M
 PLATE
 PLATINE
 PLATE
 PARRILLA

Q.TY n.1

11



COPRIFORO
 Z621
 BOLT CAP
 CACHE TROU
 STOPLOCK
 TAPA AGUJERO

Q.TY n.6

12



DADO A.B. M6
 BOLT M6
 ECROU M6
 MUTTER M6
 TUERCA M6

Q.TY n.4

13



GOMMA SAGOMATA
 6 Cm, Z1531
 RUBBER CUSHION
 CAOUTCHOUC PROFILE
 GEFORMTE GUMMI
 GOMA PROTECTORA

Q.TY n.1

14



RONDELLA Ø8x14mm
 WASHER Ø8x14mm
 RONDELLE Ø8x14mm
 SCHEIBE Ø8x14mm
 ARANDELA Ø8x14mm

Q.TY n.5

ATTENZIONE
 PESO MASSIMO SOPPORTABILE DAL PORTAPACCO
 10Kg.

WARNING
 MAX. LOADING OF THE CARRIER 10Kg.(21lbs)

ATTENTION
 CHARGE MAXIMALE 10Kg.

ACHTUNG
 MAXIMALE BELASTUNG DES TRÄGERS 10Kg.

¡ATENCIÓN!
 CARGA MÁXIMA AUTORIZADA 10Kg.

A

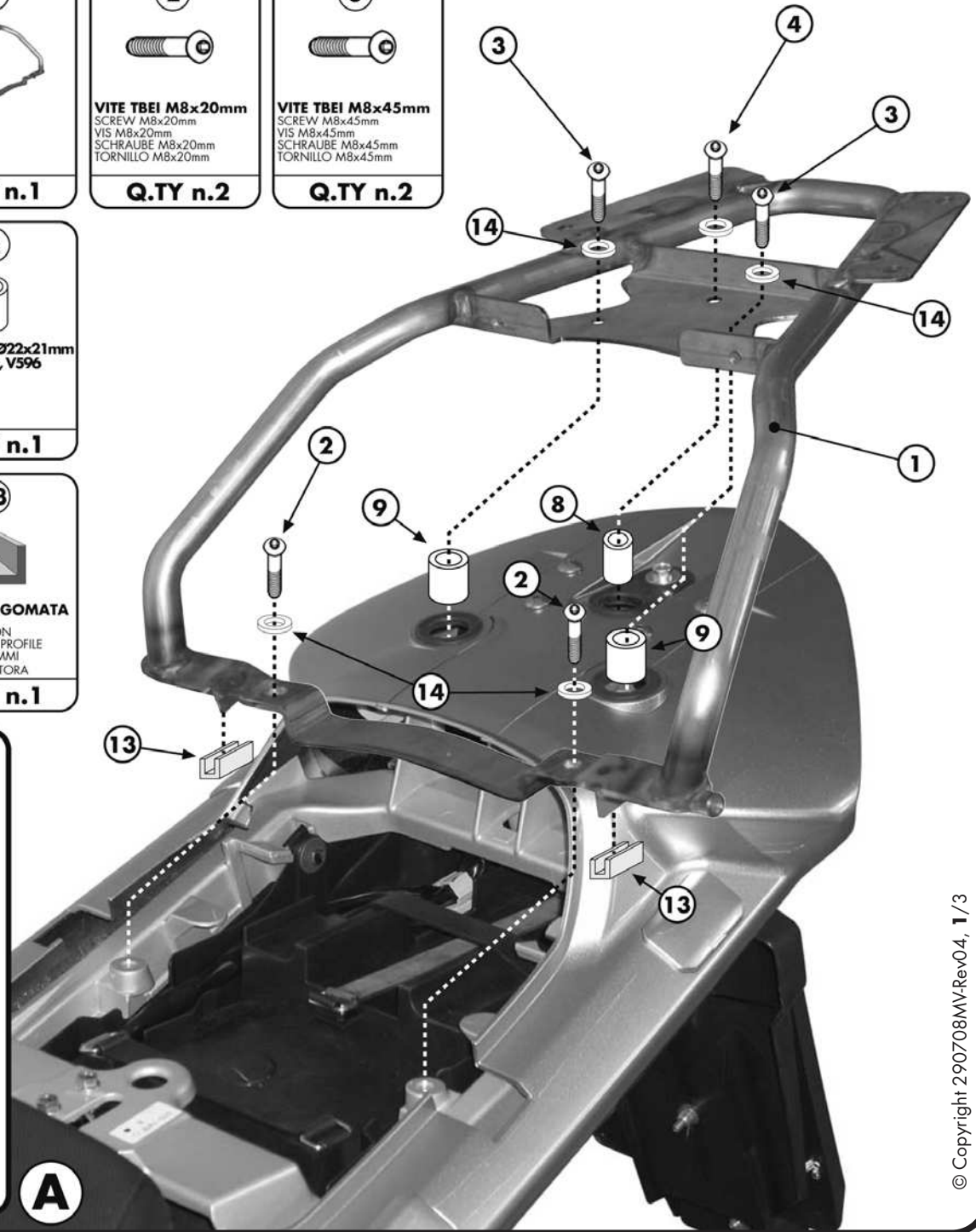

PORTAVALIGIA SPECIFICO - SPECIFIC CASE HOLDER
 PORTE-VALISE SPECIFIQUE - SPEZIFISCHER KOFFER-TRÄGER
 PORTA-EQUIPAJE ESPECIFICO

YAMAHA FJR1300 2006

ISTRUZIONI DI MONTAGGIO - MOUNTING INSTRUCTIONS
 INSTRUCTIONS DE MONTAGE - BAUANLEITUNG - INSTRUCCIONES DE MONTAJE

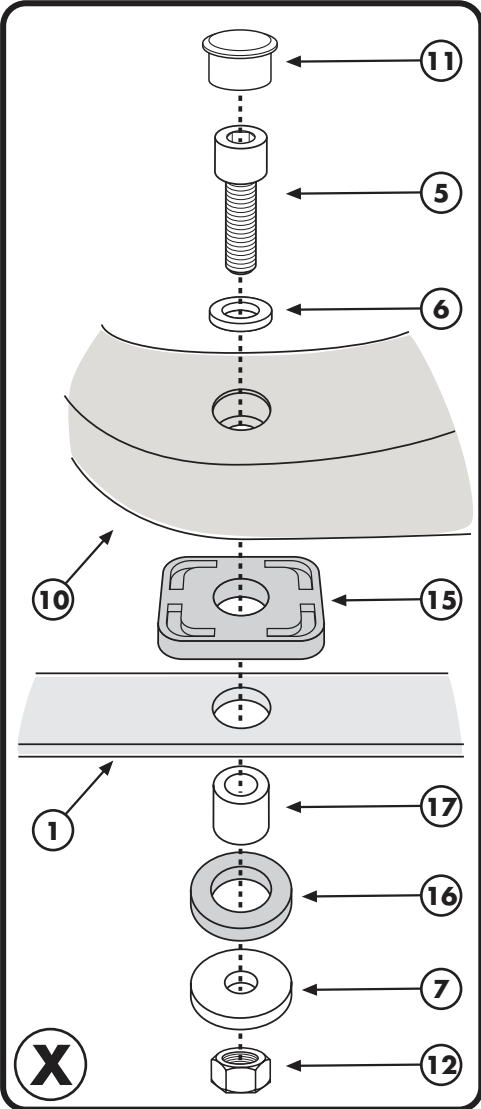

15

GOMMINO
 Z1822
 RUBBER
 CAOUTCHOUC
 GUMMI
 GOMA

Q.TY n.4

16

RONDELLA IN GOMMA
 Z1823
 RUBBER WASHER
 RONDELLE EN GOMME
 GUMMISCHIBE
 ARANDELA DE GOMA

Q.TY n.4

17

DISTANZIALE $\phi 11 \times 11 \text{mm}$
 foro $\phi 6,5 \text{mm}$
 V687
 SPACER
 ENTRETÔISE
 DISTANZSTÜCK
 DISTANCIADOR

Q.TY n. 4

B

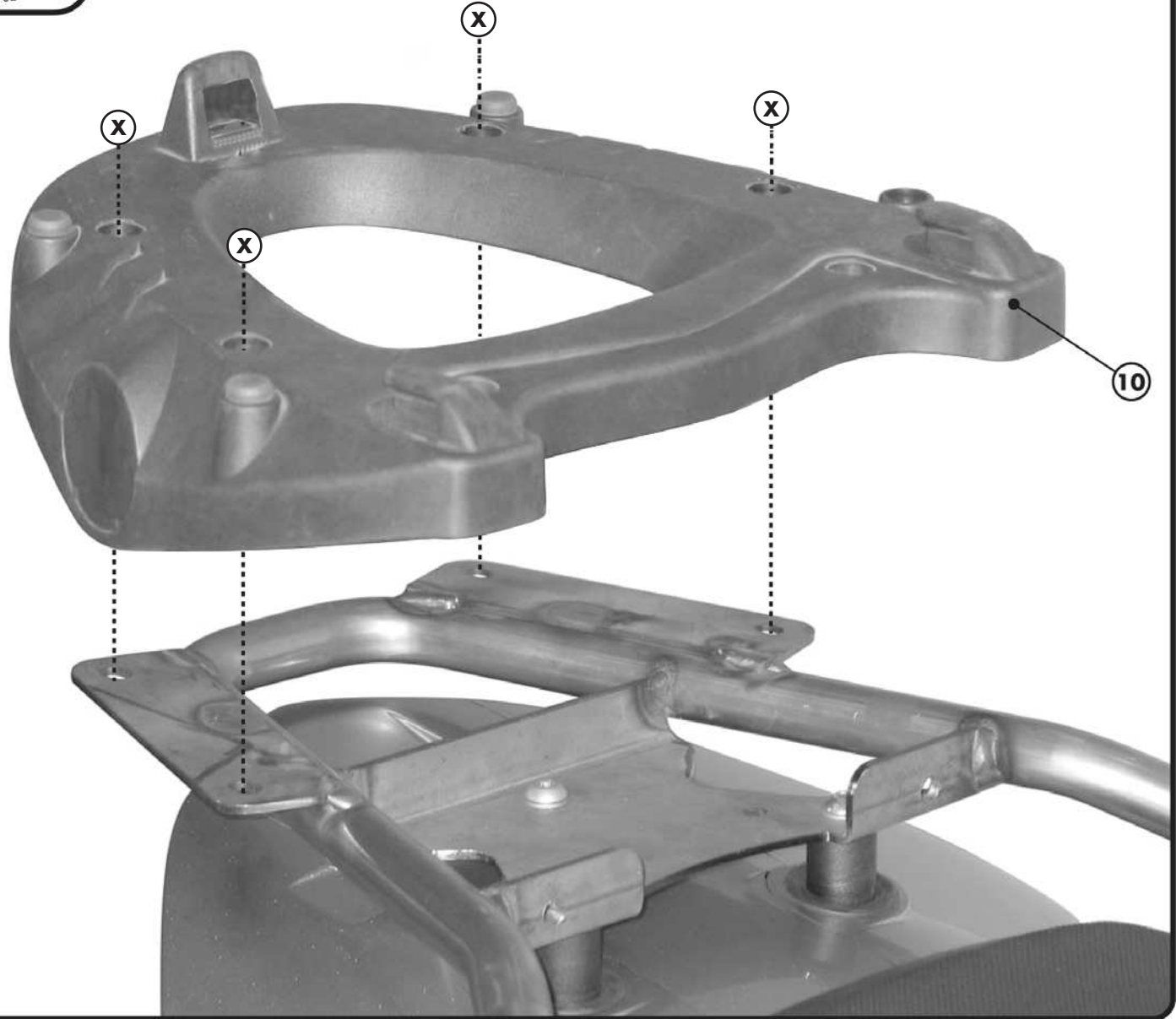

PORTAVALIGIA SPECIFICO - SPECIFIC CASE HOLDER
 PORTE-VALISE SPECIFIQUE - SPEZIFISCHER KOFFER-TRÄGER
 PORTA-EQUIPAJE ESPECIFICO

YAMAHA FJR1300 2006

ISTRUZIONI DI MONTAGGIO - MOUNTING INSTRUCTIONS
 INSTRUCTIONS DE MONTAGE - BAUANLEITUNG - INSTRUCCIONES DE MONTAJE

I ISTRUZIONI DI MONTAGGIO

1. SMONTARE IL MANIGLIONE ORIGINALE;
2. MONTARE IL PORTAVALIGIA POSTERIORE COME INDICATO IN FOTOGRAFIA A E B; FARE ATTENZIONE AL POSIZIONAMENTO DELLE PROTEZIONI IN GOMMA N°13, COME INDICATO IN FOTOGRAFIA A;
3. ULTIMARE IL MONTAGGIO VERIFICANDO CHE TUTTE LE VITI SIANO SERRATE BENE E CHE IL TAPPO ANTIFURTO ED I GOMMINI SIANO MONTATI CORRETTAMENTE SULLA PIASTRA.

GB MOUNTING INSTRUCTIONS

1. REMOVE THE ORIGINAL GRAB RAILS;
2. MOUNT THE TOP-CASE CARRIER AS SHOWN IN PICTURES A AND B; PAYING PARTICULAR ATTENTION IN ORDER TO PLACE THE RUBBER PROTECTION N°13 CORRECTLY AS SHOWN IN PICTURE A;
3. LASTLY CHECK THAT ALL SCREWS HAVE BEEN TIGHTENED AND THAT THE RUBBERS AND THE ANTI-THEFT CAP HAVE BEEN CORRECTLY POSITIONED ON THE PLATE.

F INSTRUCTIONS DE MONTAGE

1. DEMONTER LA POIGNEE D'ORIGINE ;
2. MONTER LE SUPPORT TOP CASE COMME INDIQUE EN PHOTOS A ET B ; FAIRE ATTENTION AU POSITIONNEMENT DES PROTECTIONS EN GOMME N°13 COMME MONTRE EN PHOTO A ;
3. TERMINER LE MONTAGE EN CONTROLANT LE BON SERRAGE DE TOUTES LES VIS AINSI QUE LA MISE EN PLACE DU BOUCHON ANTIVOL ET DES SILENT BLOCS SUR LA PLATINE.

D BAUANLEITUNG

1. ENTFERNEN SIE DEN ORIGINAL HANDGRIFF;
2. MONTIEREN SIE DEN KOFFERTRÄGER WIE IN DEN BILDERN A UND B BESCHRIEBEN; POSITIONIEREN SIE DIE GUMMISCHUTZE NR. 13 WIE IM BILD A BESCHRIEBEN;
3. ZULETZT ÜBERPRÜFEN SIE, DASS ALLE SCHRAUBEN FESTGEZOGEN WURDEN UND DASS DIE GUMMISTÜCKE SOWIE DIE DIEBSTAHSICHERUNG AUF DER PLATTE KORREKT POSITIONIERT WURDEN.

ES

INSTRUCCIONES DE MONTAJE

1. DESMONTAR EL ASA ORIGINAL
2. MONTAR EL PORTAEQUIPAJE POSTERIOR TAL Y COMO SE INDICA EN LA FOTOGRAFÍA A Y B; PRESTAR ESPECIAL ATENCIÓN EN EL POSICIONAMIENTO DE LAS GOMAS PROTECTORAS (N°13), TAL Y COMO SE MUESTRA EN LA FOTOGRAFÍA A.
3. ULTIMAR EL MONTAJE VERIFICANDO QUE TODOS LOS TORNILLOS ESTAN BIEN APRETADOS Y QUE EL TAPON ANTIRROBO Y LAS GOMAS ESTAN MONTADAS CORRECTAMENTE EN LA PARRILLA.