

Tank- und Motorschutzbügel HONDA NT 700 V Deauville

Artikel Nr.:
501.944 00 01 schwarz

Montage

Der Bausatz umfaßt die folgenden Teile:

Stück	Bestellnr.	Bezeichnung
1	701.501HB	Motorschutzbügel links
1	701.502HB	Motorschutzbügel rechts
1	701.503HB	Schutzbügel – Oberteil
1	151.018	Inbusschraube M 10 x 150
2	150.811	U-Scheiben ø10,5
1	150.801	selbstsichernde Mutter M 10
2	151.019	Kreuzschlitzschrauben M 5 x 50
2	270.112	U-Scheiben ø5,4
2	151.020	Stiftschraube M 6

Seitenkoffer
Topcases
Gepäckträger
Lock it System
Softbags
Aluminiumkoffer
Lederkoffer
Schutzbügel
Hauptständer
Chopper-Parts
Quad-Parts
Accessoires



**Nach der Montage alle Verschraubungen auf festen Sitz kontrollieren!
Bitte beachten Sie unsere beigelegten Serviceinformationen.**

Weiteres Zubehör:
Gepäckbrücke Art.-Nr. 650.944 01 01 in schwarz



Hepco & Becker GmbH
An der Steinmauer 6
D-66955 Pirmasens
Germany

Tel.: +49 6331 - 1453 - 100
Fax: +49 6331 - 1453 - 120
eMail: vertrieb@hepco-becker.de
www.hepco-becker.de

Tank- und Motorschutzbügel HONDA NT 700 V Deauville

Artikel Nr.:
501.944 00 01 schwarz

Seitenkoffer
Topcases
Gepäckträger
Lock it System
Softbags
Aluminiumkoffer
Lederkoffer
Schutzbügel
Hauptständer
Chopper-Parts
Quad-Parts
Accessoires



Montage

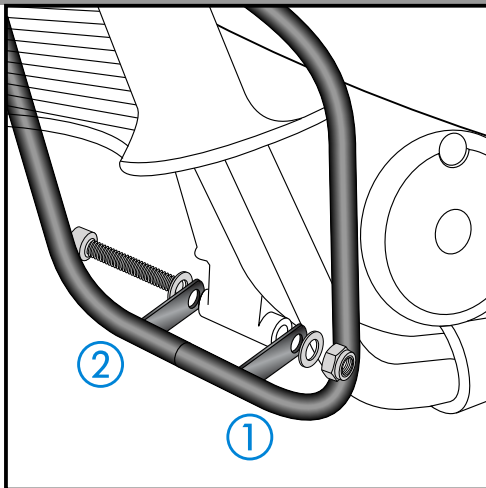

1

Befestigung unten:

Beide Motorschutzbügel links ① und rechts ② zusammenstecken. Die unteren Haltetaschen am Motorgehäuse verschrauben. Hierzu die Inbusschraube M 10 x 150 (von rechts durchstecken) nebst U-Scheiben ø10,5 und selbstsichernder Mutter M 10 verwenden.

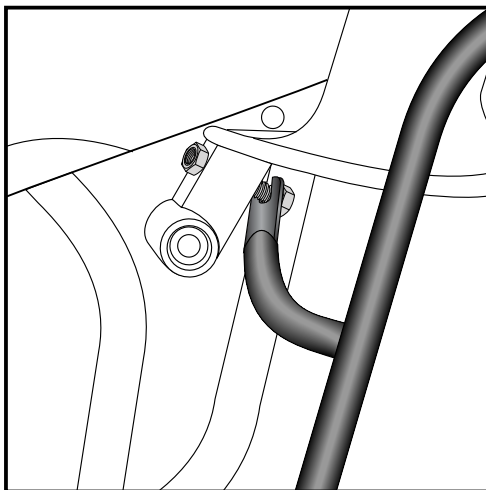

2

Befestigung mittig:

Beide durchgehenden Original-Schrauben M 8 mit Muttern soweit lösen, dass die geschlitzten Rohrlaschen eingeschoben werden können. Erst nach der Montage des Schutzbügel-Oberteils die Schrauben festziehen.

Rechts

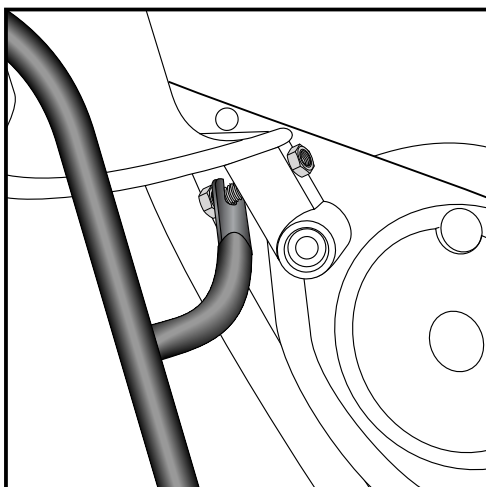

3

Links

Tank- und Motorschutzbügel HONDA NT 700 V Deauville

Artikel Nr.:
501.944 00 01 schwarz

Seitenkoffer
Topcases
Gepäckträger
Lock it System
Softbags
Aluminiumkoffer
Lederkoffer
Schutzbügel
Hauptständer
Chopper-Parts
Quad-Parts
Accessoires



Montage

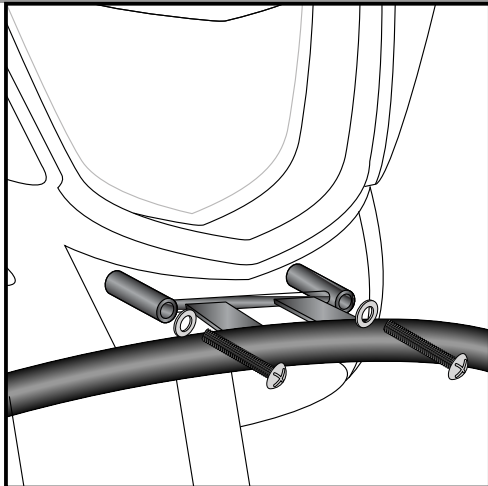

4 Befestigung des Schutzbügel-Oberteils - Vorne:
Unterhalb des Scheinwerfers. Beide Originalschrauben demontieren.
Befestigung mit den Kreuzschlitzschrauben M 5 x 50 nebst U-
Scheiben $\varnothing 5,4$.

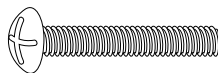

je 2x

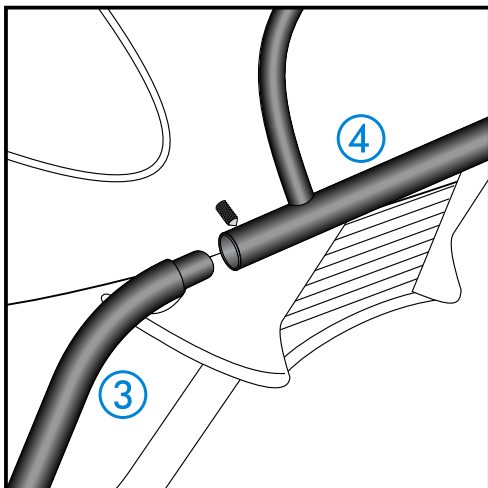

5 Befestigung des Schutzbügel-Oberteils **4** - Seitlich:
Auf die verjüngten Enden der Motorschutzbügel **3** aufstecken und
mit den Stiftschrauben M 6 sichern.



2 x



Den Tank- und Motorschutzbügel ausrichten und danach alle
Verschraubungen festziehen.

Tank + Engine guard
HONDA NT 700 V Deauville

Item-No.
501.944 00 01 black

Side cases
Top cases
luggage frames
Lock it system
Softbags
Aluminium luggage
Leather luggage
Protection bars
Center stands
Chopper parts
Quad parts
Accessories



Assembling instructions

The kit includes the following parts:

quant	item no.	description
1	701.501HB	crash bar left
1	701.502HB	crash bar right
1	701.503HB	tank guard
1	151.018	allen screw M 10 x 150
2	150.811	washer ø10,5
1	150.801	self-lock nut M 10
2	151.019	Phillips-head screw M 5 x 50
2	270.112	washer ø5,4
2	151.020	stud bolt M 6



Control all screw connections after the assembling for tightness!

Please notice our enclosed service information.

All screws, bots und nuts should be checked after driving the first 50 km to ensure that all are tightened to the proper torque.

Medium strength liquid thread-locker (i.e., „Locktite“) should be used to secure all screws, bolts, and nuts.

Also available:

Rear rack 650.944 01 01 black



Hepco & Becker GmbH
An der Steinmauer 6
D-66955 Pirmasens

Tel.: 06331 - 1453 - 100
Fax: 06331 - 1453 - 120
eMail: vertrieb@hepco-becker.de
www.hepco-becker.de

Tank + Engine guard
HONDA NT 700 V Deauville

Item-No.
501.944 00 01 black

- Side cases
- Top cases
- luggage frames
- Lock it system
- Softbags
- Aluminium luggage
- Leather luggage
- Protection bars
- Center stands
- Chopper parts
- Quad parts
- Accessories



Assembling instructions

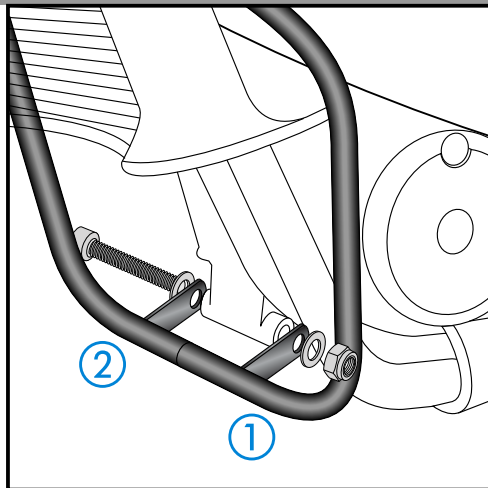

1

Fastening of the crash bar bottom front:

Connect crash bar left ① and right. ②

Fix the shackles at the engine with allen screw M 10 x 150 (from right to left side) washers ø10,5 and self-lock nut M 10.

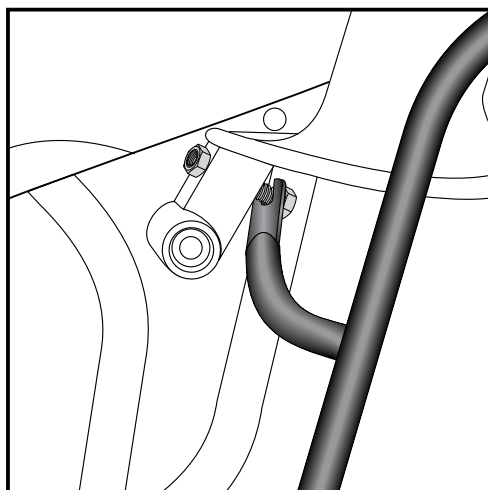

2

Fastening of the crash bar in the middle:

Unscrew original screws M 8 so far, that the slotted shackles can be moved behind.

The screws will be tightened after assembling the tank guard !

right side

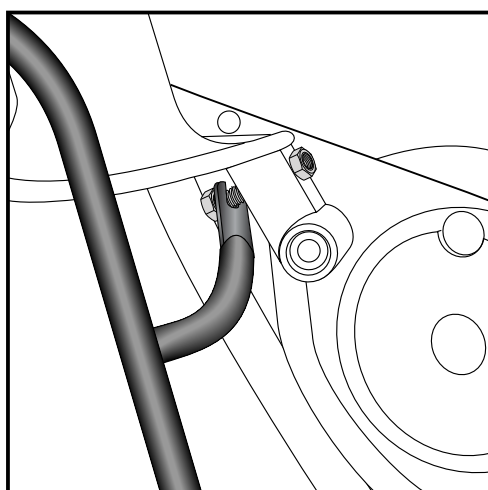

3

left side

Tank + Engine guard
HONDA NT 700 V Deauville

Item-No.
501.944 00 01 black

- Side cases
- Top cases
- luggage frames
- Lock it system
- Softbags
- Aluminium luggage
- Leather luggage
- Protection bars
- Center stands
- Chopper parts
- Quad parts
- Accessories



Assembling instructions

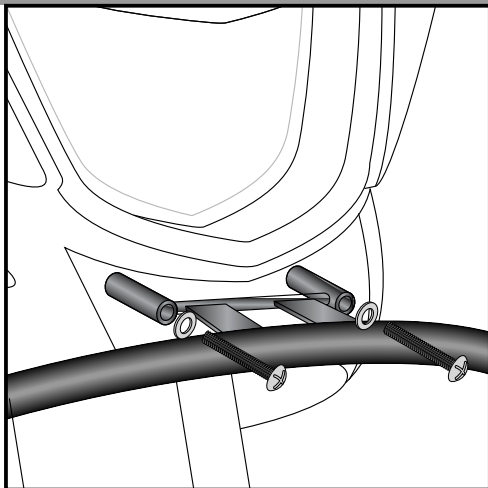

4 Fastening of the tank guard front:
Under the headlight. Unmount original screws.
Fix the tank guard with Phillips-head screw M 5 x 50 and washer $\varnothing 5,4$.

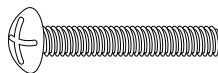

each 2x

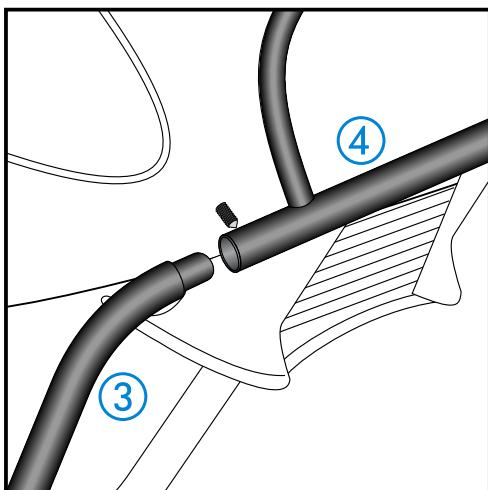

5 Fastening of the tank guard side:
Fit in the tank guard **4** at the tapered end of the crash bar **3** and secure it with stud bolt M 6.



2 x



Adjust tank guard and crash bar and tighten all screws.