

Tankschutzbügel



KRAUSER[®]
MOTORRADGEPÄCKSYSTEME ■ BIKE BAGS

SUZUKI V-Strom 1000 ABS
ab Baujahr 2014

502.3530 00 01 schwarz

SUZUKI V-Strom 1000 ABS
ab Baujahr 2014

3003.054.201 schwarz

Montage

Der Bausatz umfaßt die folgenden Teile:

Stück	Bestellnr.	Bezeichnung			
1	700008549	Tankschutzbügel links	8	150.995	U-Scheiben ø8,4
1	700008550	Tankschutzbügel rechts	4	150.810	U-Scheiben ø6,4
1	700008551	Halteadapter vorne	2	150.999	U-Scheiben ø16,5 x ø8,5 x 3mm
2	150.782	Inbusschraube M8 x 20	4	150.800	selbstsichernde Mutter M8
2	150.844	Sechskantschrauben M8 x 45	4	270.105	Kunststoffkappen M6
4	150.828	Sechskantschrauben M6 x 16			

HINWEIS

Dieser Tankschutzbügel kann nur in Verbindung mit dem Motorschutzbügel 501.3530 montiert werden.

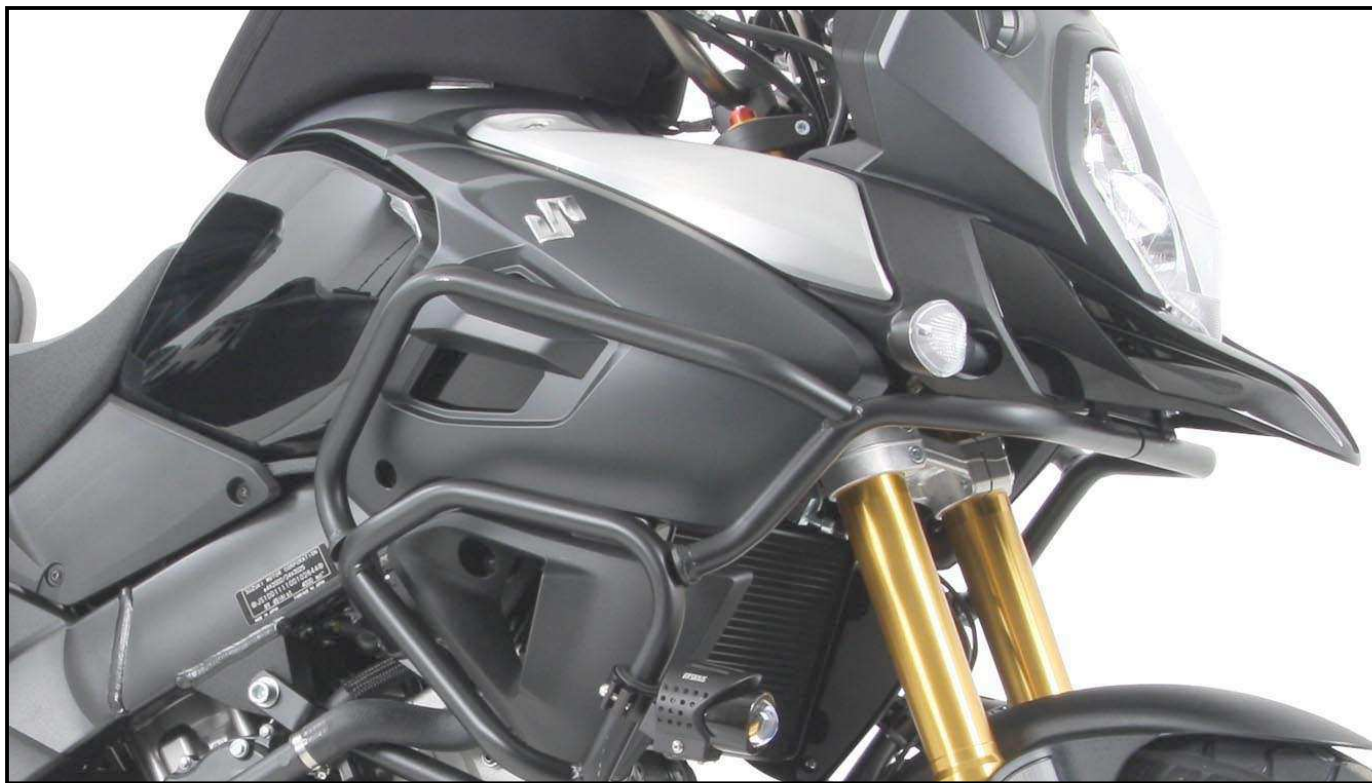

Als weiteres Zubehör lieferbar:
Kofferträger (Lock it System, abnehmbar)
Gepäckbrücke (Alurack)
Hauptständer
C-Bow Halter für Softtaschen
Motorschutzplatte
und weitere Teile.

Anzugsmomente des Motorradherstellers beachten!
Nach der Montage alle Verschraubungen auf festen Sitz kontrollieren!
Bitte beachten Sie unsere beigefügten Serviceinformationen.



Hepco & Becker GmbH
An der Steinmauer 6
D-66955 Pirmasens
Tel.: 0049 6331 - 1453 - 100
www.hepco-becker.de



Krauser GmbH
An der Steinmauer 6
D-66955 Pirmasens
Tel.: 0049 6331 - 1453 - 250
www.krauser.de

Tankschutzbügel



SUZUKI V-Strom 1000 ABS
ab Baujahr 2014

502.3530 00 01 schwarz

SUZUKI V-Strom 1000 ABS
ab Baujahr 2014

3003.054.201 schwarz

Montage

Montage des Halteadapters vorne oben: **1**

Die zwei Original-Schrauben des Cockpithalters durch die Sechskantschrauben M8x45 mit U-Scheibe $\varnothing 8,4$ ersetzen.
Zwischen Rahmen und Adapter je eine U-Scheibe $\varnothing 16,5 \times \varnothing 8,5 \times 3\text{mm}$ fügen.

An dem überstehenden Gewinde den Adapter mit den selbstsichernden Muttern M8 sowie U-Scheiben $\varnothing 8,4$ verschrauben.

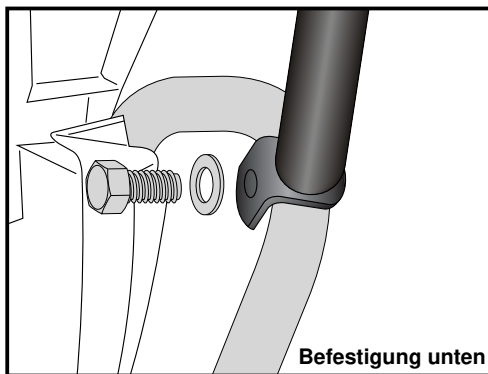
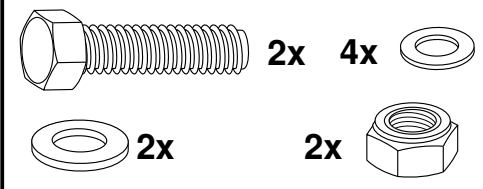

2

Montage der Tankschutzbügel links und rechts:

Diese werden an den freien Gewinden an den Innenseiten der Motorschutzbügel mit den Sechskantschrauben M6x16 sowie U-Scheiben $\varnothing 6,4$ verschraubt.

Zuerst die rechte Seite danach die linke Seite.

Schrauben noch nicht ganz festziehen.

Später mit den Kunststoffkappen abdecken.

TIPP:

Die Tankschutzbügel am besten an den demontierten Motorschutzbügeln befestigen und dann komplett montieren.

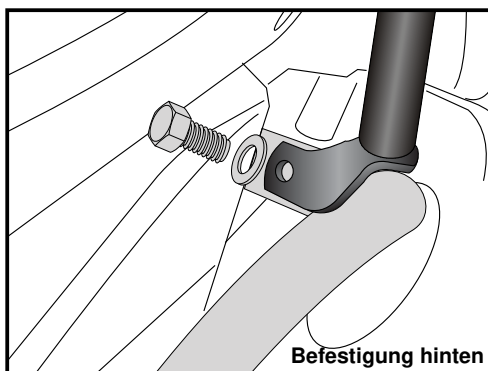

3

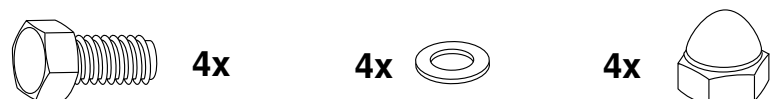

Tankschutzbügel



KRAUSER[®]
MOTORRADGEPÄCKSYSTEME ■ BIKE BAGS

SUZUKI V-Strom 1000 ABS
ab Baujahr 2014

502.3530 00 01 schwarz

SUZUKI V-Strom 1000 ABS
ab Baujahr 2014

3003.054.201 schwarz

Montage

Montage des Tankschutzbügel vorne:
unterhalb des Kotflügels zusammen-
stecken und mit den Inbusschrauben
M8x20 sowie U-Scheiben $\varnothing 8,4$ sowie
selbstsichernden Muttern M8 an dem
zuvor montierten Halteadapter
verschrauben. (In Fahrtrichtung davor)

Alle Teile ausrichten und festziehen.

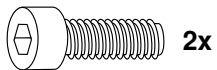

4

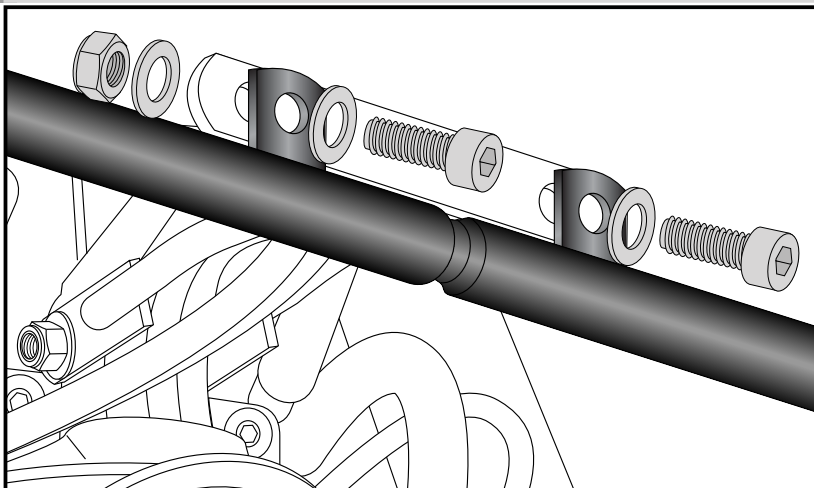

Empfehlenswertes Zubehör:
Ion Blue Flooter (Artikel-Nr. 730105).

Tank guard



KRAUSER[®]
MOTORRADGEPÄCKSYSTEME ■ BIKE BAGS

SUZUKI V-Strom 1000 ABS
from date of manufacture 2014

502.3530 00 01 black

SUZUKI V-Strom 1000 ABS
from date of manufacture 2014

3003.054.201 black

Assembling instructions

The kit includes the following parts:

Quant	item no.	description			
1	700008549	tank guard left	8	150.995	washer ø8,4
1	700008550	tank guard right	4	150.810	washer ø6,4
1	700008551	adapter front	2	150.999	washer ø16,5 x ø8,5 x 3mm
2	150.782	allen screw M8 x 20	4	150.800	self lock nut M8
2	150.844	hexagon bolt M8 x 45	4	270.105	plastic cap M6
4	150.828	hexagon bolt M6 x 16			

NOTICE

This Tank guard can only be fitted in connection with the engine guard 501.3530.

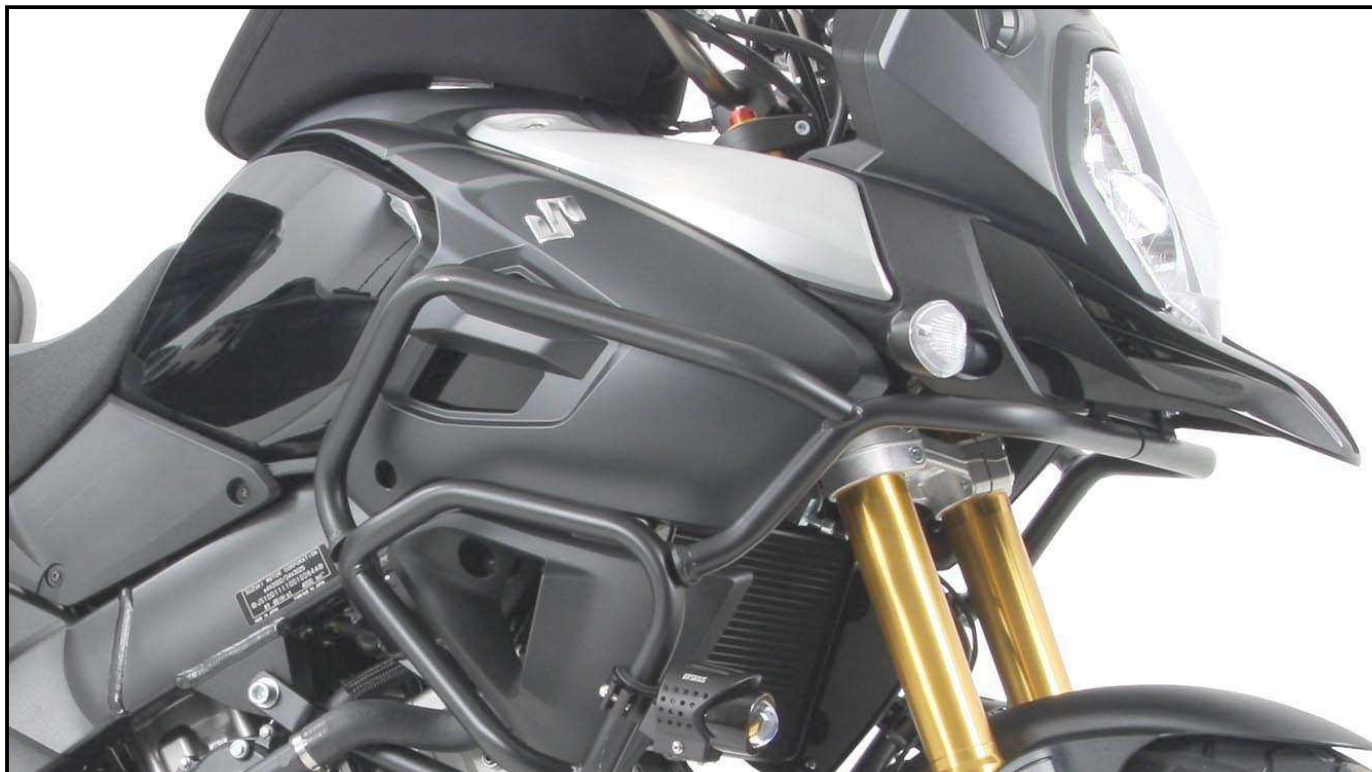

Also available:

Side carrier (Lock it System, removable)

Rear rack (Alurack)

Center stand

C-Bow Holder for softbags

Skid plate

and more....

**Control all screw connections after the assembling for tightness!
Please notice our enclosed service information.**



Hepco & Becker GmbH
An der Steinmauer 6
D-66955 Pirmasens
Tel.: 0049 6331 - 1453 - 100
www.hepco-becker.de



Krauser GmbH
An der Steinmauer 6
D-66955 Pirmasens
Tel.: 0049 6331 - 1453 - 250
www.krauser.de

Tank guard



SUZUKI V-Strom 1000 ABS
from date of manufacture 2014

502.3530 00 01 black

SUZUKI V-Strom 1000 ABS
from date of manufacture 2014

3003.054.201 black

Assembling instructions

1 Fastening of the adapters front top:
Change the two original screws of the cockpit holder with hexagon screws M8x45 with washers $\varnothing 8,4$.
Add washer $\varnothing 16,5 \times \varnothing 8,5 \times 3\text{mm}$ between adapter and frame.

Fix the adapter with washers $\varnothing 8,4$ and self lock nuts at the threads of the hexagon screws.

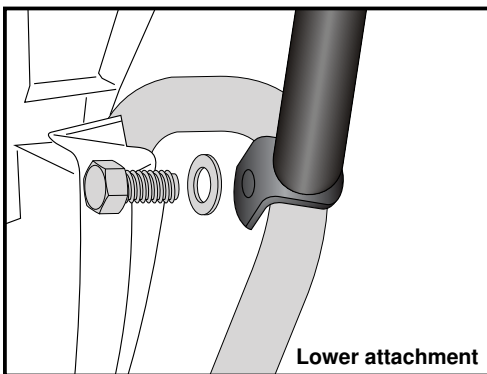
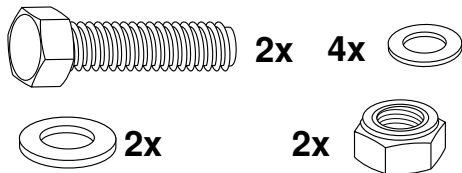

2 Fastening of the tank guard left + right:
at the free threads inside the engine guard tubes with hexagon bolts M6x16 with washers $\varnothing 6,4$.
Start with the right side.
Do not fully tighten yet.
Later, cover with plastic caps.

TIP:
It is easier, to fix the Tank guards first to the disassembled engine guards, and then install completely.

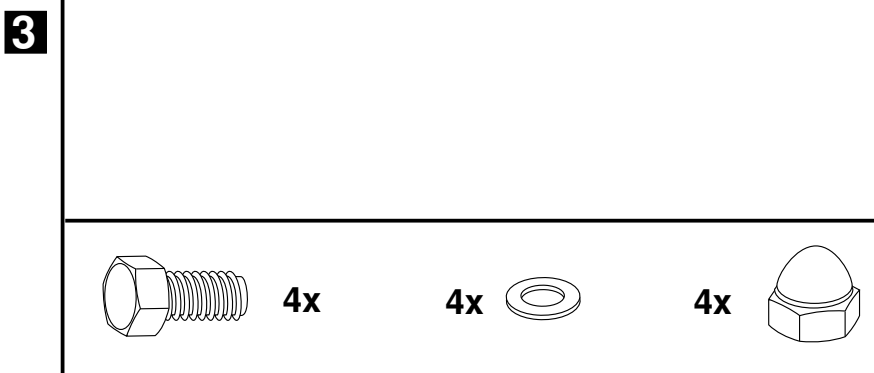
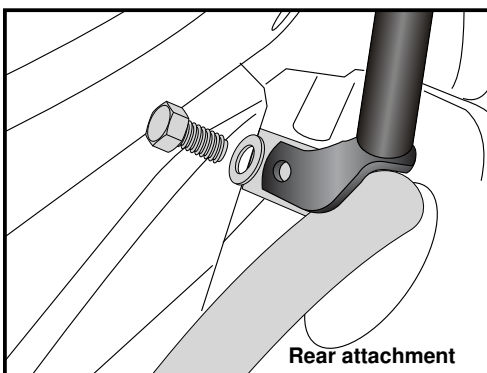

Tank guard



KRAUSER[®]
MOTORRADGEPÄCKSYSTEME ■ BIKE BAGS

SUZUKI V-Strom 1000 ABS
from date of manufacture 2014

502.3530 00 01 black

SUZUKI V-Strom 1000 ABS
from date of manufacture 2014

3003.054.201 black

Assembling instructions

Fastening of the Tank guard front:
stuck together beneath the fender and fix it to front of the adapter with allen screws M8x20, washers ø8,4 and self lock nuts M8.

Now screw on all nuts and bolts to the torque specific.

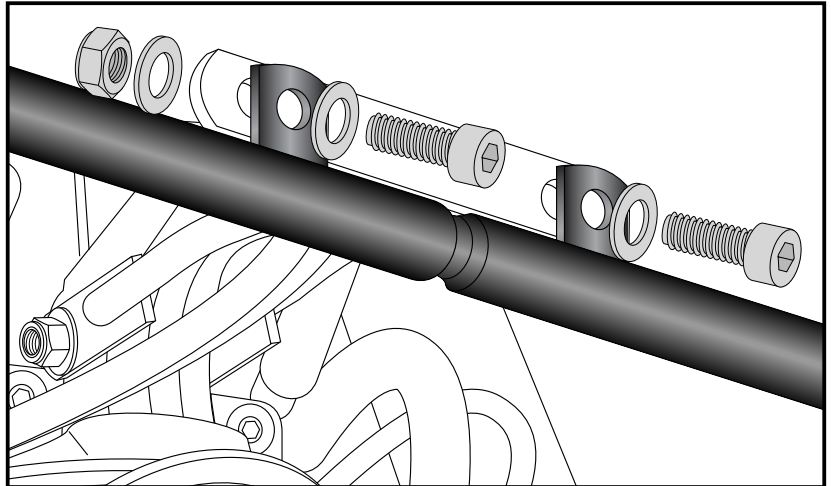
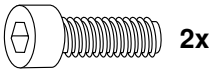

Recommended Accessories:
Ion Blue Floater (Item-no. 730105).