

PORTAVALIGIA SPECIFICO - SPECIFIC CASE HOLDER
 PORTE-VALISE SPÉCIFIQUE - SPEZIFISCHER KOFFER-TRÄGER
 PORTA-EQUIPAJE ESPECÍFICO

APRILIA PEGASO 650 2005 STRADA

ISTRUZIONI DI MONTAGGIO - MOUNTING INSTRUCTIONS
 INSTRUCTIONS DE MONTAGE - BAUANLEITUNG - INSTRUCCIONES DE MONTAJE

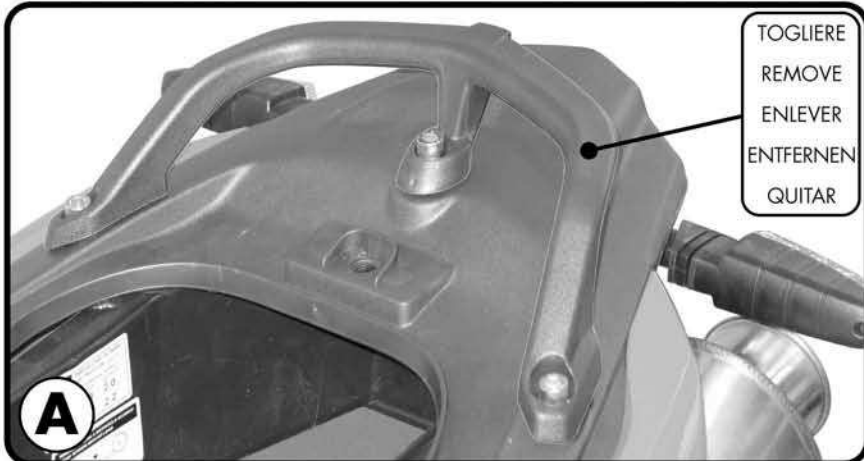

ATTENZIONE
PESO MASSIMO
SOPPORTABILE DAL
PORTAPACCO
6Kg.

WARNING
MAX. LOADING OF THE
CARRIER 6Kg. (13lbs)

ATTENTION
CHARGE MAXIMALE 6Kg.

ACHTUNG
MAXIMALE BELASTUNG
DES TRÄGERS 6Kg.

¡ATENCIÓN!
CARGA MÁXIMA
AUTORIZADA 6Kg.

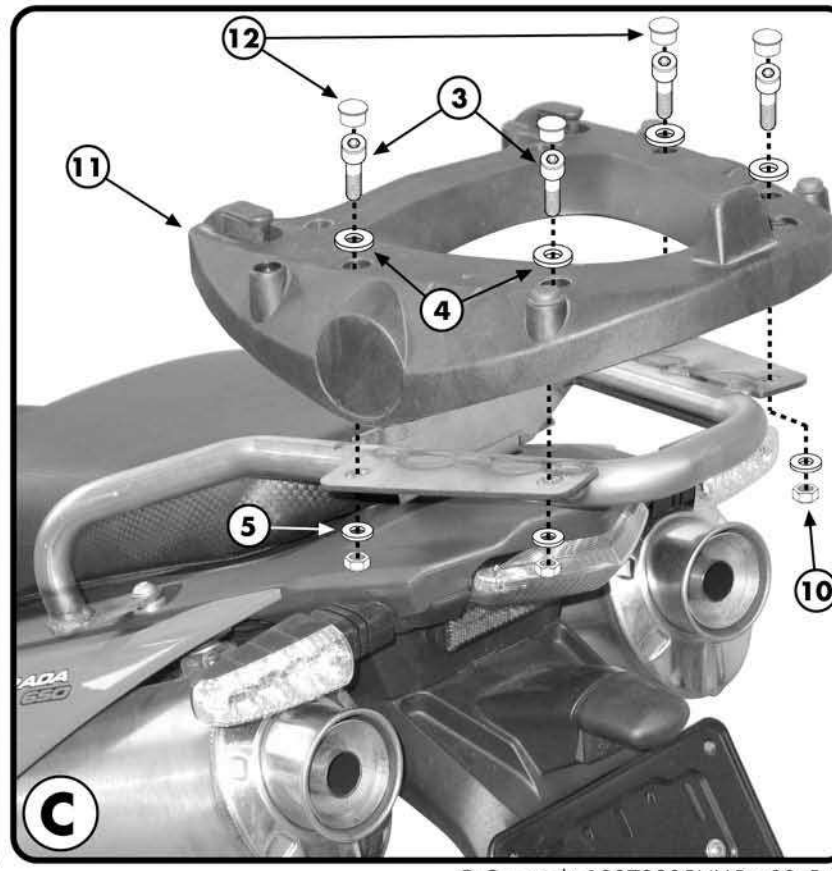
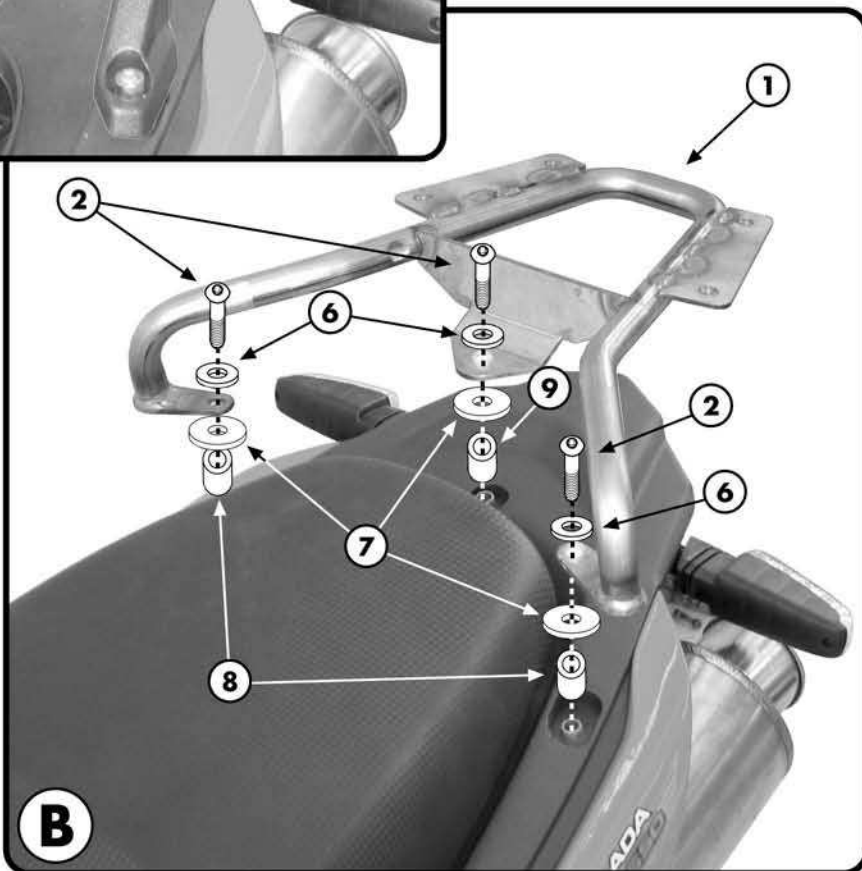

PORTAVALIGIA SPECIFICO - SPECIFIC CASE HOLDER
 PORTE-VALISE SPECIFIQUE - SPEZIFISCHER KOFFER-TRÄGER
 PORTA-EQUIPAJE ESPECIFICO

APRILIA PEGASO 650 2005 STRADA

ISTRUZIONI DI MONTAGGIO - MOUNTING INSTRUCTIONS
 INSTRUCTIONS DE MONTAGE - BAUANLEITUNG - INSTRUCCIONES DE MONTAJE

I ISTRUZIONI DI MONTAGGIO

1. SMONTARE IL MANIGLIONE ORIGINALE INDICATO IL FOTOGRAFIA A;
2. MONTARE IL SUPPORTO N°1 COME ILLUSTRATO IN FOTOGRAFIA B;
3. FISSARE LA PIASTRA PORTAVALIGIA COME MOSTRATO IN FOTOGRAFIA C;
4. ULTIMARE IL MONTAGGIO VERIFICANDO CHE TUTTE LE VITI SIANO SERRATE BENE E CHE IL TAPPO ANTIFURTO ED I GOMMINI SIANO MONTATI CORRETTAMENTE SULLA PIASTRA.

GB MOUNTING INSTRUCTIONS

1. REMOVE THE ORIGINAL GRAB RAILS AS SHOWN IN PICTURE A;
2. MOUNT THE SUPPORT N° 1 AS SHOWN IN PICTURE B;
3. FIX THE REAR PLATE AS SHOWN IN PICTURE C;
4. LASTLY CHECK THAT ALL SCREWS HAVE BEEN TIGHTENED AND THAT THE RUBBERS AND THE ANTI-THEFT CAP HAD BEEN CORRECTLY POSITIONED ON THE PLATE.

F INSTRUCTIONS DE MONTAGE

1. DEMONTER LA POIGNEE D'ORIGINE INDIQUEE EN PHOTO A;
2. MONTER LE SUPPORT N°1 COMME ILLUSTRE EN PHOTO B;
3. FIXER LA PLATINE COMME MONTRE EN PHOTO C;
4. TERMINER LE MONTAGE EN CONTROLANT LE BON SERRAGE DE TOUTES LES VIS ET EN VERIFIANT QUE LE BOUCHON ANTIVOL ET LES GOMMES SOIENT MONTES CORECTEMENT SUR LA PLATINE.

D BAUANLEITUNG

1. ENTFERNEN SIE DEN ORIGINAL HANDGRIFF WIE IM BILD A BESCHRIEBEN;
2. MONTIEREN SIE DIE HALTERUNG NR. 1 WIE IM BILD B BESCHRIEBEN;
3. BEFESTIGEN SIE DIE GEPÄCKPLATTE WIE IM BILD C BESCHRIEBEN;
4. ZULETZT ÜBERPRÜFEN SIE, DASS ALLE SCHRAUBEN FESTGEZOGEN WURDEN UND DASS DIE GUMMISTÜPSEL SOWIE DIE DIEBSTAHL SICHERUNG AUF DER PLATTE KORREKT POSITIONIERT WURDEN.

ES

INSTRUCCIONES DE MONTAJE

1. DESMONTAR EL ASA TRASERA ORIGINAL COMO INDICA LA FOTO A
2. MONTAR EL SOPORTE N° 1 COMO INDICA LA FOTO B;
3. ANCLAR LA PARRILLA COMO INDICA LA FOTO C;
4. TERMINAR EL MONTAJE CONTROLANDO QUE TODOS LOS TORNILLOS ESTÉN BIEN APRETADOS Y QUE EL TAPÓN ANTIRROBO Y LAS GOMAS ANTI-VIBRACIONES ESTEN BIEN MONTADAS SOBRE LA PARRILLA.