

# CRM102

BORSA LATERALE SINGOLA, 16 LT - SINGLE SIDE BAG, 16 LTR - EINZELNE SEITENTASCHE, 16 L  
SACOCHE CAVALIÈRE, 16 LITRES - ALFORJA LATERAL INDIVIDUAL, 16 LTS - BOLSA LATERAL, 16 LTS

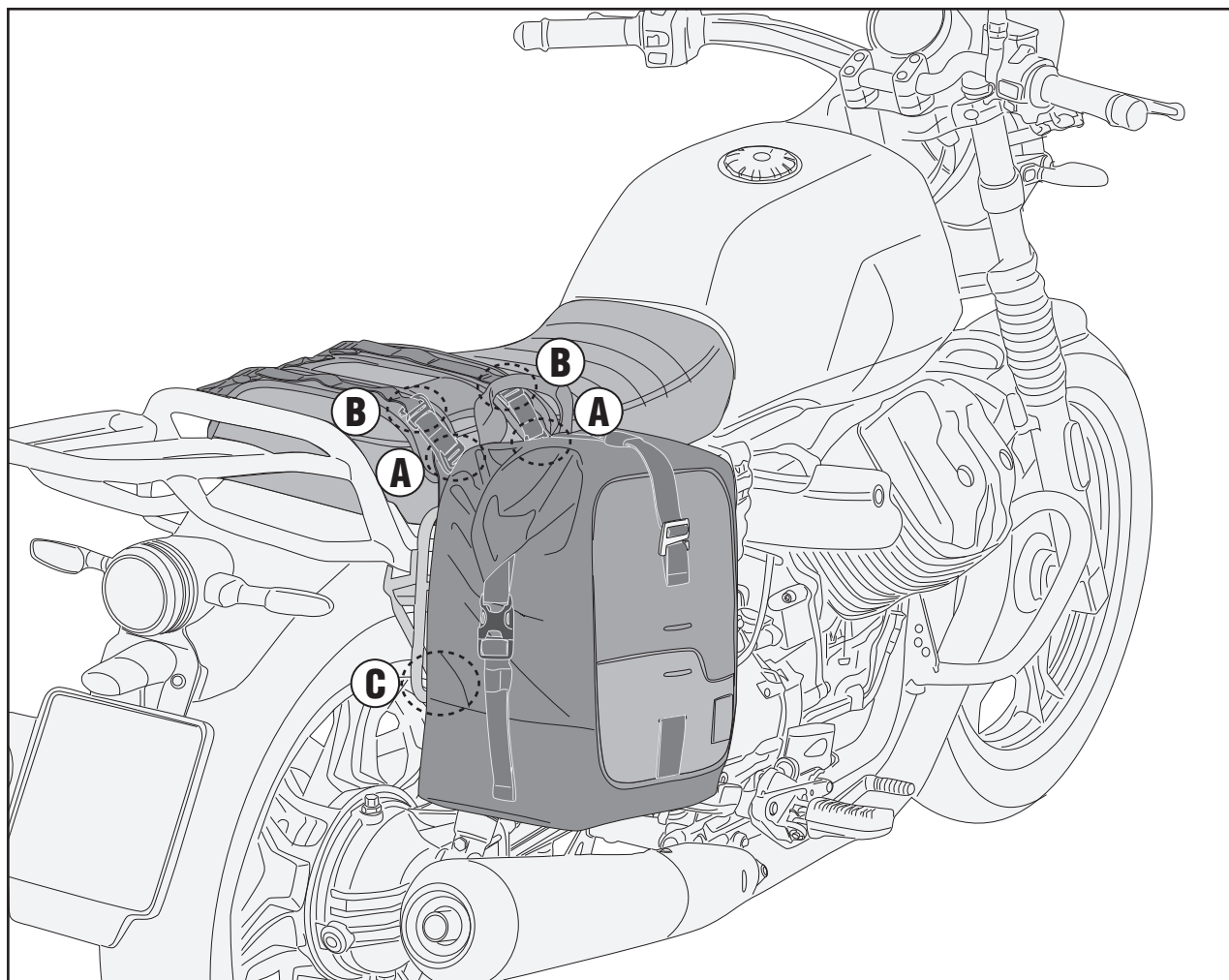

**ATTENZIONE:** Verificare il corretto aggancio della borsa prima di mettersi in marcia.  
**WARNING:** Fasten the bag securely before setting off.  
**ATTENTION:** Vérifier la bonne accroche de sacoches avant la mise en route.  
**ACHTUNG:** Prüfen Sie bitte die Befestigung die Tasche bevor Sie fahren  
**ATENCIÓN:** Comprobar si esta correcto el anclaje de la bolsa antes de ponerse en marcha.  
**ATENÇÃO:** Verificar se correta fixação da Bolsa antes de começar.

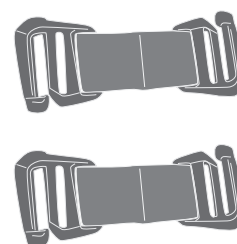

# CRM102

BORSA LATERALE SINGOLA, 16 LT - SINGLE SIDE BAG, 16 LTR - EINZELNE SEITENTASCHE, 16 L  
SACOCHE CAVALIÈRE, 16 LITRES - ALFORJA LATERAL INDIVIDUAL, 16 LTS - BOLSA LATERAL, 16 LTS

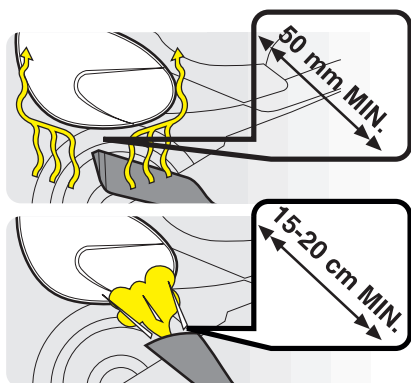

**ATTENZIONE:** Tenere la borsa a una

ragionevole distanza dalla marmitta. Il calore e i fumi di scarico potrebbero danneggiarla.

**WARNING:** Keep the bag a reasonable distance from the silencer. The heat and the exhaust could damage it.

**ATTENTION:** Tenez le sacoche à une distance raisonnable du système d'échappement. La chaleur et les gaz d'échappement pourraient le endommager.

**ACHTUNG:** Die Taschen in ausreichendem Abstand vom Auspuff andringen, um deren Beschädigung durch Hitze und Abgase zu vermeiden.

**ATENCIÓN:** Mantener la bolsa en una distancia razonable del tubo de escape. El calor y los humos de escape podrían dañarlos.

**ATENÇÃO:** Mantenha a bolsa a uma distância razoável do tubo de escape, pois o calor e a fumaça dos gases de escape podem danificá-los.

**ATTENZIONE:** Per il fissaggio è necessario l'utilizzo della fascia da sella CRM105 (acquistabile separatamente).

**WARNING:** Use the CRM105 saddle strap to fasten the bag (sold separately).

**ATTENTION:** Pour la fixation, il est nécessaire d'utiliser la sangle de selle CRM105 (disponible séparément).

**ACHTUNG:** Für die Befestigung wird das Sattelband CRM105 benötigt (separat erhältlich).

**ATENCIÓN:** Para fijarla, es necesario utilizar la banda de sillín CRM105 (se vende por separado).

**ATENÇÃO:** Para a fixação, é necessário utilizar a faixa para banco CRM105 (vendida separadamente).

CHOOSE THE HOLE ACCORDING TO THE RIGHT BAG HEIGHT

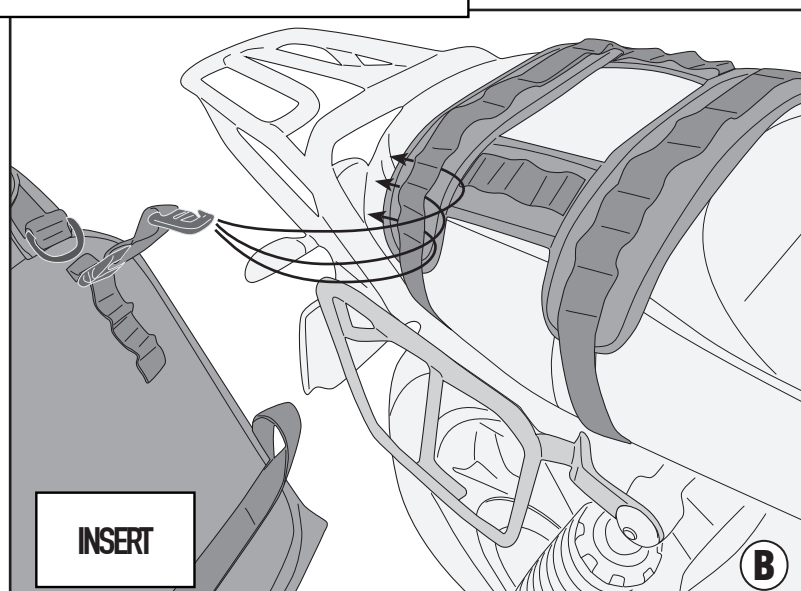
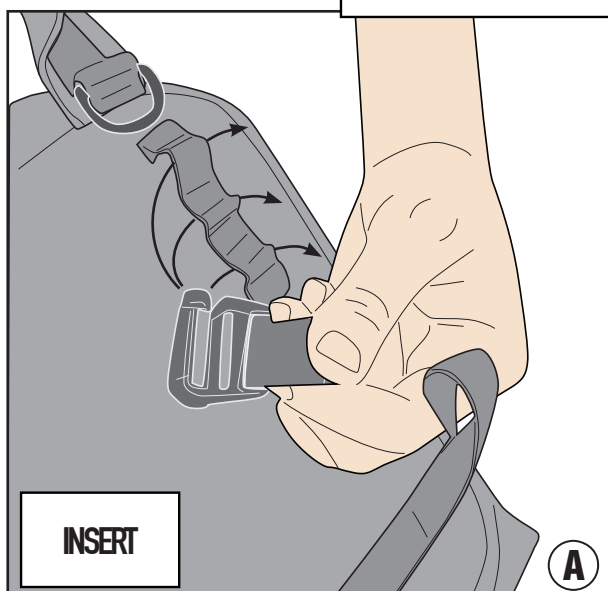

# CRM102

BORSA LATERALE SINGOLA, 16 LT - SINGLE SIDE BAG, 16 LTR - EINZELNE SEITENTASCHE, 16 L  
SACOCHE CAVALIÈRE, 16 LITRES - ALFORJA LATERAL INDIVIDUAL, 16 LTS - BOLSA LATERAL, 16 LTS

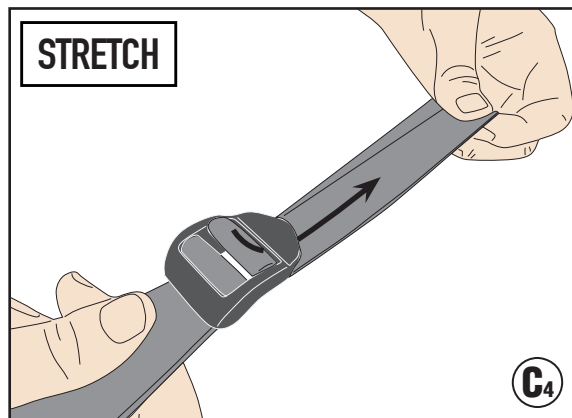
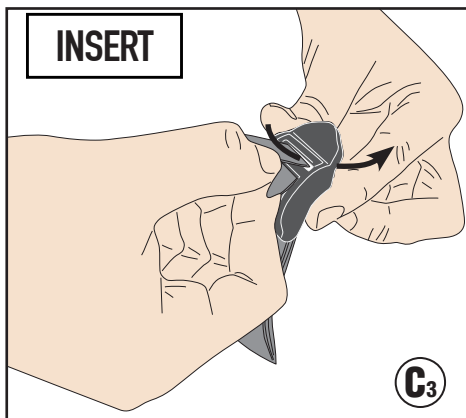
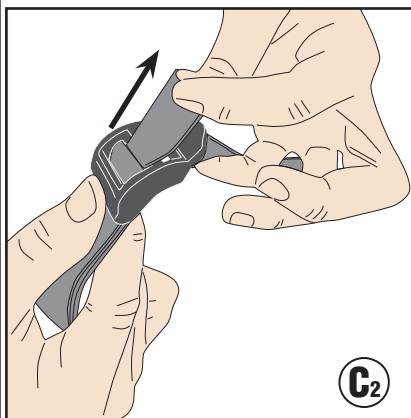
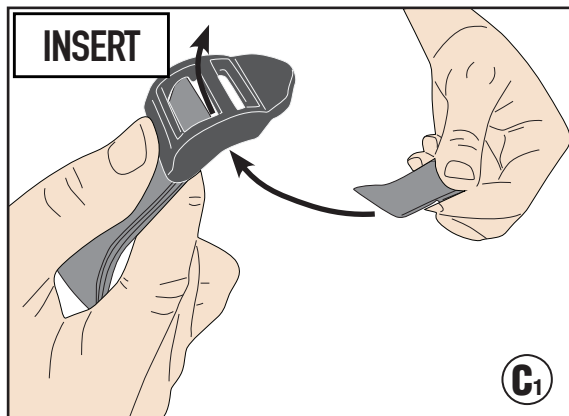
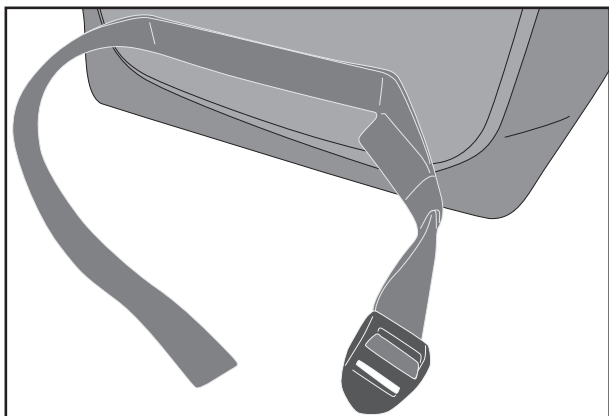
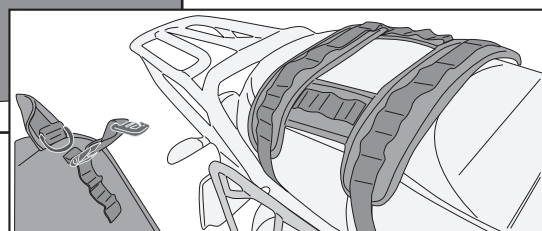
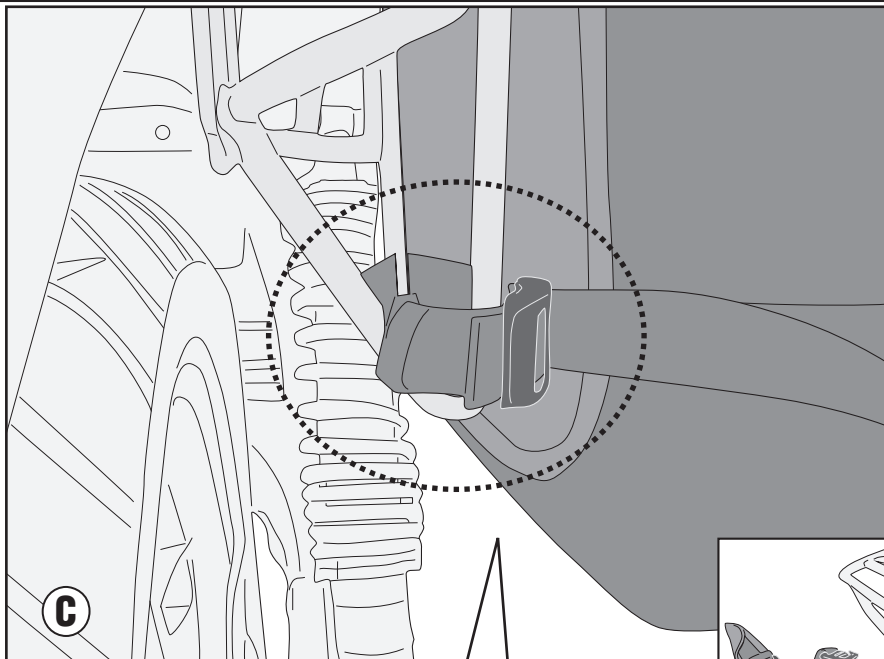

# CRM102

BORSA LATERALE SINGOLA, 16 LT - SINGLE SIDE BAG, 16 LTR - EINZELNE SEITENTASCHE, 16 L  
SACOCHE CAVALIÈRE, 16 LITRES - ALFORJA LATERAL INDIVIDUAL, 16 LTS - BOLSA LATERAL, 16 LTS

**ATTENZIONE:** Per Garantire L'impermeabilità Della Borsa Seguire Le Istruzioni Per La Chiusura.

**WARNING:** To Guarantee The Bag's Impermeability, Follow The Closing Instructions.

**ATTENTION:** Permet De Garantir L'impermeabilité Du Sac, Suivre Les Instructions De Fermeture.

**ACHTUNG:** Um Die Undurchlässigkeit Der Tasche Zu Garantieren, Folgen Sie Bitte Den Anweisungen Zum Verschließen Der Tasche.

**ATENCIÓN:** Para Garantizar La Impermeabilidad De La Bolsa, Seguir Las Instrucciones De Cierre.

**ATENÇÃO:** Para Garantir A Impermeabilidade Da Bolsa Seguir As Instruções Para A Fechadura.

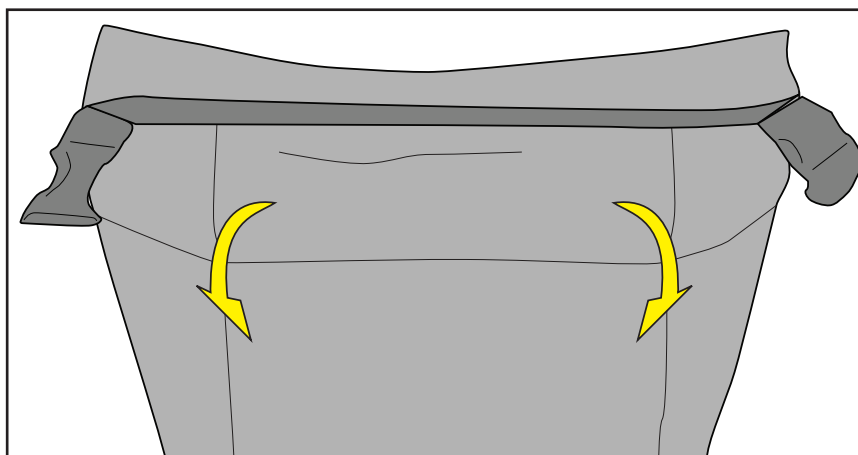

- ARROTOLARE PER 3 VOLTE SU SE STESSA L'APERTURA DELLA BORSA PER GARANTIRE L'IMPERMEABILITÀ
- TO ENSURE WATER RESISTANCE, IT IS ESSENTIAL TO ROLL DOWN THE OPENING OF THE BAG 3 TIMES
- ENROULER L'OUVERTURE DU SAC 3 FOIS SUR ELLE-MÊME AFIN D'ASSURER LA RÉSTANCE À L'EAU
- UM ZU GARANTIEREN, DASS DIE TASCHE WASSERRESISTENT IST, IST ES NOTWENDIG DEN VERSCHLUSS 3X EINZUROLLEN.
- ENROLLAR 3 VECES SOBRE SÍ MISMA LA APERTURA DE LA BOLSA PARA GARANTIZAR LA IMPERMEABILIDAD.
- ENROLAR PARA 3 VEZES A ABERTURA DA BOLSA PARA GARANTIR A SUA IMPERMEABILIDADE

## REMOVABLE INNER BAG

