

ES2145 - ES2145K

ESTENSIONE CAVALLETTO LATERALE - SIDE STAND EXTENSION - FUSSVERBREITERUNGEN FÜR SEITENSTÄNDER
 ZIJSTANDAARD EXTENSIE - EXTENSIÓN DEL CABALLETE LATERAL - EXTENSÃO DO CAVALETE LATERAL

YAMAHA Ténéré 700 (2019)

N°	Descrizione/Description	Caratteristiche/Features	Codice/Code	Quantità/Quantity
1	Supporto inferiore - Lower support - Support inférieur - Soporte inferior - Untere Halterung - Suporte inferior	Alluminio Sp.6mm	GL4310G	1
2	Supporto Centrale - Central support - Support centrale - Soporte Central - Halterung Zentrale - Suporte Central	Inox Sp.2mm	GL4311SP	1
3	Supporto superiore - Support higher - Support supérieur - Halterung höher - Soporte superior - Apoio superior	Inox Sp.2mm	GL4312SP	1
4	Vite - Screw Vis - Schraube Tornillo - Parafuso	-	M5x10 INOX	5
5	Mousse Protettiva - Protective Rubber Pads Mousse De Protection - Schutzgummi Espuma Adhesiva Protectora	20mm x 3mm x 50mm	MOUSSE3	1

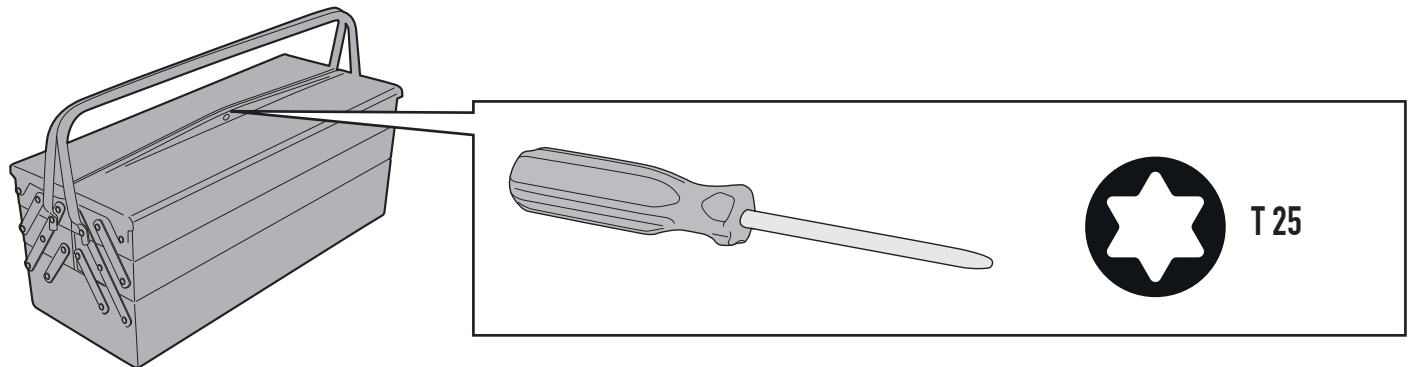
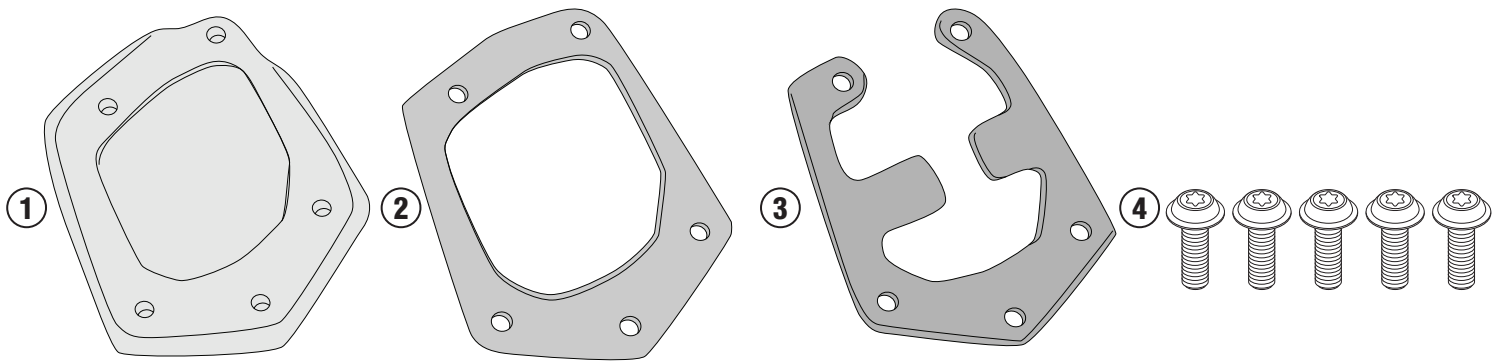

ES2145 - ES2145K

ESTENSIONE CAVALLETTO LATERALE - SIDE STAND EXTENSION - FUSSVERBREITERUNGEN FÜR SEITENSTÄNDER
ZIJSTANDAARD EXTENSIE - EXTENSIÓN DEL CABALLETE LATERAL - EXTENSÃO DO CAVALETE LATERAL

YAMAHA Ténéré 700 (2019)

ATTENZIONE: IL MONTAGGIO DELL' ESTENSIONE DEL CAVALLETTO, POTREBBE LIMITARE IL GRADO DI LIBERTÀ DI INCLINAZIONE DELLA MOTO.
APPLICARE ALCUNE GOCCE DI FRENA FILETTI SULLE VITI DI FISSAGGIO.

ATTENTION: MOUNTING OF STAND EXTENSION, COULD LIMIT LEAN ANGLE.
APPLY SOME THREADLOCK ON THE SCREWS

ATTENTION: MONTAGE DE L'EXTENSION DU PEUPEMENT, POURRAIT LIMITER L'ANGLE D'INCLINAISON.
APPLIQUER UN PEU DE FREIN-FILET SUR LES VIS

ACHTUNG: DER ANBAU DER FUSSVERBREITERUNGEN FÜR SEITENSTÄNDER KANN EINFLUSS AUF DIE SCHRÄGLAGENFREIHEIT DES FAHRZEUGS HABEN.
BRINGEN SIE ETWAS GEWINDEKLE AUF DEN SCHRAUBEN

ATENCIÓN: MONTAJE DE EXTENSIÓN SOPORTE, PODRÍA LIMITAR ÁNGULO DE INCLINACIÓN.
APLIQUE UN POCO DE FIJADOR DE ROSCAS EN LOS TORNILLOS

ATENÇÃO: MONTAGEM DE SUPORTE DE EXTENSÃO, PODERIA LIMITAR O ÂNGULO DE INCLINAÇÃO.
APLIQUE UM POUCO DE MASSA DE BLOQUEIO DE ROSCAS NOS PARAFUSOS

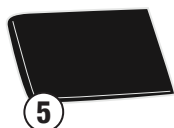
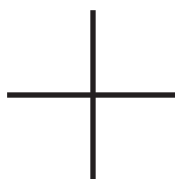
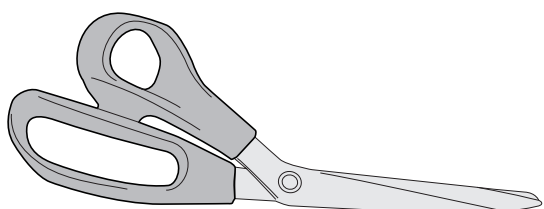
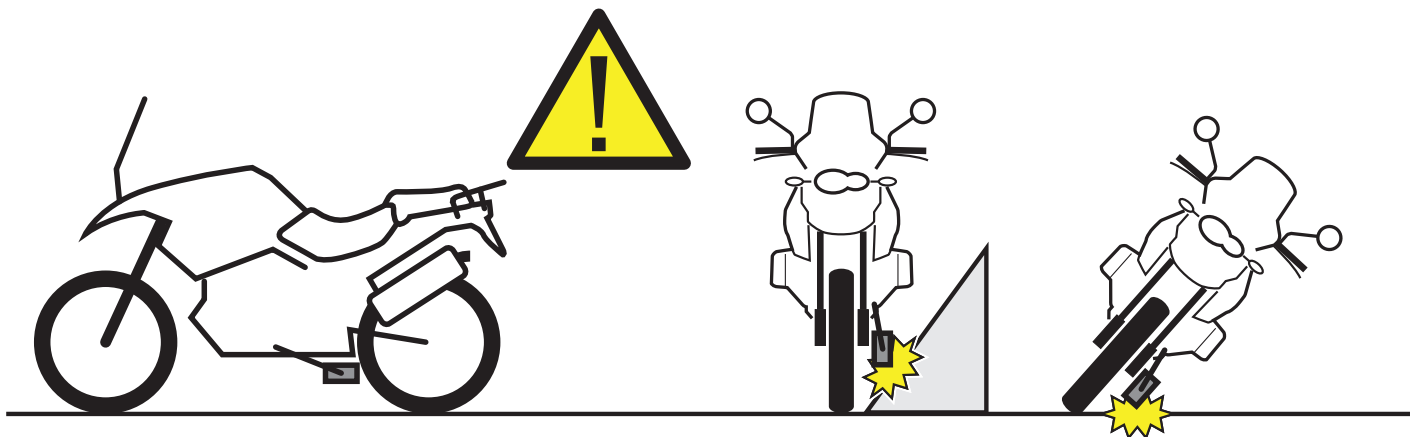

ES2145 - ES2145K

ESTENSIONE CAVALLETTO LATERALE - SIDE STAND EXTENSION - FUSSVERBREITERUNGEN FÜR SEITENSTÄNDER
ZIJSTANDAARD EXTENSIE - EXTENSIÓN DEL CABALLETE LATERAL - EXTENSÃO DO CAVALETE LATERAL

YAMAHA Ténéré 700 (2019)

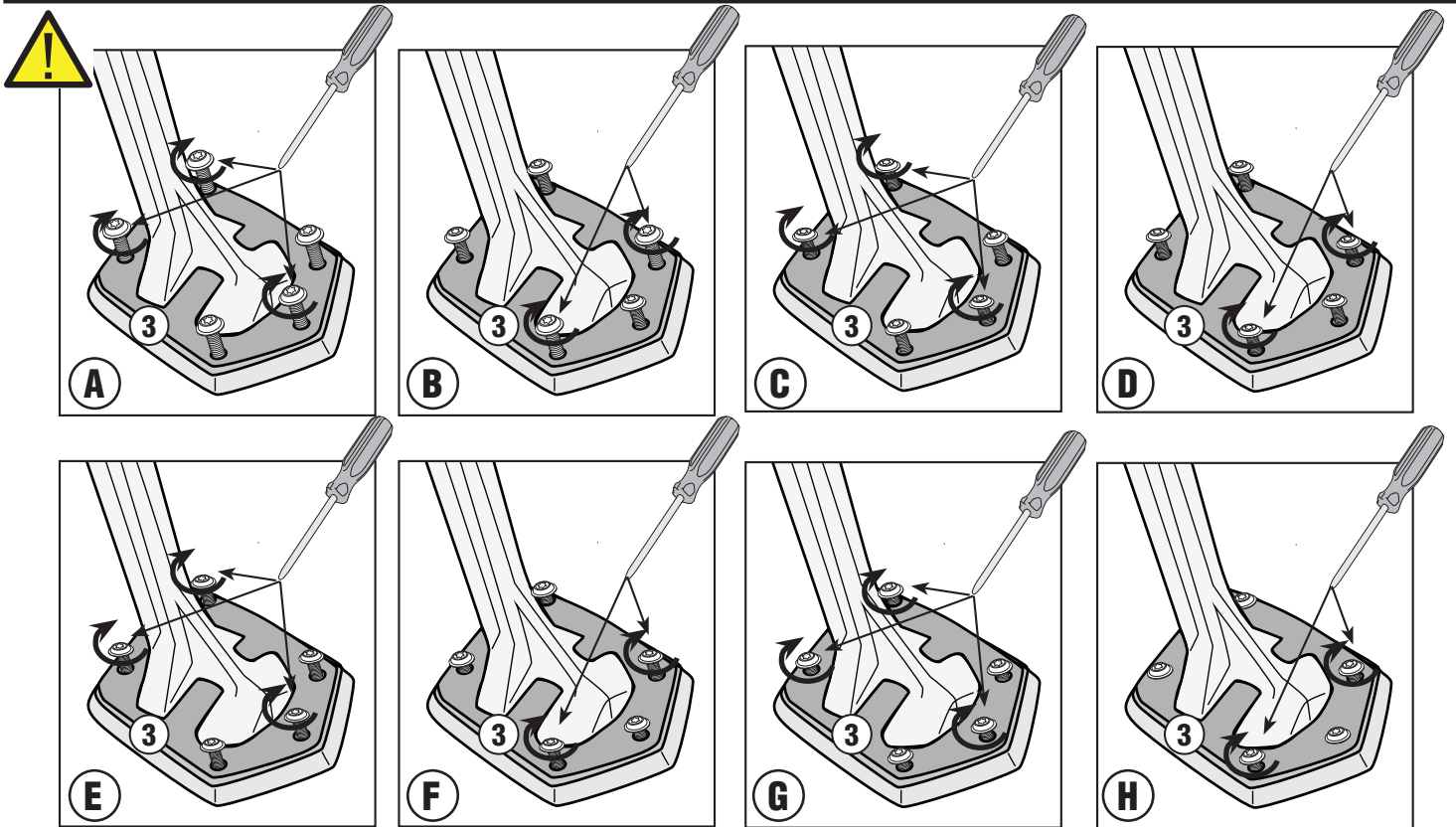

IT Avvitando le 5 viti, il componente N°3 si adatterà alla forma del cavalletto laterale originale.

È però fondamentale che le viti vengano avvitate gradualmente in modo alternato, e non che si stringa fino in fondo una vite, senza procedere con il parziale serraggio delle altre.

EN By using the 5 screws, component No. 3 will adapt to the shape of the original side stand.

However, it is essential that the screws are tightened gradually, in an alternating manner. Do not tighten one screw completely without tightening the others. Tighten them each a little at a time.

DE Durch Anziehen der 5 Schrauben passt sich das Element Nr. 3 der Form des ursprünglichen Seitenständers an.

Wichtig ist dabei, dass Sie alle Schrauben zunächst erst locker eindrehen und dann die Schrauben nach und nach festziehen. Eine Schraube darf erst festgezogen werden, wenn die anderen auch zumindest teilweise angezogen wurden.

FR Lors du vissage des 5 vis, le composant n° 3 s'adapte à la forme de la béquille latérale d'origine.

Il est cependant fondamental que les vis soient vissées progressivement de manière alternée. Une vis ne doit pas être serrée à fond si les autres ne sont pas partiellement serrées.

ES Atornillando los 5 tornillos, el componente N.º3 se adaptará a la forma del caballete lateral original.

Sin embargo, es fundamental atornillar los tornillos de forma gradual y alternada, es decir, no apretando a fondo un tornillo sin antes haber apretado parcialmente los demás.

PT Ao aparafusar os 5 parafusos, o componente N.º 3 se adaptará ao formato do descanso lateral original.

Porém, é essencial que os parafusos sejam aparafusados gradualmente de maneira alternada, e que um parafuso não seja completamente apertado, sem antes realizar o aperto parcial dos outros.

ES2145 - ES2145K

ESTENSIONE CAVALLETTO LATERALE - SIDE STAND EXTENSION - FUSSVERBREITERUNGEN FÜR SEITENSTÄNDER
ZIJSTANDAARD EXTENSIE - EXTENSIÓN DEL CABALLETE LATERAL - EXTENSÃO DO CAVALETE LATERAL

YAMAHA Ténéré 700 (2019)

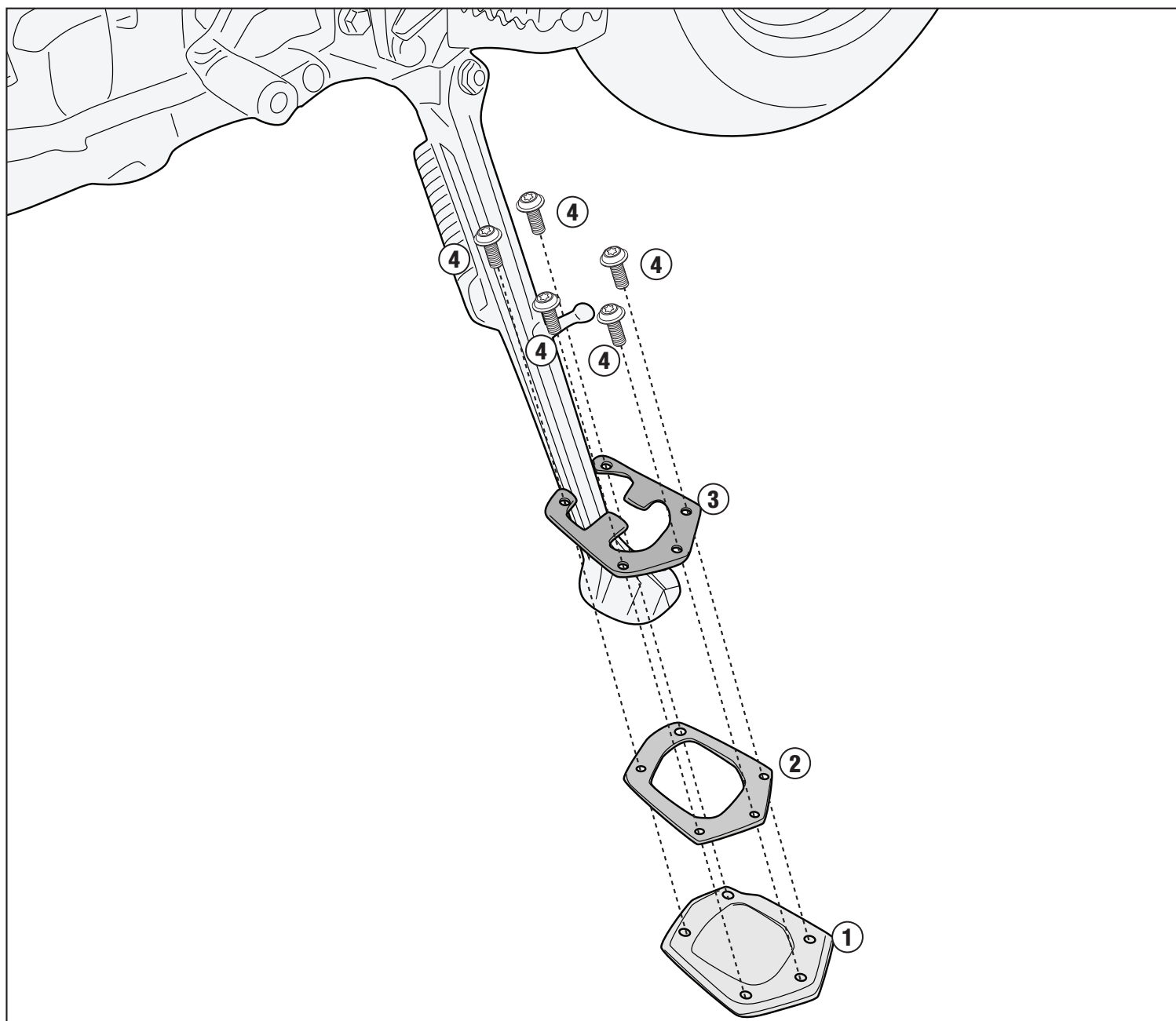
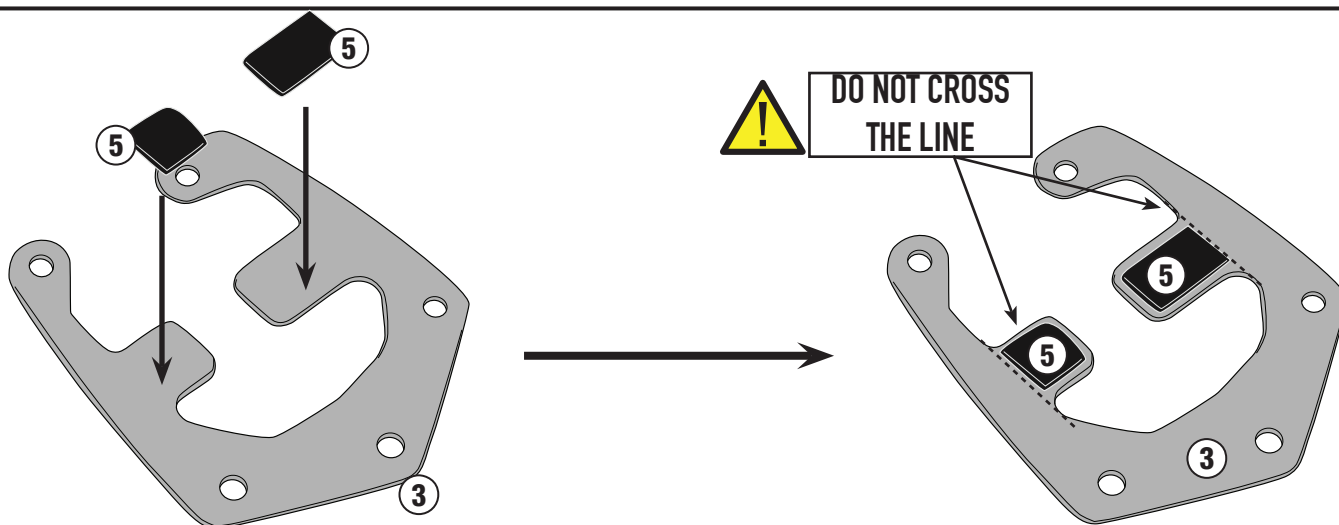

ISTRUZIONI DI MONTAGGIO - MOUNTING INSTRUCTIONS
INSTRUCCIONES DE MONTAJE - BAUANLEITUNG
INSTRUCCIONES DE MONTAJE - INSTRUÇÕES DE MONTAGEM