

PL3105CAM

PORTAVALIGIE LATERALE SPECIFICO - SPECIFIC TUBULAR SIDE-CASE HOLDER - PORTE-VALISES LATÉRAUX SPÉCIFIQUE
 SPEZIFISCHES STAHLROHR-SEITENTRAEGER - PORTA MALETAS LATERALES ESPECÍFICO - TRONCO LADO ESPECÍFICO

SUZUKI DL1000 V-STROM (2014-2016)
SUZUKI DL1000 V-STROM (2017)

N°	Descrizione	Caratteristiche	Codice	Quantità	
1	Supporto - Support - Support Halterung - Soporte - Apoio	-	-	2 (Dx,Sx)	
2	Ponte Posteriore - Rear Bridge - Pont Postérieure Verbindungsrohr - Puente Trasero - Ponte Traseira	-	-	1	
3	Vite - Screw Vis - Schraube Tornillo - Parafuso	TBEI M6x45	645TBEI	4	
4	Vite - Screw Vis - Schraube Tornillo - Parafuso	TECF M8x20	820TECF	4	
5	Vite - Screw Vis - Schraube Tornillo - Parafuso	TEF M6x16	616TEF	2	
6	Dado - Bolt - Ecrou Mutter - Tuerca - Porca	Auto Bloccante Flangiato Ribassato M8	8DADIFN	4	
7	Dado - Bolt - Ecrou Mutter - Tuerca - Porca	Auto Bloccante Flangiato M6	6DADIAFLN	2	
8	Distanziale - Spacer Entretoise - Distanzstueck Distanciador - Espaçador	Ø12x20 Foro 6,5mm	C12L20F6,5T	4	
9	Distanziale - Spacer Entretoise - Distanzstueck Distanciador - Espaçador	Ø12x25 Foro 6,5mm	C12L25F6,5T	4	

PL3105CAM

PORTAVALIGIE LATERALE SPECIFICO - SPECIFIC TUBULAR SIDE-CASE HOLDER - PORTE-VALISES LATÉRAUX SPÉCIFIQUE
SPEZIFISCHES STAHLROHR-SEITENTRAEGER - PORTA MALETAS LATERALES ESPECÍFICO - TRONCO LADO ESPECÍFICO

SUZUKI DL1000 V-STROM (2014-2016)
SUZUKI DL1000 V-STROM (2017)

10	Vite - Screw Vis - Schraube Tornillo - Parafuso	TBEI M6x60	660TBEI	2	
11	Rondella - Washer Rondelle - Scheibe Arandela - Arruela	-	Z1063	8	
12	Vite - Screw Vis - Schraube Tornillo - Parafuso	TBEI M6x40	640TBEI	4	

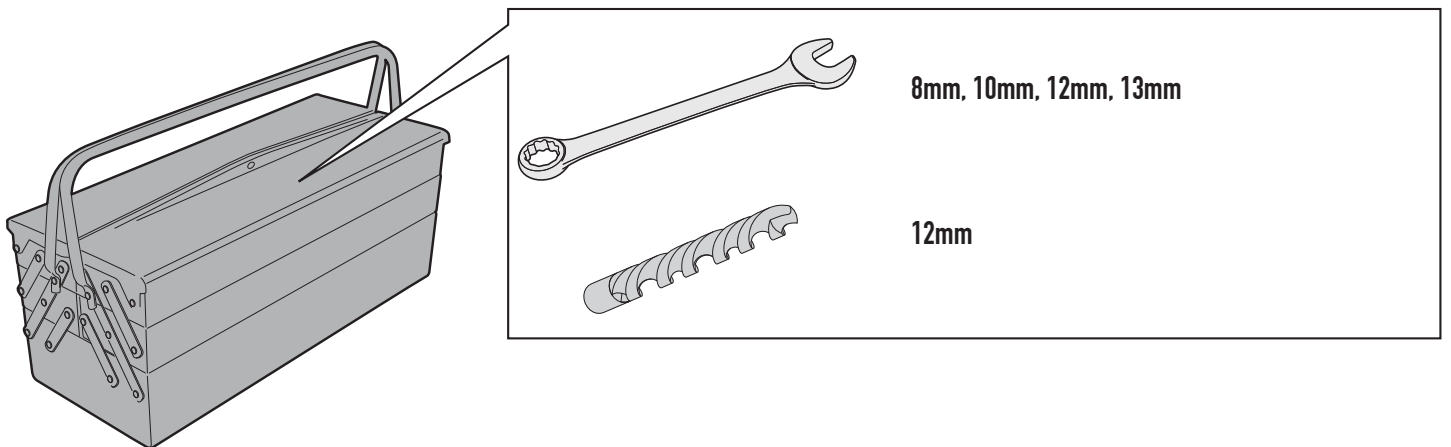

PL3105CAM

PORTAVALIGIE LATERALE SPECIFICO - SPECIFIC TUBULAR SIDE-CASE HOLDER - PORTE-VALISES LATÉRAUX SPÉCIFIQUE
SPEZIFISCHES STAHLROHR-SEITENTRAEGER - PORTA MALETAS LATERALES ESPECÍFICO - TRONCO LADO ESPECÍFICO

SUZUKI DL1000 V-STROM (2014-2016)
SUZUKI DL1000 V-STROM (2017)

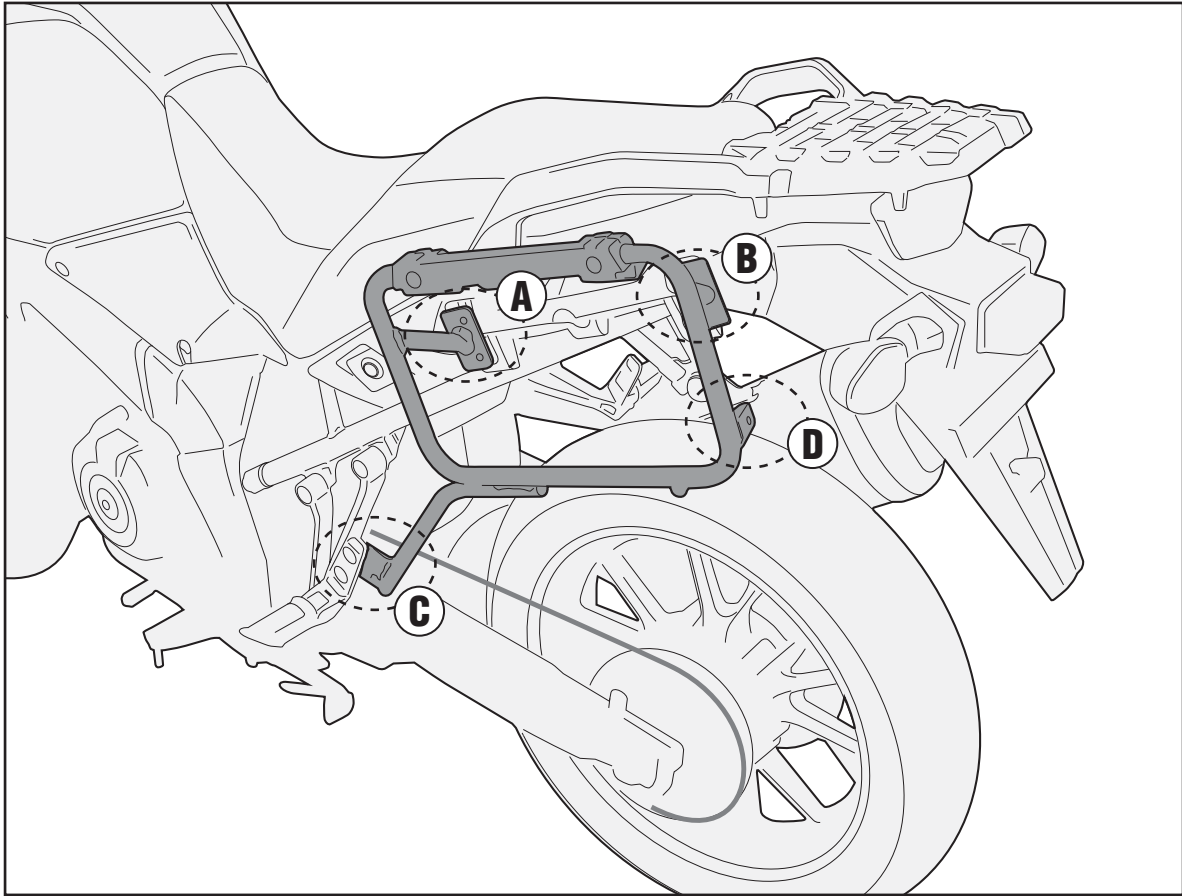

ALLARGARE I FORI CON UNA PUNTA DA 12MM
ENLARGE THE HOLES WITH A Ø12 POINT
AGGRANDIR LES TROUS AVEC UN FORET DE 12MM
DIE LOCHER AUF 12MM AUFBOHREN
AMPLIAR LOS AGUJEROS CON UNA PUNTA DE 12MM
AMPLIAR AGUJERO COM UM POUÇO DE 18 MILÍMETROS

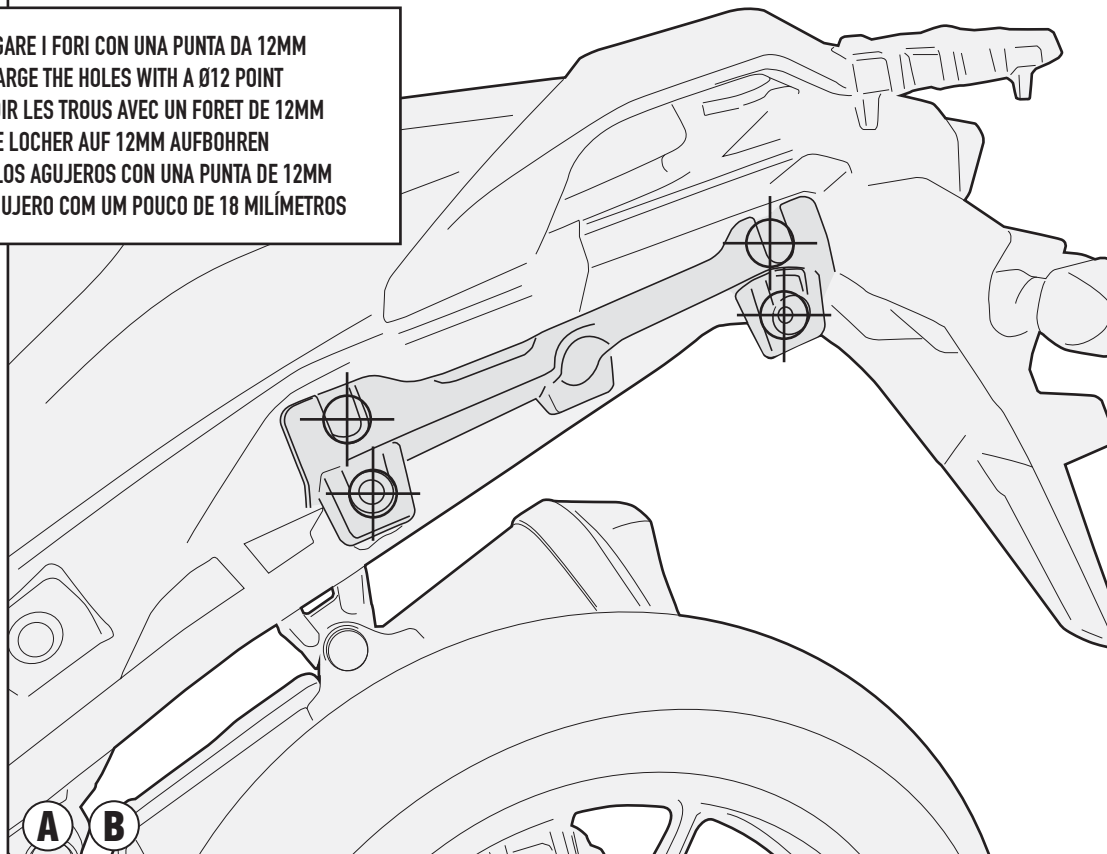

ISTRUZIONI DI MONTAGGIO - MOUNTING INSTRUCTIONS
INSTRUCTIONS DE MONTAGE - BAUANLEITUNG
INSTRUCCIONES DE MONTAJE - INSTRUÇÕES DE MONTAGEM

PL3105CAM

PORTAVALIGIE LATERALE SPECIFICO - SPECIFIC TUBULAR SIDE-CASE HOLDER - PORTE-VALISES LATÉRAUX SPÉCIFIQUE
SPEZIFISCHES STAHLROHR-SEITENTRAEGER - PORTA MALETAS LATERALES ESPECÍFICO - TRONCO LADO ESPECÍFICO

SUZUKI DL1000 V-STROM (2014-2016)
SUZUKI DL1000 V-STROM (2017)

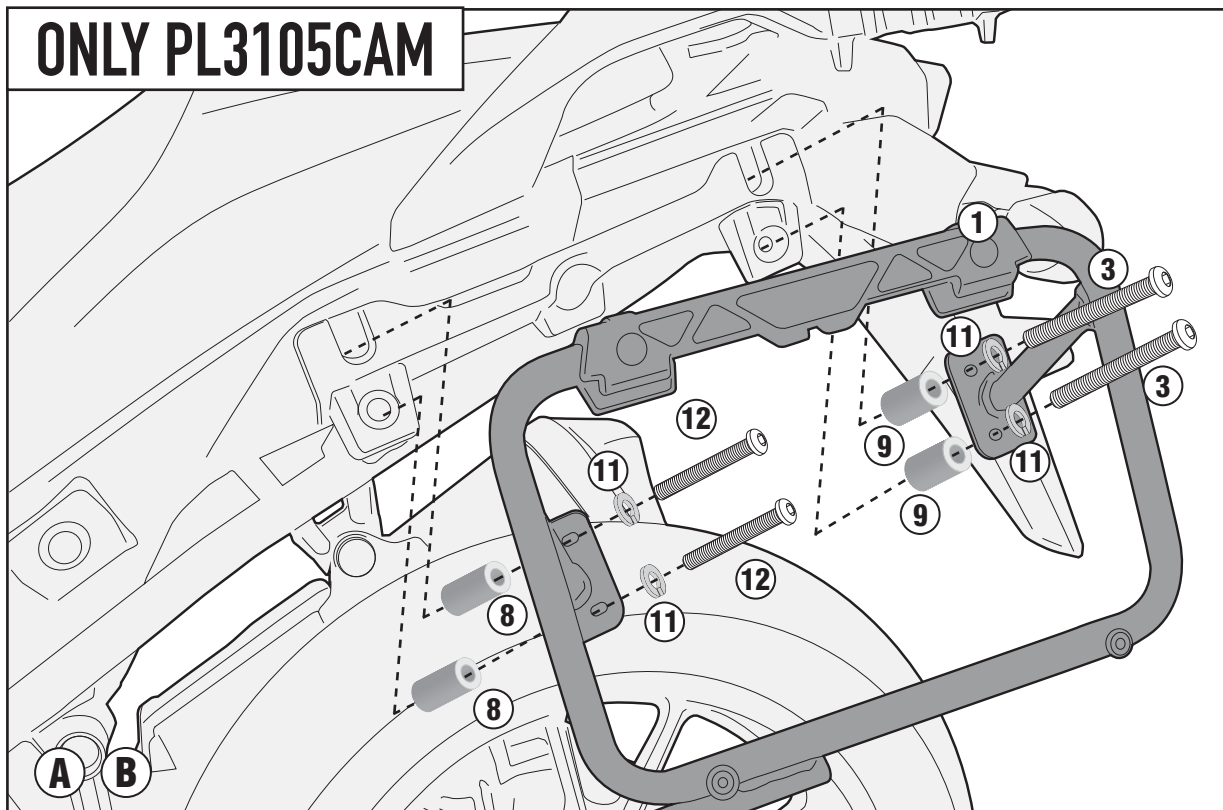

PL03105CAM +SR3105/ SRA3105/ SR3105M/ SR3112/ SRA3112

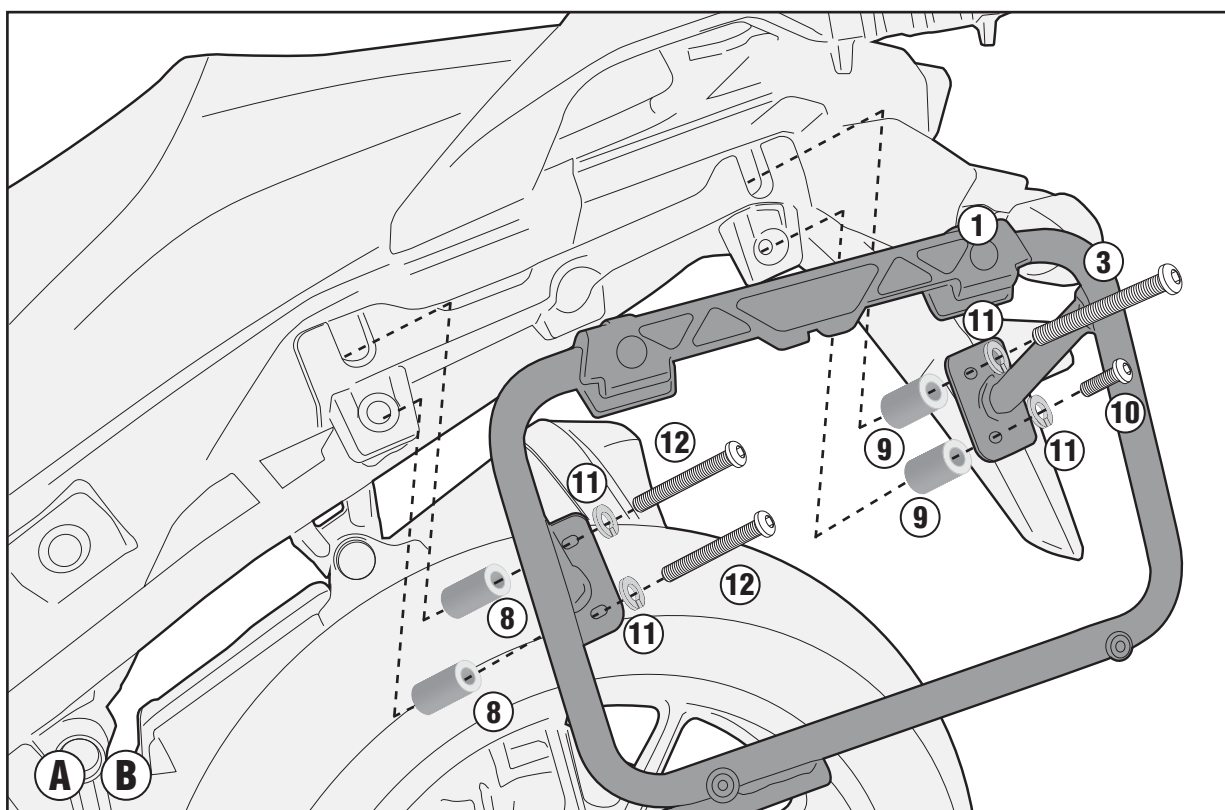

ISTRUZIONI DI MONTAGGIO - MOUNTING INSTRUCTIONS
INSTRUCTIONS DE MONTAGE - BAUANLEITUNG
INSTRUCCIONES DE MONTAJE - INSTRUÇÕES DE MONTAGEM

PL3105CAM

PORTAVALIGIE LATERALE SPECIFICO - SPECIFIC TUBULAR SIDE-CASE HOLDER - PORTE-VALISES LATÉRAUX SPÉCIFIQUE
SPEZIFISCHES STAHLROHR-SEITENTRAEGER - PORTA MALETAS LATERALES ESPECÍFICO - TRONCO LADO ESPECÍFICO

SUZUKI DL1000 V-STROM (2014-2016)
SUZUKI DL1000 V-STROM (2017)

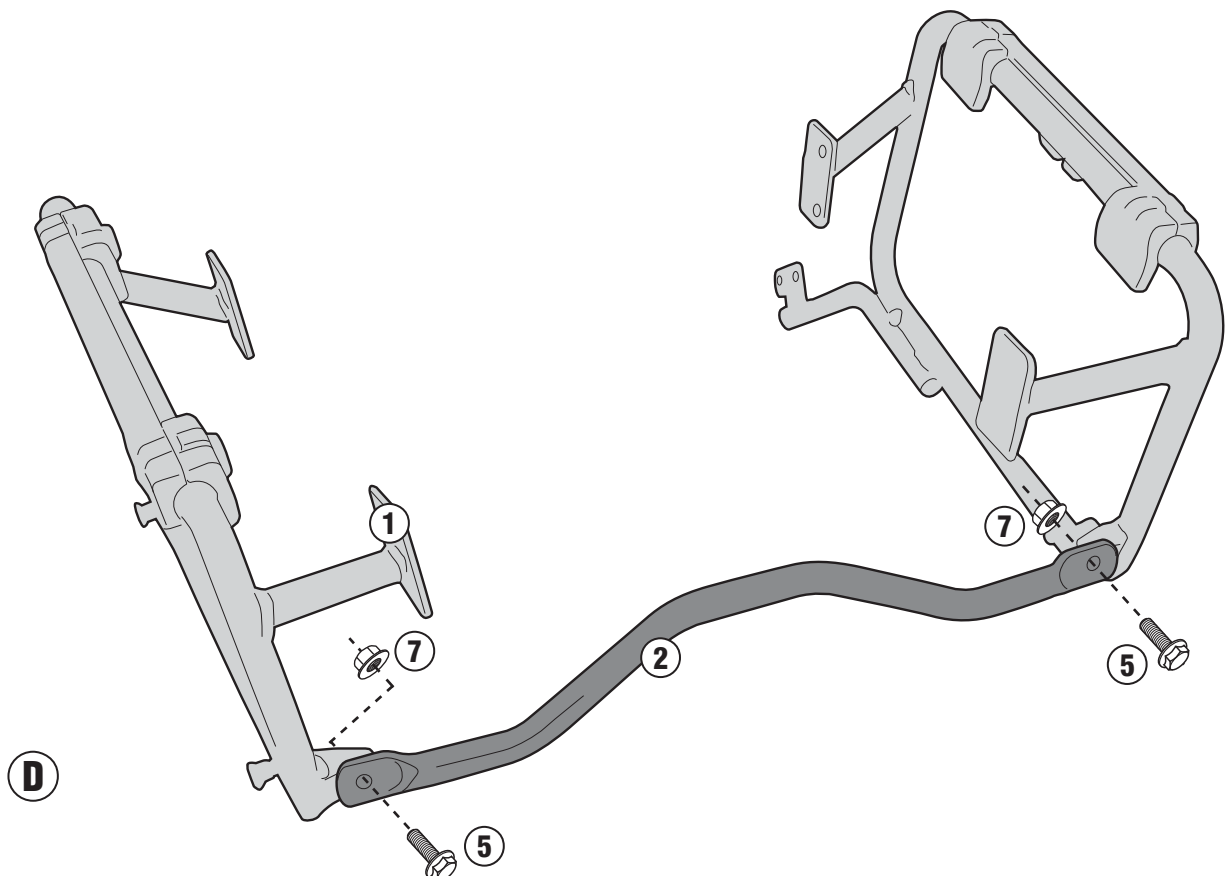
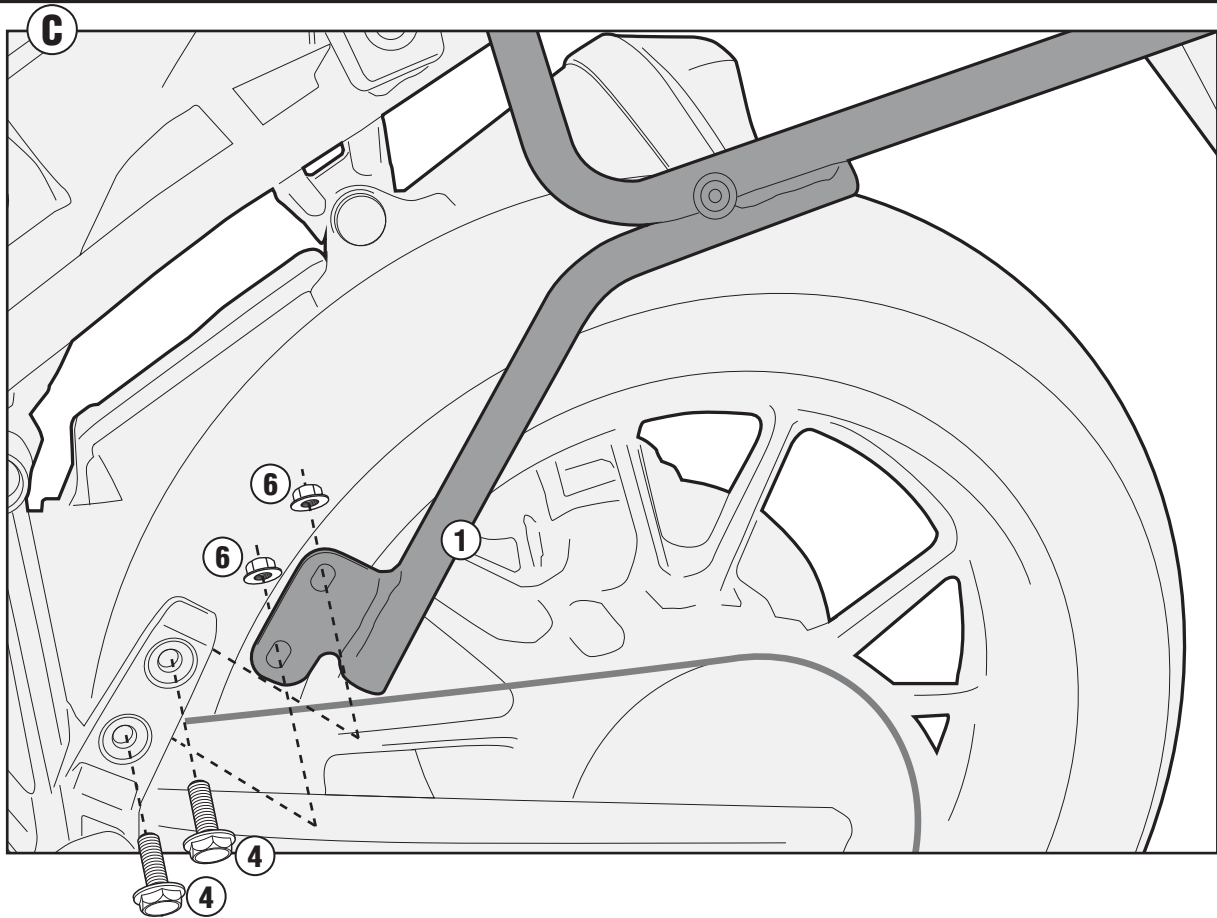

ISTRUZIONI DI MONTAGGIO - MOUNTING INSTRUCTIONS
INSTRUCTIONS DE MONTAGE - BAUANLEITUNG
INSTRUCCIONES DE MONTAJE - INSTRUÇÕES DE MONTAGEM