

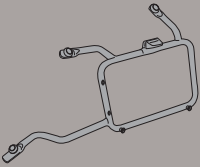

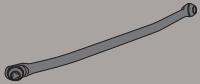

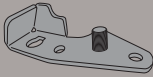



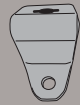
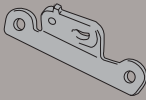

# PLR5108 - KLR5108

PORTAVALIGIE LATERALE SPECIFICO - SPECIFIC TUBULAR SIDE-CASE HOLDER - PORTE-VALISES LATÉRAUX SPÉCIFIQUE  
 SPEZIFISCHES STAHLROHR-SEITENTRAEGER - PORTA MALETAS LATERALES ESPECÍFICO - TRONCO LADO ESPECÍFICO

## BMW R1200GS (2013)

N°	Descrizione	Caratteristiche	Codice	Quantità	
1	Supporto - Support - Support Halteung - Soporte - Apoio	-	-	2 (Dx;Sx)	
2	Ponte Posteriore - Rear Bridge - Pont Postérieure Verbindungsrohr - Puente Trasero - Ponte Traseira	-	-	1	
3	Supporto - Support - Support Halteung - Soporte - Apoio	Sp. 2,5mm	GL2350	2 (Dx;Sx)	
4	Supporto - Support - Support Halteung - Soporte - Apoio	Anteriore - Front Avant - Front Frente - Frente (Sp. 4mm)	GL2367	2 (Dx;Sx)	
5	Supporto - Support - Support Halteung - Soporte - Apoio	Posteriore - Rear Arrière - Rückseite Trasero - Trasero (Sp. 4mm)	GL2366	2 (Dx;Sx)	
6	Supporto - Support - Support Halteung - Soporte - Apoio	Sp. 5mm	GL2365	2 (Dx;Sx)	
7	Vite - Screw Vis - Schraube Tornillo - Parafuso	TBEI M8x35	835TBEI	2	
8	Vite - Screw Vis - Schraube Tornillo - Parafuso	TBEI M8x50	850TBEI	2	
9	Vite - Screw Vis - Schraube Tornillo - Parafuso	TECF M8x40	840TECF	4	
10	Vite - Screw Vis - Schraube Tornillo - Parafuso	TBEIFN M6x16	616TBEIFN	2	
11	Dado - Bolt - Ecrou Mutter - Tuerca - Porca	Auto Bloccante Flangiato M6	6DADIAFLN	2	
12	Rondella - Washer Rondelle - Scheibe Arandela - Arruela	Ø8	814RON	4	
13	Rondella - Washer Rondelle - Scheibe Arandela - Arruela	Ø8x20	820RON	4	

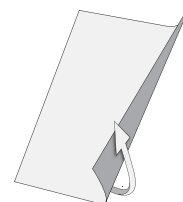

# PLR5108 - KLR5108

PORTAVALIGIE LATERALE SPECIFICO - SPECIFIC TUBULAR SIDE-CASE HOLDER - PORTE-VALISES LATÉRAUX SPÉCIFIQUE  
 SPEZIFISCHES STAHLROHR-SEITENTRAEGER - PORTA MALETAS LATERALES ESPECÍFICO - TRONCO LADO ESPECÍFICO

## BMW R1200GS (2013)

N°	Descrizione	Caratteristiche	Codice	Quantità	
14	Componenti Originali - Original Parts Parties Originales - Original Bauteile Componentes Originales	-	-	-	-
15	Chiave Per Viti A Testa Speciale - Special Key Cle Speciale - Spezialschlüssel Llave Para Tornillos Con Cabeza Especial	-	-	1	
16	Paratia - Bulkhead Cloison - Schott Mamparo - Anteparo	Sp. 2mm	GL2462	1	
17	Supporto - Support - Support Halterung - Soporte - Apoyo	Sp. 1mm	GL2463	3	
18	Vite - Screw Vis - Schraube Tornillo - Parafuso	TBEIF M6x10	610TBEIF	3	
19	Dado - Bolt - Ecrou Mutter - Tuerca - Porca	Dado	6DADIAFL	3	

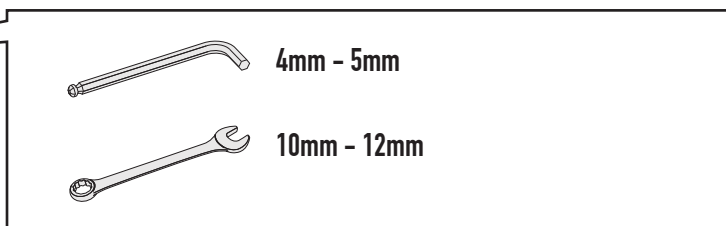
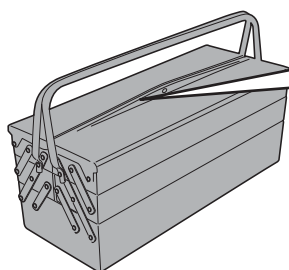
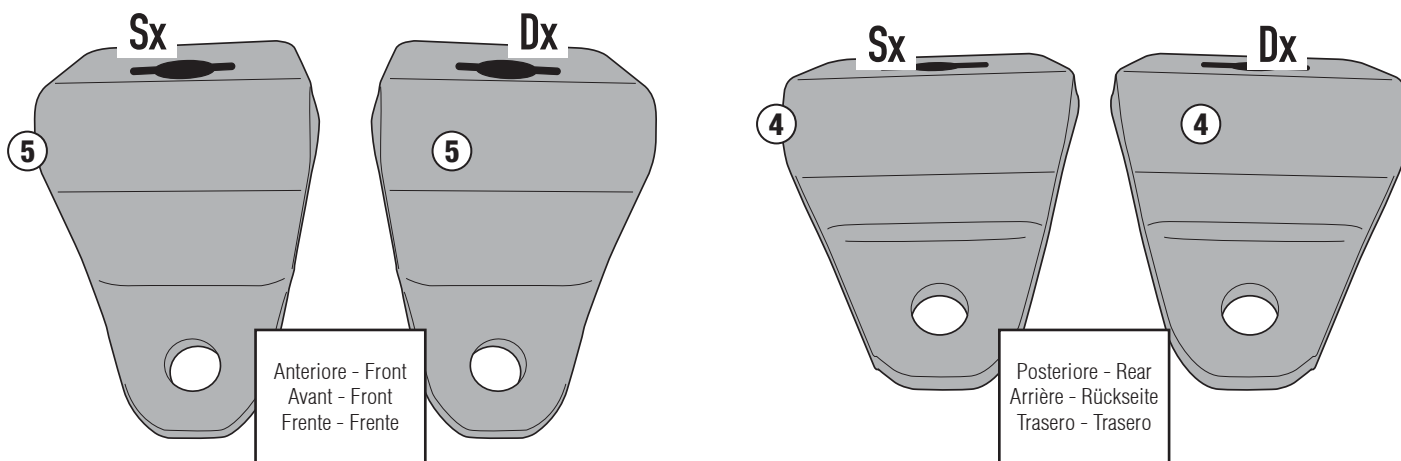

# PLR5108 - KLR5108

PORTAVALIGIE LATERALE SPECIFICO - SPECIFIC TUBULAR SIDE-CASE HOLDER - PORTE-VALISES LATÉRAUX SPÉCIFIQUE  
SPEZIFISCHES STAHLROHR-SEITENTRAEGER - PORTA MALETAS LATERALES ESPECÍFICO - TRONCO LADO ESPECÍFICO

## BMW R1200GS (2013)

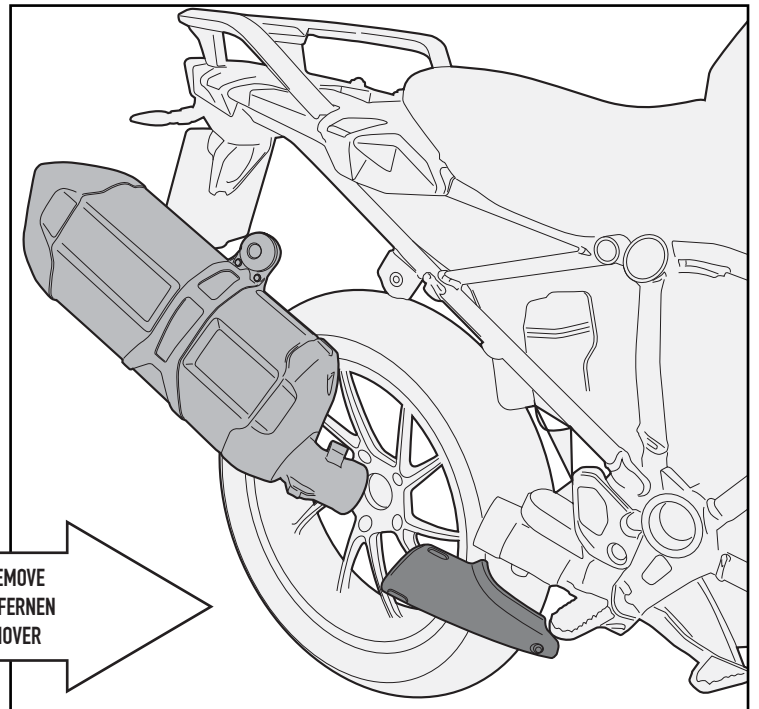
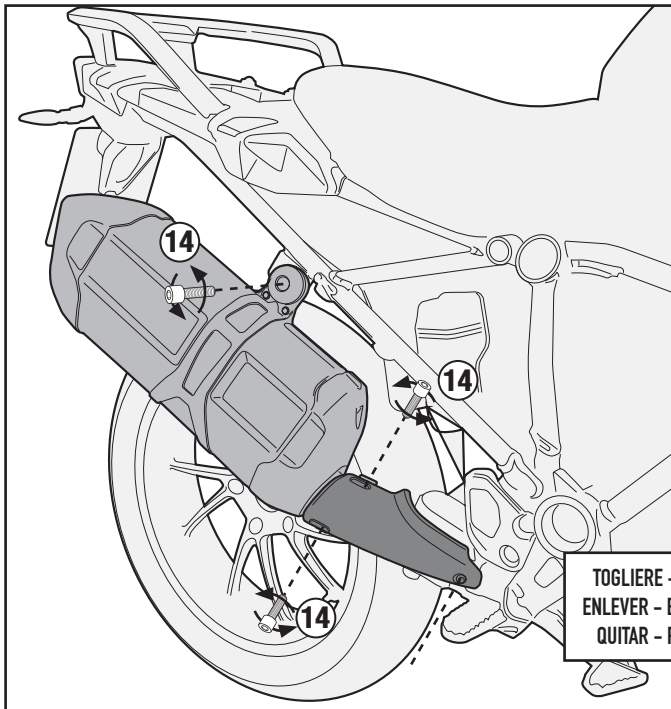
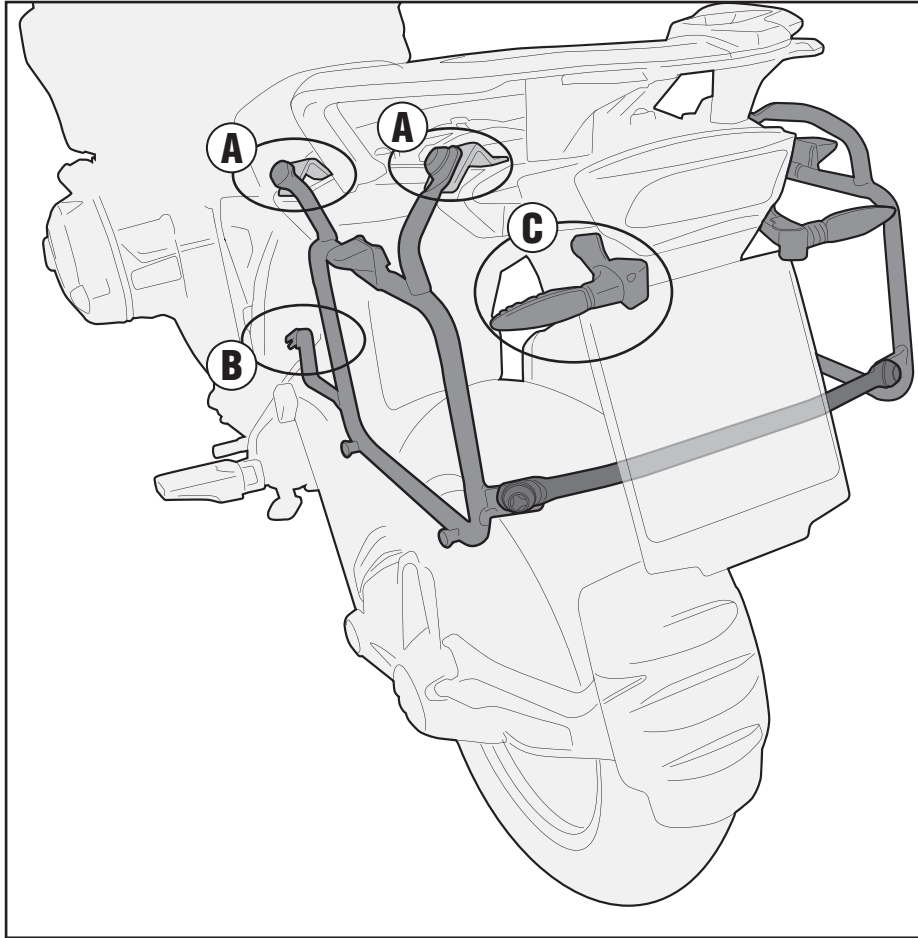

TOGLIERE - REMOVE  
ENLEVER - ENTFERNEN  
QUITAR - REMOVER

# PLR5108 - KLR5108

PORTAVALIGIE LATERALE SPECIFICO - SPECIFIC TUBULAR SIDE-CASE HOLDER - PORTE-VALISES LATÉRAUX SPÉCIFIQUE  
SPEZIFISCHES STAHLROHR-SEITENTRAEGER - PORTA MALETAS LATERALES ESPECÍFICO - TRONCO LADO ESPECÍFICO

## BMW R1200GS (2013)

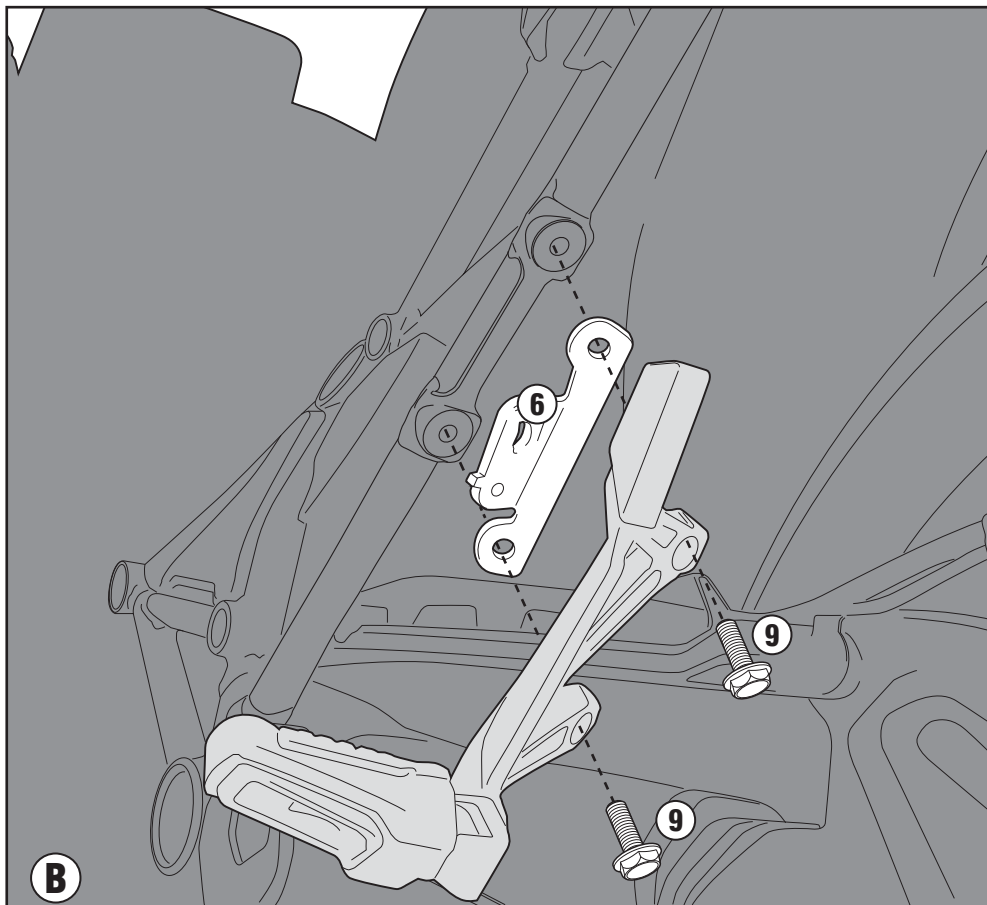
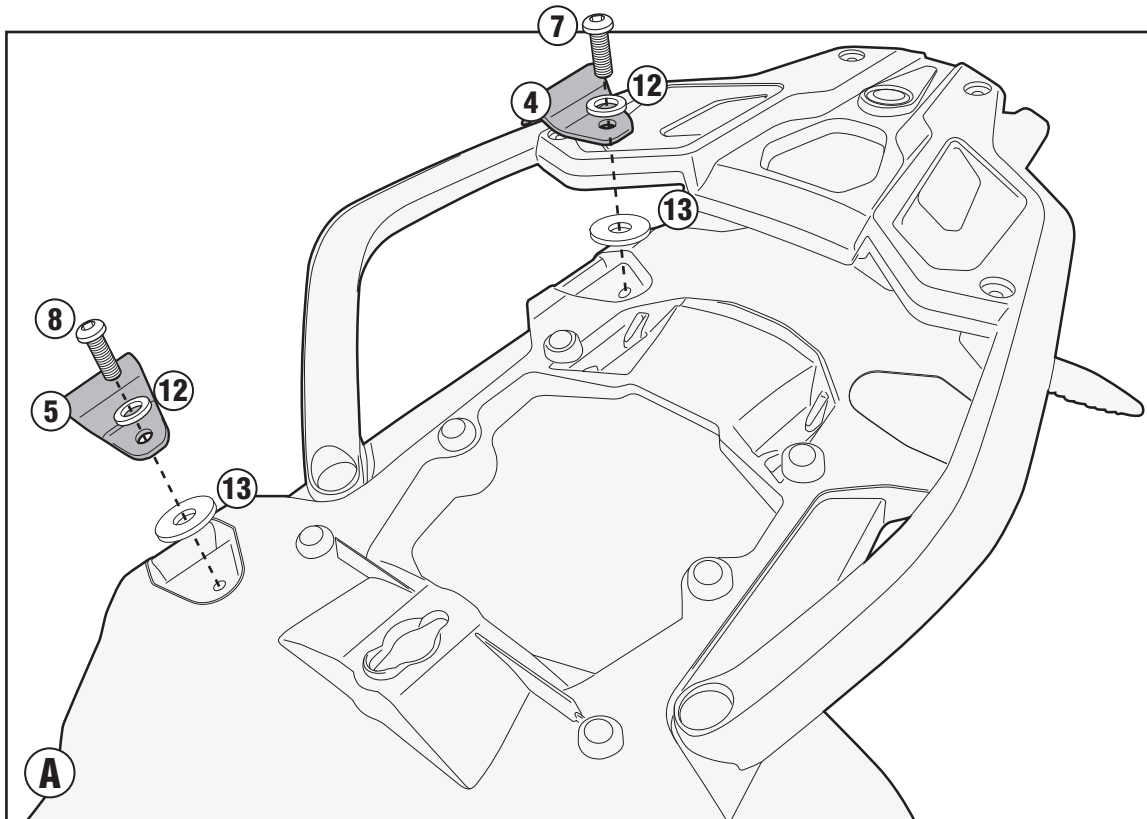

# PLR5108 - KLR5108

PORTAVALIGIE LATERALE SPECIFICO - SPECIFIC TUBULAR SIDE-CASE HOLDER - PORTE-VALISES LATÉRAUX SPÉCIFIQUE  
SPEZIFISCHES STAHLROHR-SEITENTRAEGER - PORTA MALETAS LATERALES ESPECÍFICO - TRONCO LADO ESPECÍFICO

## BMW R1200GS (2013)

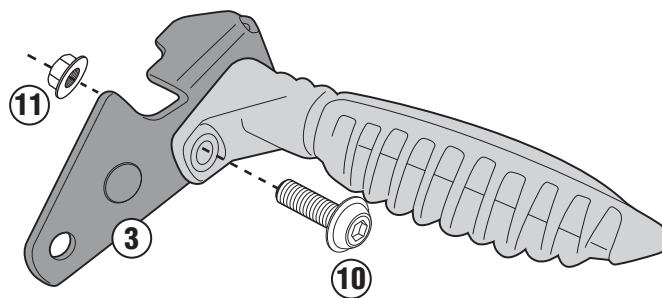
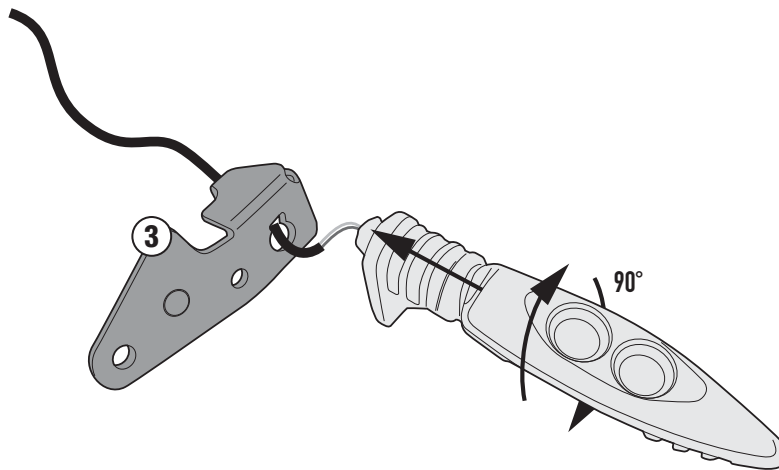
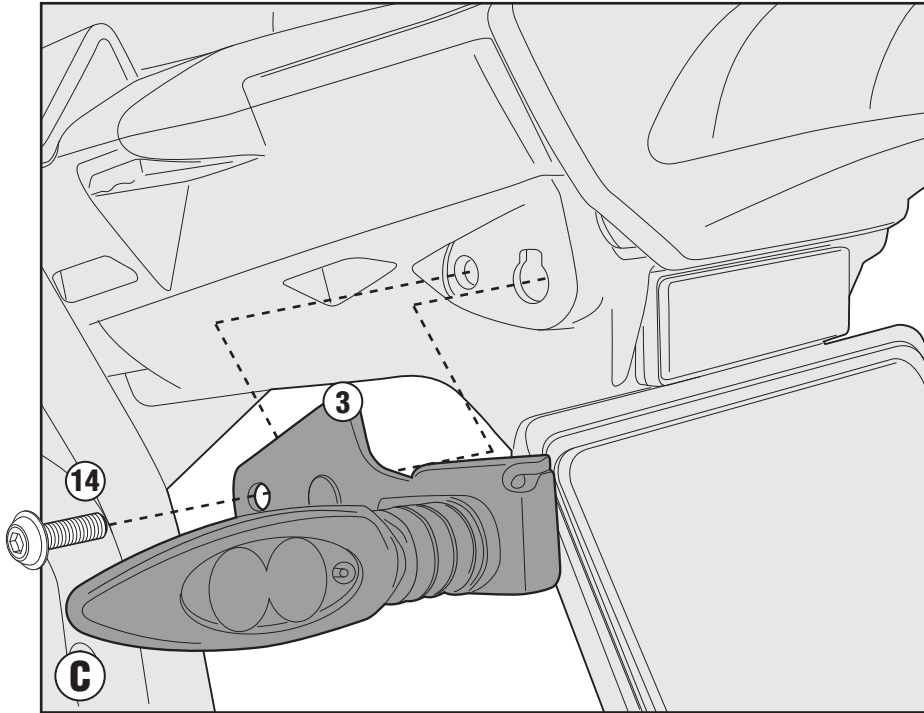

# PLR5108 - KLR5108

PORTAVALIGIE LATERALE SPECIFICO - SPECIFIC TUBULAR SIDE-CASE HOLDER - PORTE-VALISES LATÉRAUX SPÉCIFIQUE  
SPEZIFISCHES STAHLROHR-SEITENTRAEGER - PORTA MALETAS LATERALES ESPECÍFICO - TRONCO LADO ESPECÍFICO

## BMW R1200GS (2013)

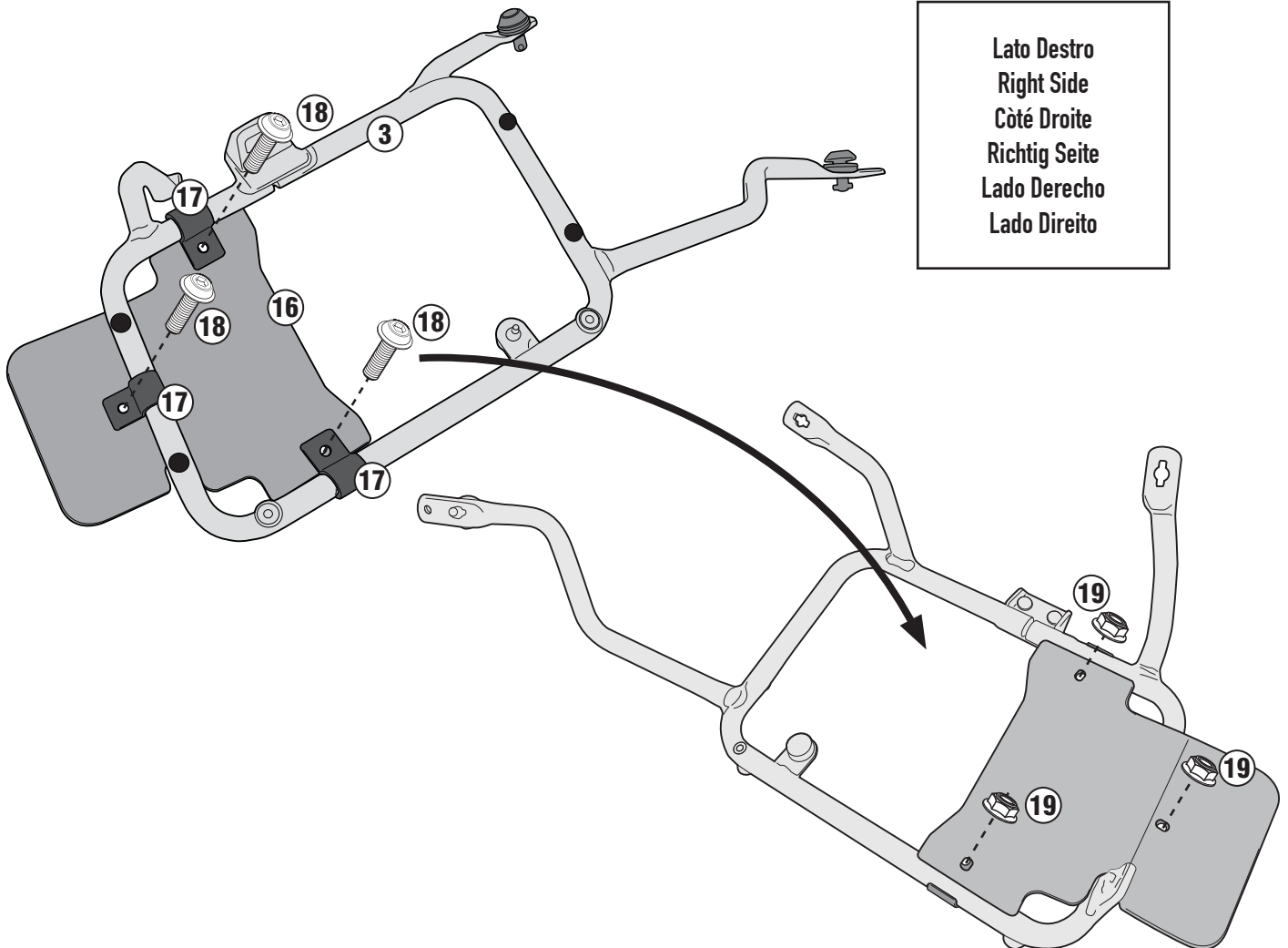
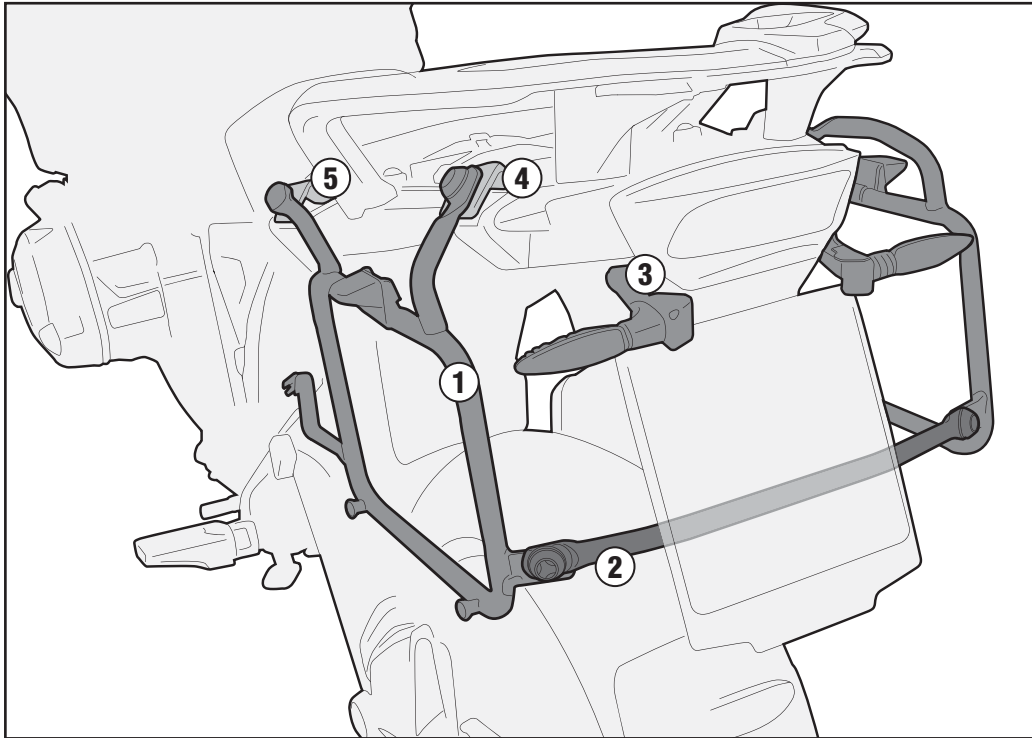

ISTRUZIONI DI MONTAGGIO - MOUNTING INSTRUCTIONS  
INSTRUCTIONS DE MONTAGE - BAUANLEITUNG  
INSTRUCCIONES DE MONTAJE - INSTRUÇÕES DE MONTAGEM

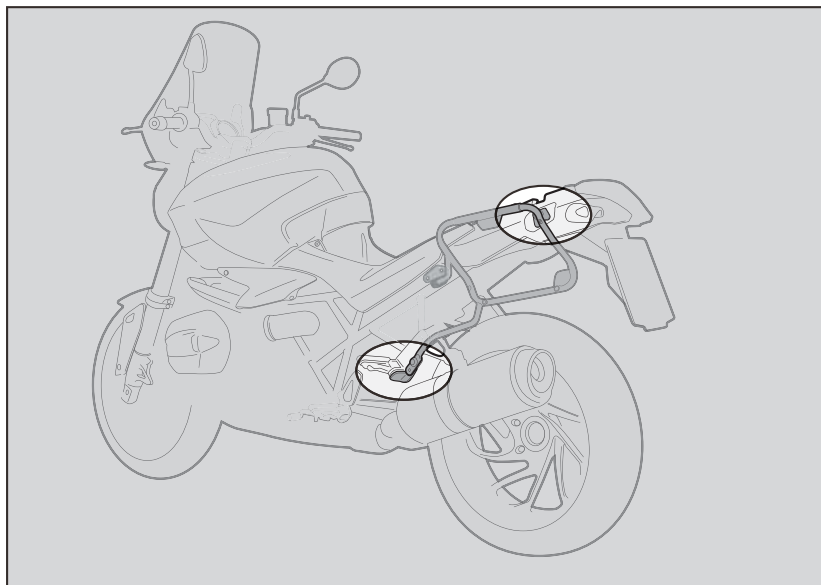

1. INSERIRE L'ATTREZZO NELLA TESTA DELLA VITE SPECIALE;
2. RUOTARE DI 1/4 DI GIRO IN SENSO ORARIO FINO A CHE LA ROTAZIONE NON TERMINA E SI AVVERTE LO SCATTO;
3. PER SMONTARE PROCEDERE IN SENSO INVERSO.

1. INSERT THE SPECIAL KEY INTO THE HEAD OF THE SCREW;
2. TURN THE KEY ¼ TURN CLOCKWISE UNTIL ROTATION STOPS AND THE SIDE CASE HOLDER IS FASTENED SECURELY TO THE FITMENT POINT;
3. IN ORDER TO DISASSEMBLE THE BRACKETRY PERFORM THE OPERATION IN REVERSE.

1. INSERER LA CLE SPECIALE DANS LA TÊTE DE LA VIS;
2. VISSER D'1/4 DE TOUR DANS LE SENS HORAIRE JUSQU'AU BLOCAGE DE LA VIS POUR MONTER EN TOUTE SECURITE LE SUPPORT A SON POINT DE FIXATION;
3. POUR LE DEMONTAGE, PROCEDER EN SENSE INVERSE.

1. STECKEN SIE DAS WERKZEUG IN DEN KOPF DER SPEZIFISCHEN SCHRAUBE;
2. DREHEN SIE DIE SCHRAUBE 1 / 4 UMDREHUNG IM UHRZEIGERSINN BIS SIE BEMERKEN, DASS DIE SCHRAUBE IM BEFESTIGUNGSPUNKT EINGEKLEMMT IST;
3. FÜR DIE DEMONTAGE FOLGEN SIE DEN HINWEISE UMGEKEHRT.

1. INSERTAR LA LLAVE ESPECIAL EN LA CABEZA DEL TORNILLO
2. DAR ¼ DE VUELTA EN EL SENTIDO HORARIO HASTA QUE LLEGUE AL TOPE Y SE VEA EL TORNILLO;
3. PARA DESMONTARLO PROCEDER EN LA DIRECCIÓN CONTRARIA;

**MONTAGGIO - ASSEMBLY - MONTAGE - MONTAGE - MONTAJE**

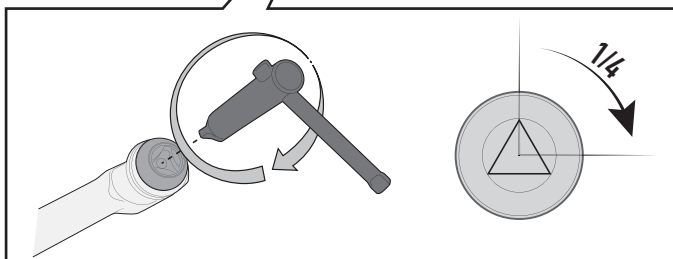
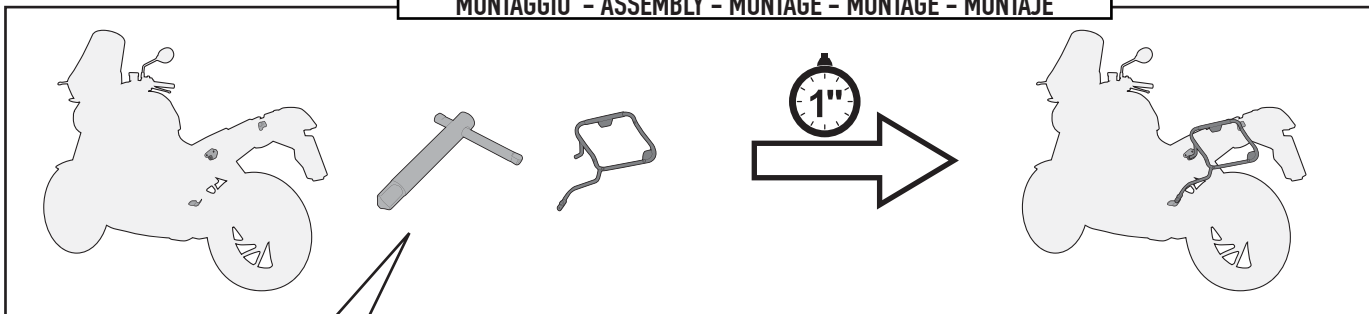

**SMONTAGGIO - DISASSEMBLY - DÉMONTAGE - DEMONTAGE - DESMONTAJE**

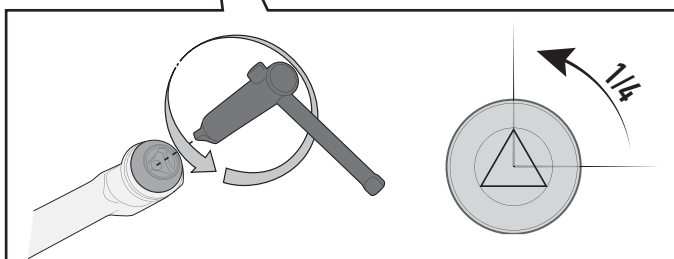
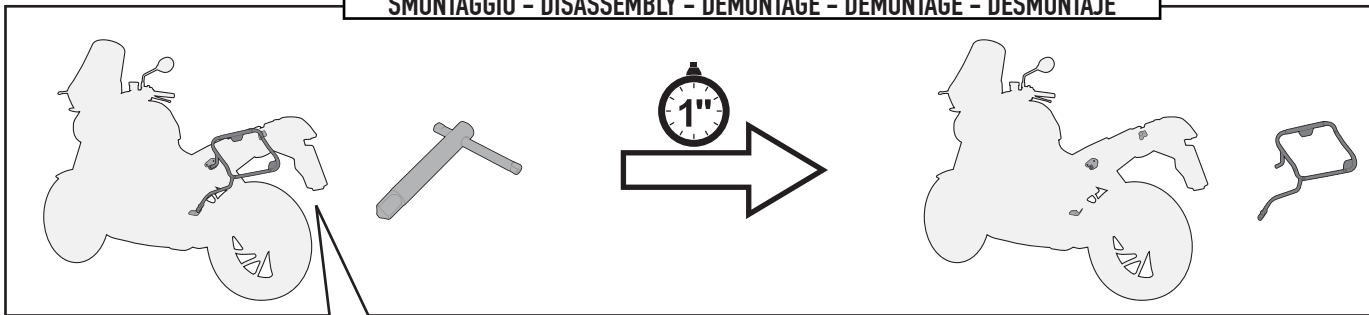



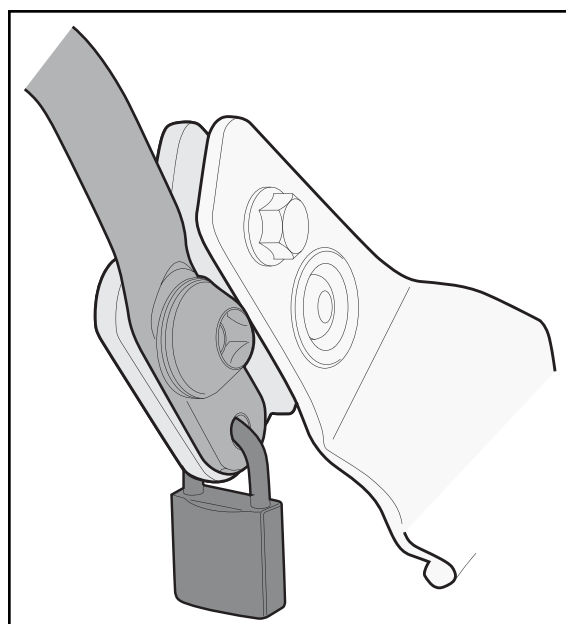
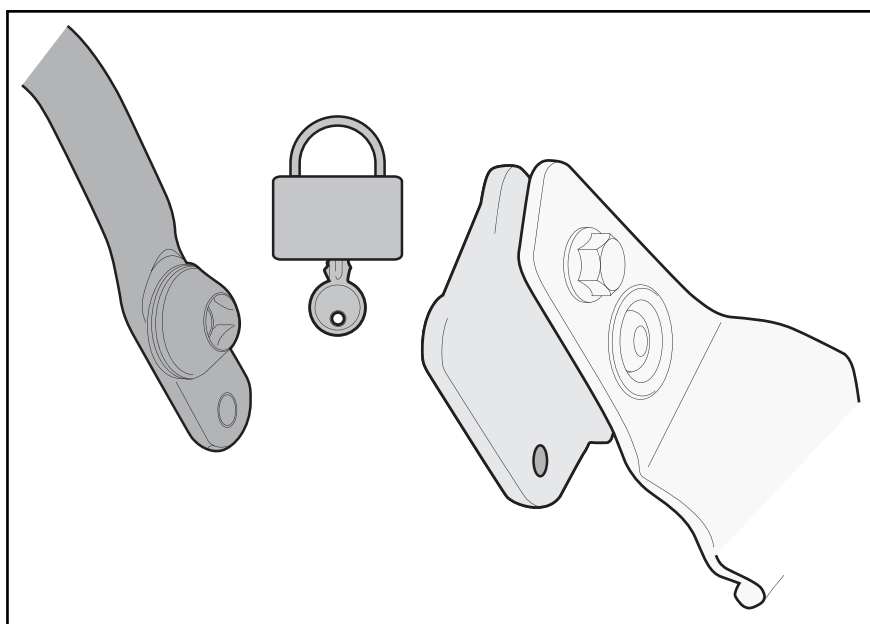
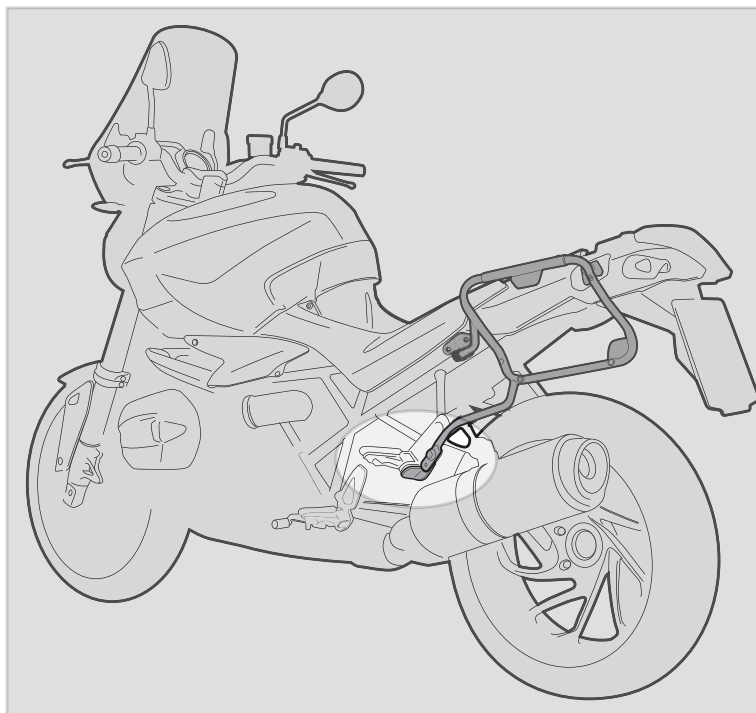

#### **FORO DI SICUREZZA**

FORO PREDISPOSTO AD ASSICURARE IL PORTAVALIGIE LATERALE ALLA MOTO (CON UN LUCCHETTO PER ESEMPIO, NON INCLUSO).

#### **SECURITY HOLE**

HOLE PLACEMENT IN ORDER TO INCREASE SECURITY OF THE TUBULAR SIDE-CASE HOLDER TO THE MOTORCYCLE (WITH A LOCK, FOR EXAMPLE, NOT INCLUDED).

#### **TROU DE SECURITE**

TROU PREDISPOSE POUR ASSURER LE PORTE-VALISE LATERAL A LA MOTO (AVEC UN CADENAS PAR EXEMPLE, NON INCLUS).

#### **SICHERHEITSLÖCH**

VORGEGEHENES LOCH UM DEN SEITENKOFFER TRÄGER AN DEM FAHRZEUG ZU SICHERN (Z. B. MIT EINEM VORHÄNGESCHLOSS, NICHT ENTHALTEN);

#### **ORIFICIO DE SEGURIDAD**

ESTE ORIFICIO ESTA CREADO PARA ASEGURAR EL PORTAEQUIPAJES LATERAL A LA MOTO (POR EJEMPLO CON UN CANDADO, QUE NO ESTÁ INCLUIDO).