

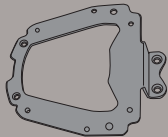









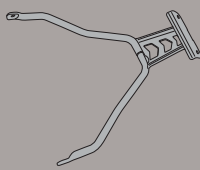

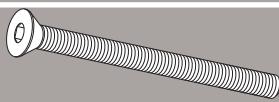

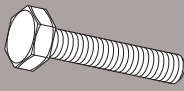
SR2138 - KR2138

PORTAPACCO SPECIFICO - SPECIFIC HOLDER - PORTE-PAQUET SPÉCIFIQUE - SPEZIFISCHER TRÄGER - PORTA-EQUIPAJE ESPECÍFICO - TRANSPORTADOR ESPECÍFICO

YAMAHA X-MAX 400 (2018)

N°	Descrizione	Caratteristiche	Codice	Quantità	
1	Supporto superiore - Higher Support Support supérieur- Halterung höher Soporte superior - Apoio superior	Sp. 3mm	GL3620V	1	
2	Supporto Centrale - Central support Support centrale - Soportem Central Halterung Zentrale - Suporte Central	Sp. 4mm	GL3619V	1	
3	Supporto Inferiore - Lower Support Support Inferieur - Untere Halterung Soporte De Apoyo	-	GNB2140V	1	
4	Vite - Screw Vis - Schraube Tornillo - Parafuso	TBEI M8x20	820TBEI	2	
5	Vite - Screw Vis - Schraube Tornillo - Parafuso	TBEI M6x20	620TBEI	2	
6	Vite - Screw Vis - Schraube Tornillo - Parafuso	TSP M8x75	875TSP	2	
7	Vite - Screw Vis - Schraube Tornillo - Parafuso	TSP M6x16	616TSP	2	
8	Vite - Screw Vis - Schraube Tornillo - Parafuso	TES M10x45	1045TES	1	
9	Dado - Bolt - Ecrou Mutter - Tuerca - Porca	Dado Auto Bloccante Flangiato M8	8DADIFN	2	
10	Dado - Bolt - Ecrou Mutter - Tuerca - Porca	Auto Bloccante Flangiato Ribassato M6	6DADIABFN	4	
11	Dado - Bolt - Ecrou Mutter - Tuerca - Porca	Auto Bloccante Flangiato Alto M6	6DADIAFLN	2	
12	Distanziale - Spacer Entretoise - Distanzstueck Distanciador - Espaçador	Ø10x2 Foro 6,5mm	C10L2F6,5T	2	
13	Distanziale - Spacer Entretoise - Distanzstueck Distanciador - Espaçador	Ø20x50 Foro 16mm	C20L50F16FET	2	
14	Rondella - Washer Rondelle - Scheibe Arandela - Arruela	-	814RON	2	
15	Rondella - Washer Rondelle - Scheibe Arandela - Arruela	-	618RON	2	

SR2138 - KR2138

PORTAPACCO SPECIFICO - SPECIFIC HOLDER - PORTE-PAQUET SPÉCIFIQUE - SPEZIFISCHER TRÄGER - PORTA-EQUIPAJE ESPECÍFICO - TRANSPORTADOR ESPECÍFICO

YAMAHA X-MAX 400 (2018)

N°	Descrizione	Caratteristiche	Codice	Quantità	
16	Rondella - Washer Rondelle - Scheibe Arandela - Arruela	-	10RON	2	
17	Vite - Screw Vis - Schraube Tornillo - Parafuso	TSP M6X20	620TSP	2	
18	Vite - Screw Vis - Schraube Tornillo - Parafuso	TCEI M6X25	625TCEI	2	
19	Componenti Originali - Original Parts Parties Originales - Original Bauteile Componentes Originales - Componentes Originais	-	-	-	-
20	Particolari Inclusi Nel Kit Viteria Della Piastra Components Included In The Fitting Kit Of The Plate Pièces Incluses Dans Le Kit De Vis De La Platine Die Einzelnen Teile Sind Bei Montagekit Der Platte Enthalten Despieces Incluidos En El Kit De Anclajes De La Parrilla Explodiu incluido no Kit as âncoras da grelha	-	-	-	-
21	Vite - Screw Vis - Schraube Tornillo - Parafuso	TES M10X60	1060TES	1	
22	Distanziale - Spacer Entretoise - Distanzstueck Distanciador - Espaçador	Ø22x12 Foro 10,5mm	C22L12F10,5T	1	
23	Rondella - Washer Rondelle - Scheibe Arandela - Arruela	-	101RON	1	
24	Rondella - Washer Rondelle - Scheibe Arandela - Arruela	-	6RON	2	

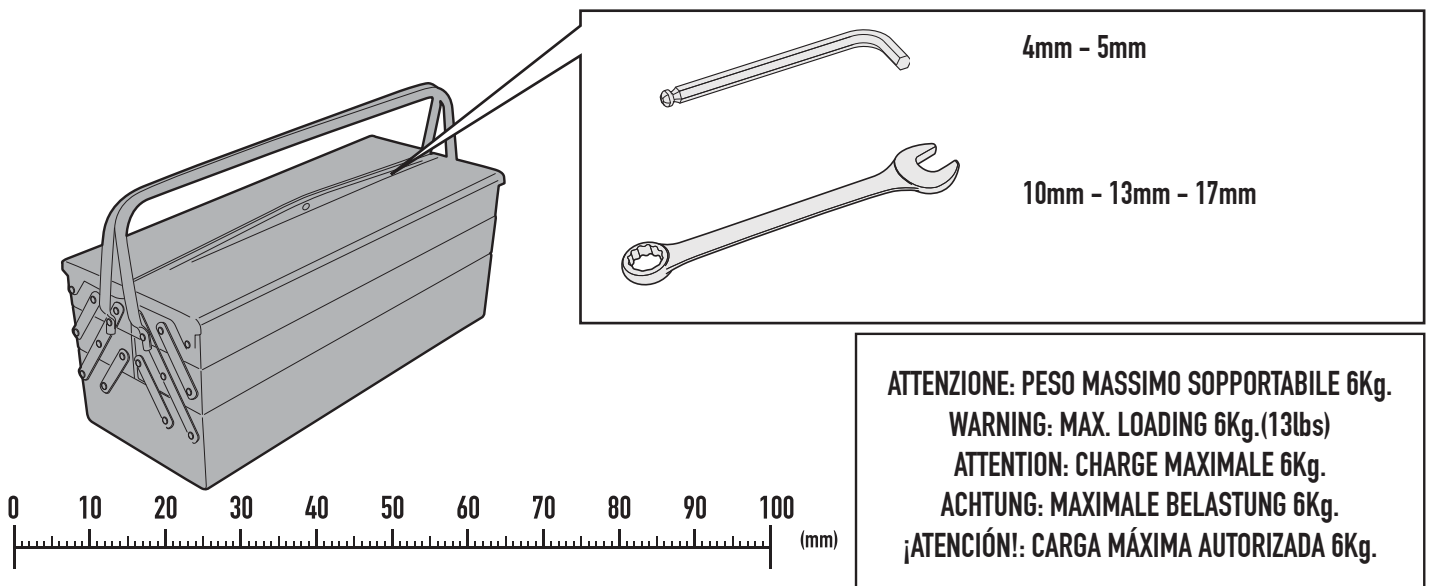

ISTRUZIONI DI MONTAGGIO - MOUNTING INSTRUCTIONS
 INSTRUCTIONS DE MONTAGE - BAUANLEITUNG
 INSTRUCCIONES DE MONTAJE - INSTRUÇÕES DE MONTAGEM

SR2138 - KR2138

PORTAPACCO SPECIFICO - SPECIFIC HOLDER - PORTE-PAQUET SPÉCIFIQUE - SPEZIFISCHER TRÄGER - PORTA-EQUIPAJE ESPECÍFICO - TRANSPORTADOR ESPECÍFICO

YAMAHA X-MAX 400 (2018)

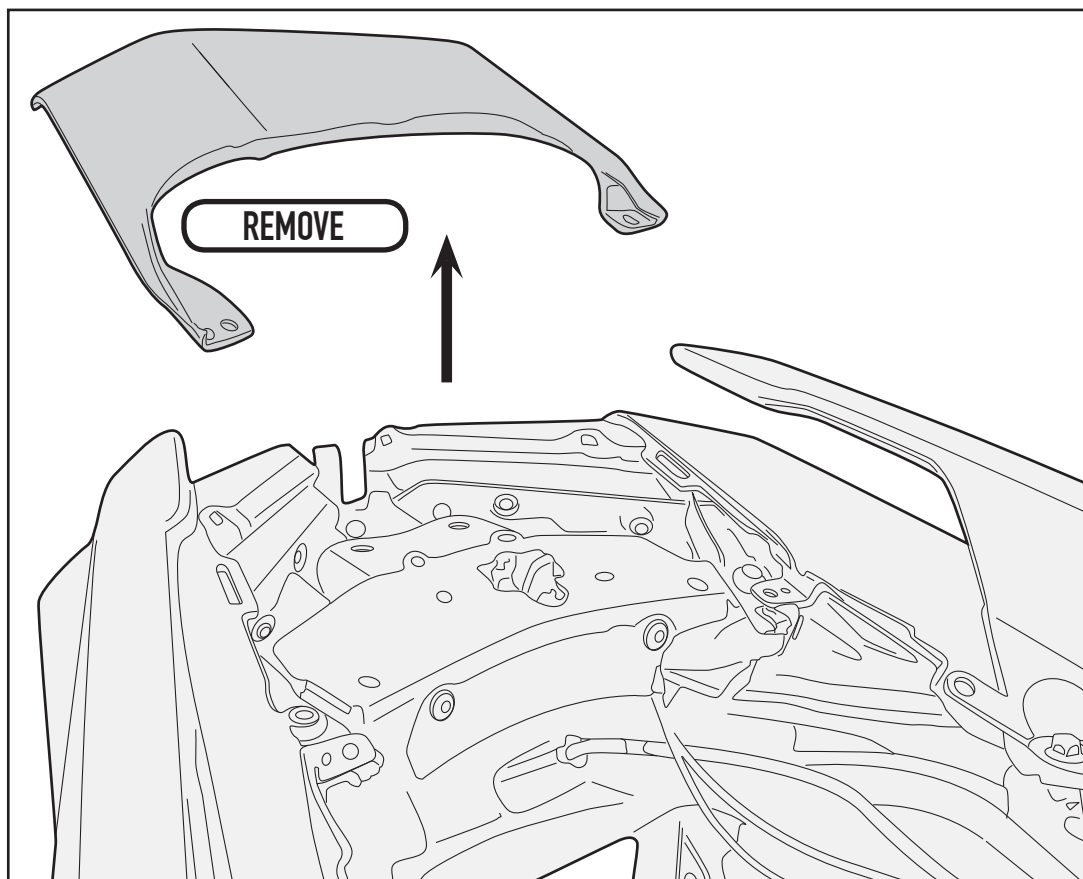
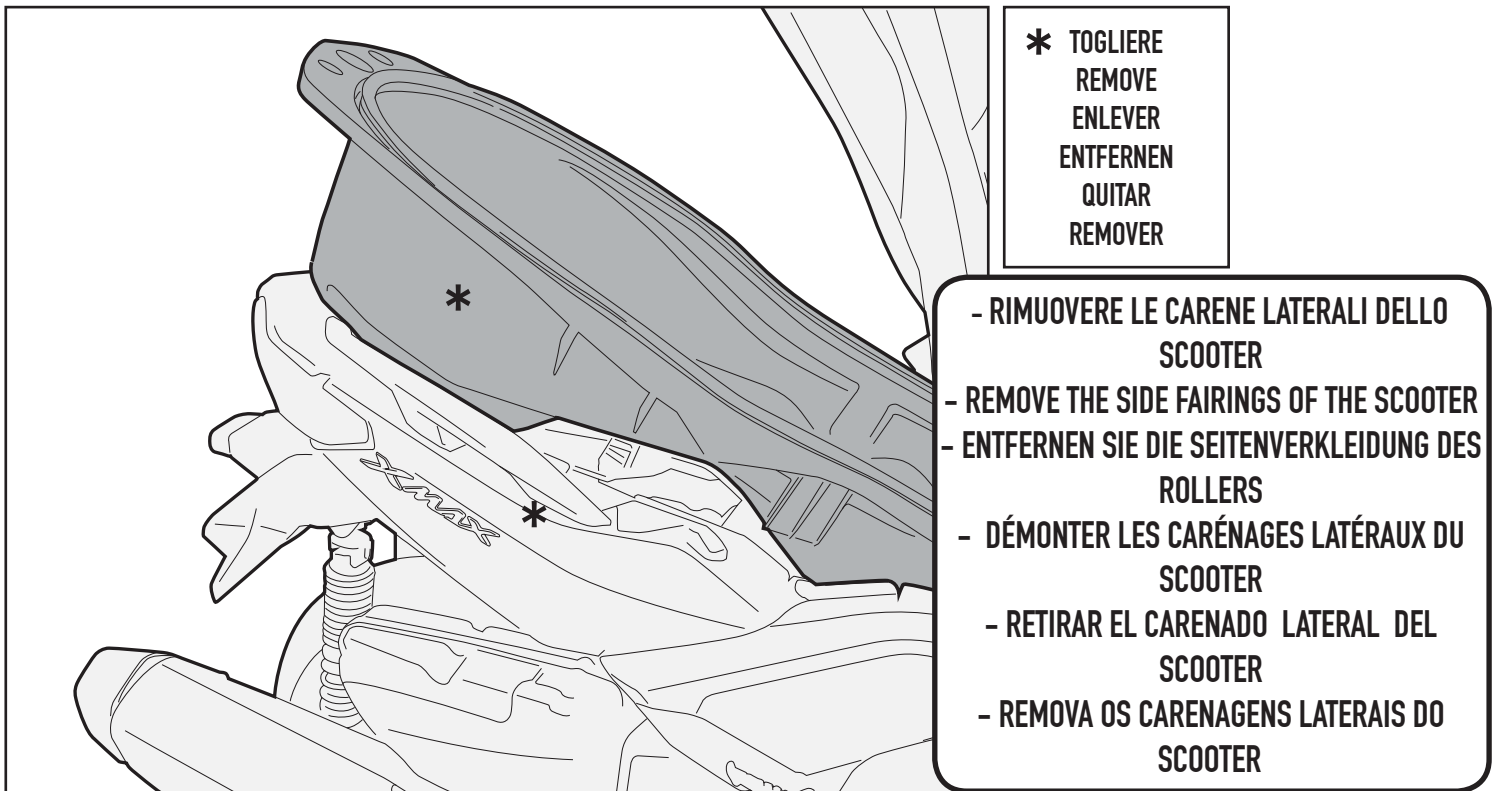

SR2138 - KR2138

PORTAPACCO SPECIFICO - SPECIFIC HOLDER - PORTE-PAQUET SPÉCIFIQUE - SPEZIFISCHER TRÄGER - PORTA-EQUIPAJE ESPECÍFICO - TRANSPORTADOR ESPECÍFICO

YAMAHA X-MAX 400 (2018)

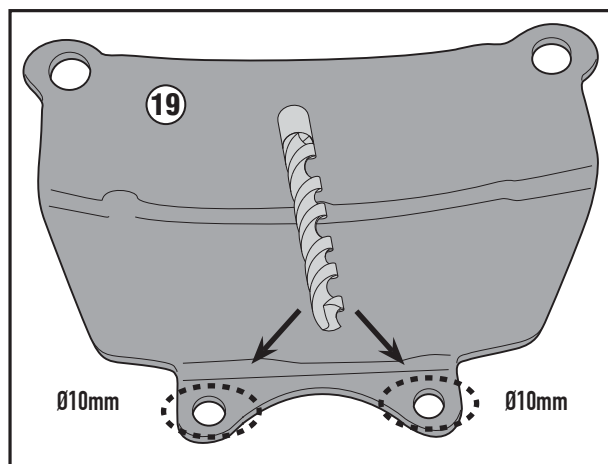

Allargare il foro fino ad un diametro di 10mm.
Widen the hole to a diameter of 10mm.
Erweitern Sie die Bohrungen bis zum endgültigen Durchmesser von 10 mm.
Percer au diamètre de 10mm.
Alargar o furo para um diâmetro de 10 milímetros.
Abrir el agujero hasta un diámetro de 10mm.

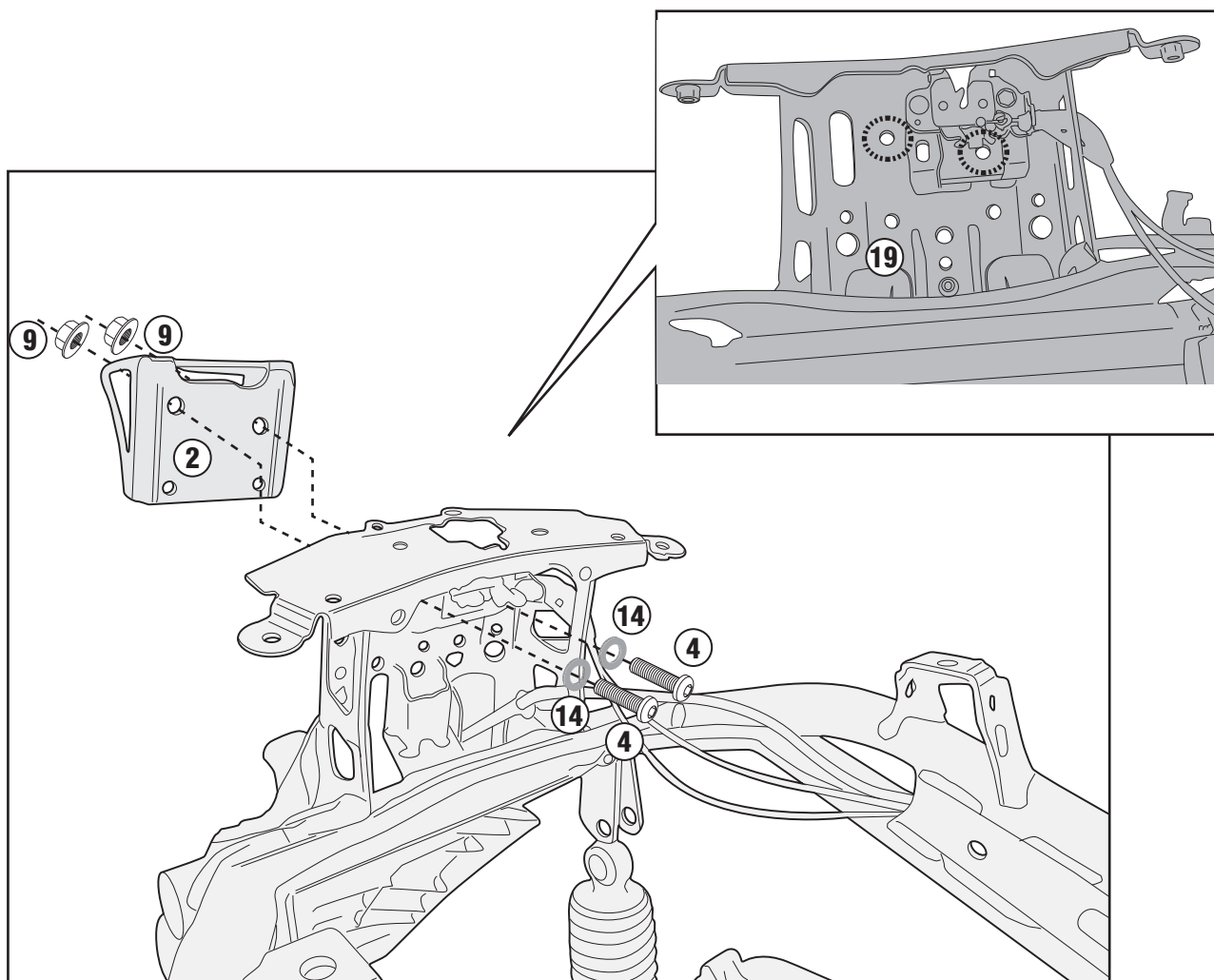

SR2138 - KR2138

PORTAPACCO SPECIFICO - SPECIFIC HOLDER - PORTE-PAQUET SPÉCIFIQUE - SPEZIFISCHER TRÄGER - PORTA-EQUIPAJE ESPECÍFICO - TRANSPORTADOR ESPECÍFICO

YAMAHA X-MAX 400 (2018)

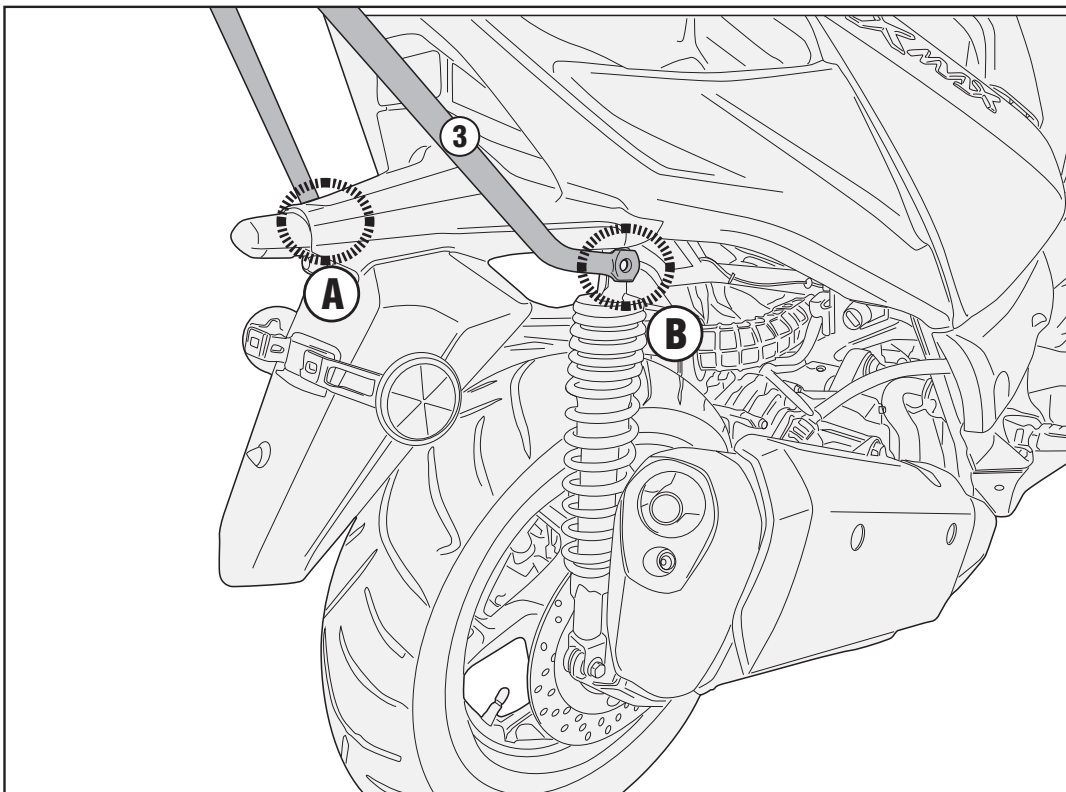
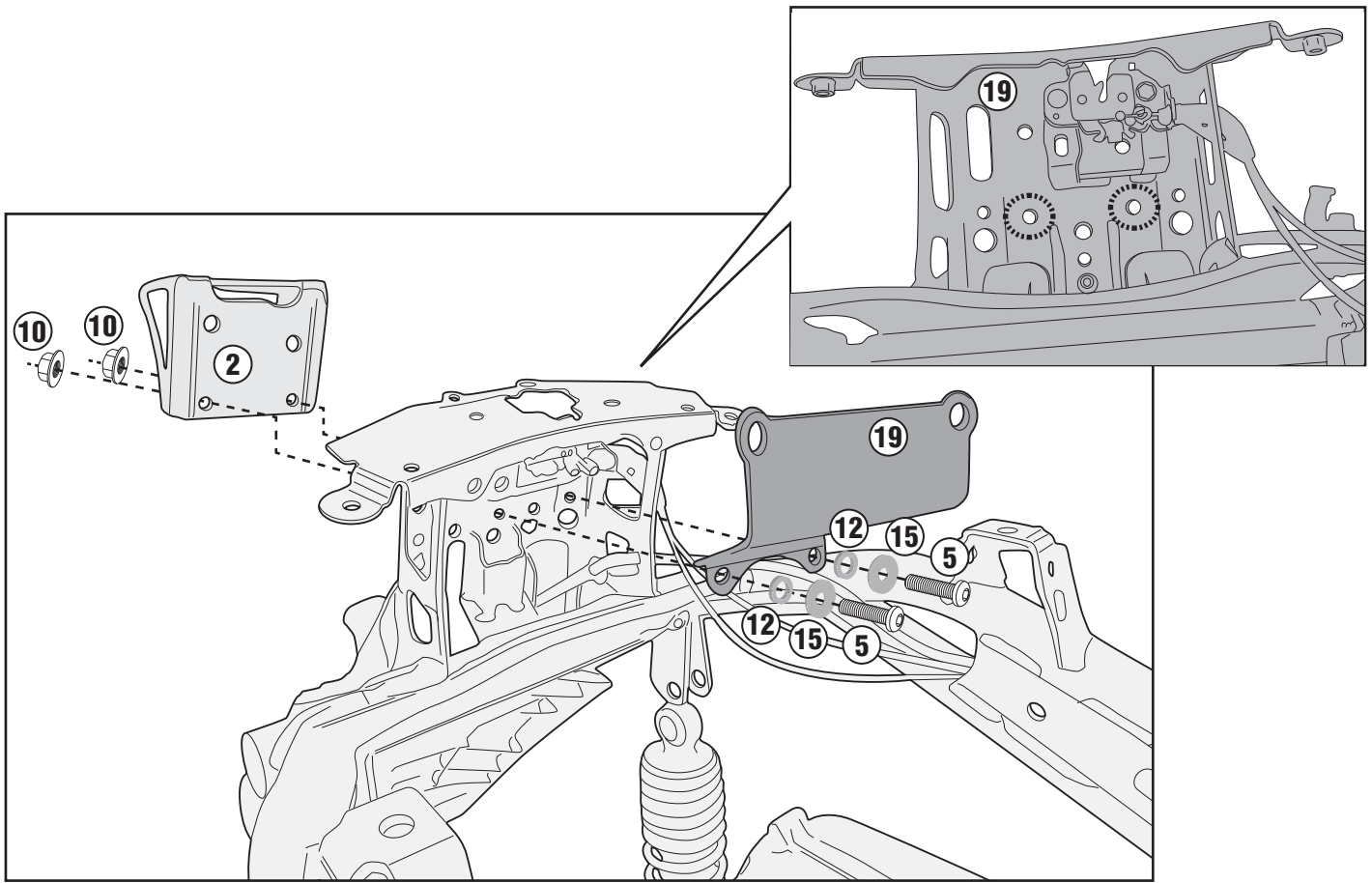

ISTRUZIONI DI MONTAGGIO - MOUNTING INSTRUCTIONS
INSTRUCTIONS DE MONTAGE - BAUANLEITUNG
INSTRUCCIONES DE MONTAJE - INSTRUÇÕES DE MONTAGEM

SR2138 - KR2138

PORTAPACCO SPECIFICO - SPECIFIC HOLDER - PORTE-PAQUET SPÉCIFIQUE - SPEZIFISCHER TRÄGER - PORTA-EQUIPAJE ESPECÍFICO - TRANSPORTADOR ESPECÍFICO

YAMAHA X-MAX 400 (2018)

LEFT SIDE

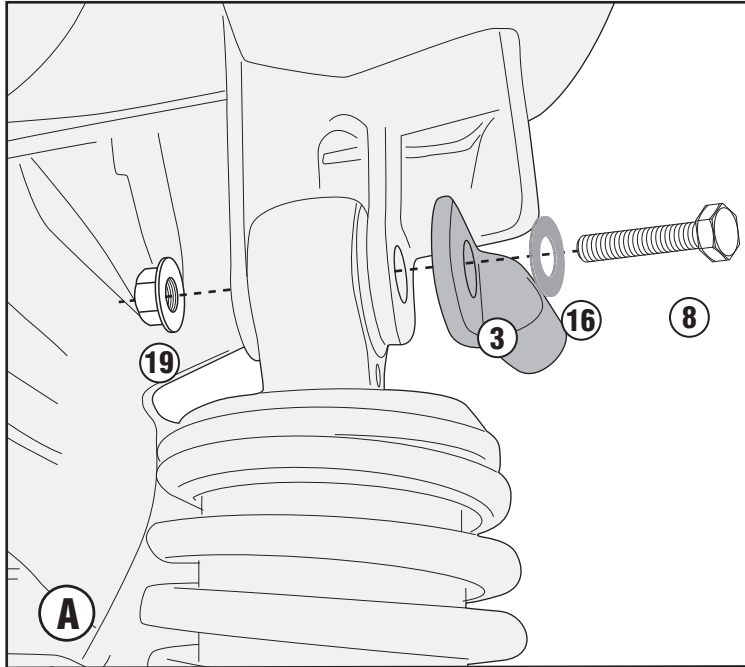

RIGHT SIDE

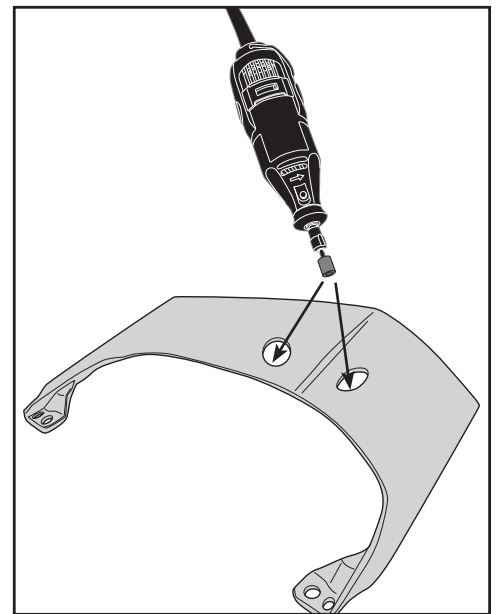
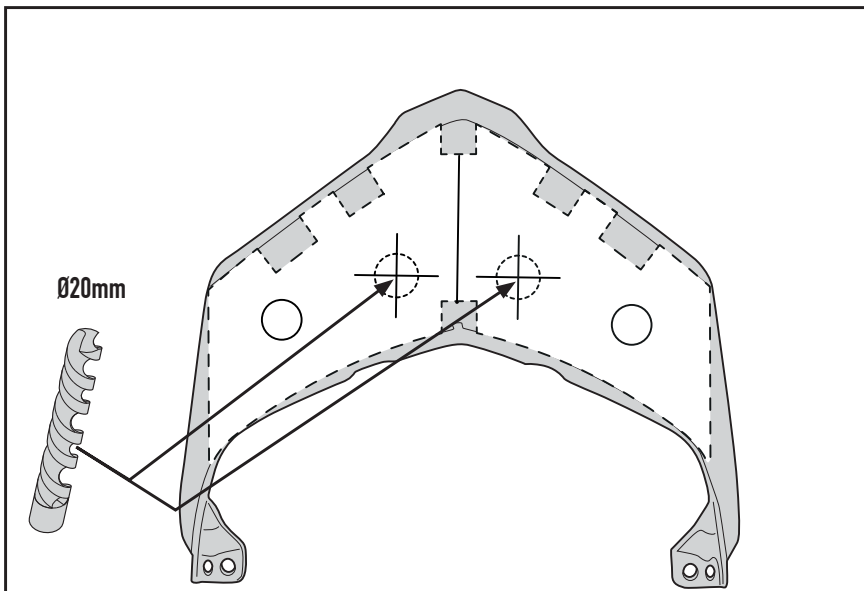
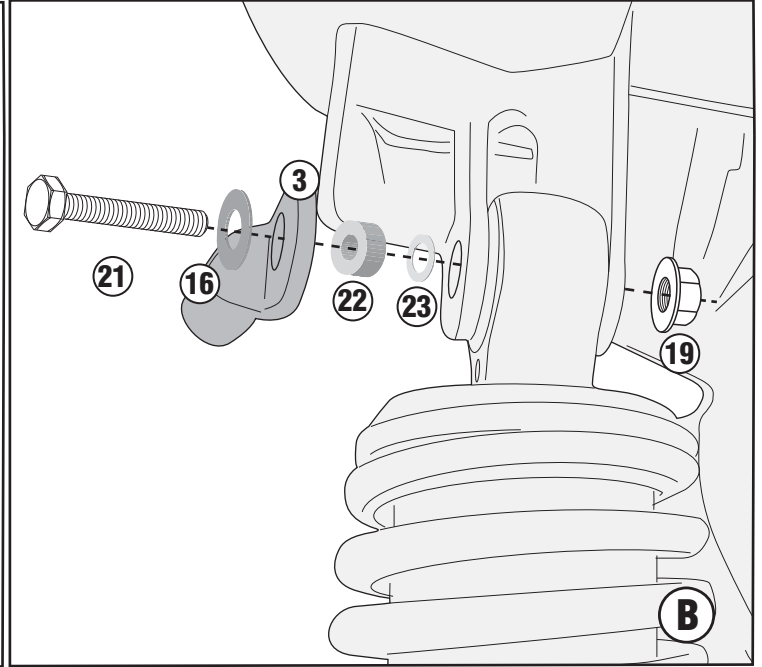

- A SOLARE QUANTO BASTA PER CREARE LA CORRETTA SEDE DEI DISTANZIALI N. 13

- USING THE TEMPLATE, MARK THE TWO HOLES TO BE DRILLED. USING A 20MM DRILL BIT, DRILL THE HOLES AND ENLARGE ENOUGH FOR THE SPACERS No.13

- BENUTZEN SIE DIE VORLAGE, UM DIE LÖCHER FÜR DIE BOHRUNG ZU MARKIEREN. NEHMEN SIE EIN 20 MM-BIT, BOHREN SIE DIE LÖCHER, SO DASS DIESE WEIT GENUG FÜR DIE DISTANZHÜLSEN SIND Nr. 13

- À L'AIDE DU GABARIT, MARQUEZ LES DEUX TROUS À FORER. EN UTILISANT UN FORET DE 20 MM, PERCEZ LES TROUS DE SORTE QU'ILS SOIENT SUFFISAMMENT GRANDS POUR LES ENTRETOISES n° 13

- TALADRAR LO SUFICIENTE PARA CREAR ESPACIO PARA LOS DISTANCIADORES 13

- USANDO O GABARITO, MARQUE OS DOIS ORIFÍCIOS A SEREM PERFURADOS. USANDO UMA BROCA DE 20MM, PERFURE OS FURROS PARA QUE ELES SEJAM GRANDES O SUFICIENTE PARA OS ESPAÇADORES n° 13

SR2138 - KR2138

PORTAPACCO SPECIFICO - SPECIFIC HOLDER - PORTE-PAQUET SPÉCIFIQUE - SPEZIFISCHER TRÄGER - PORTA-EQUIPAJE ESPECÍFICO - TRANSPORTADOR ESPECÍFICO

YAMAHA X-MAX 400 (2018)

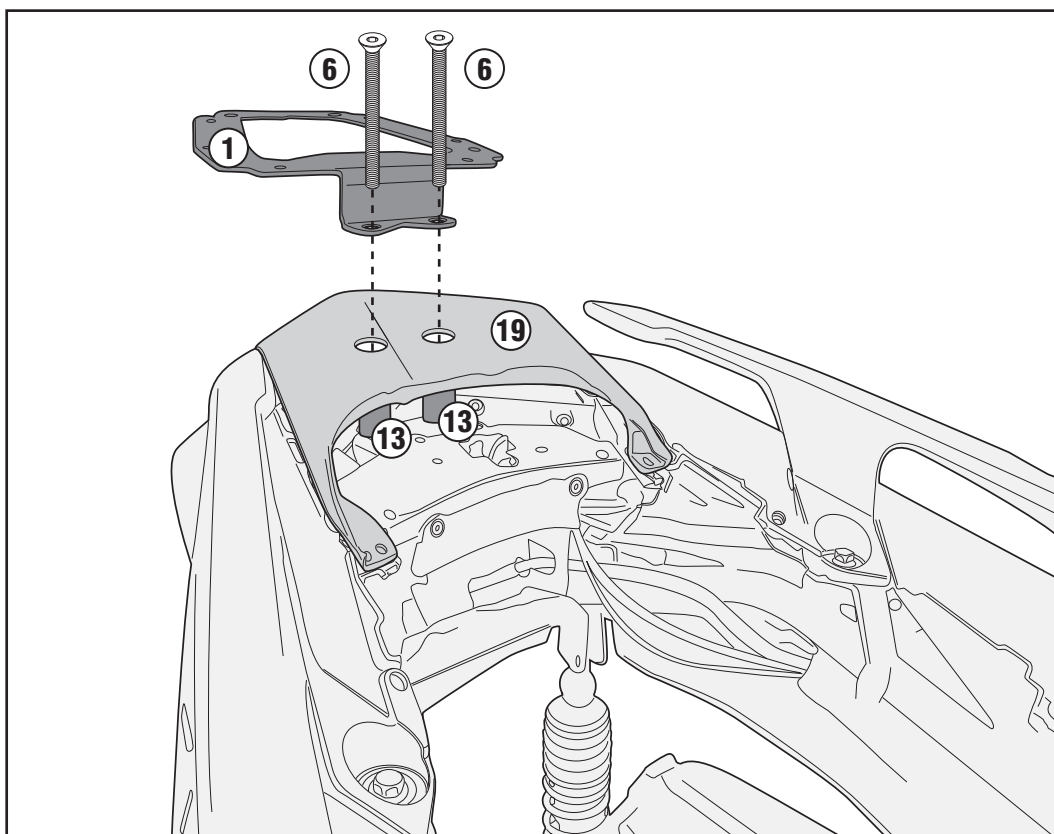
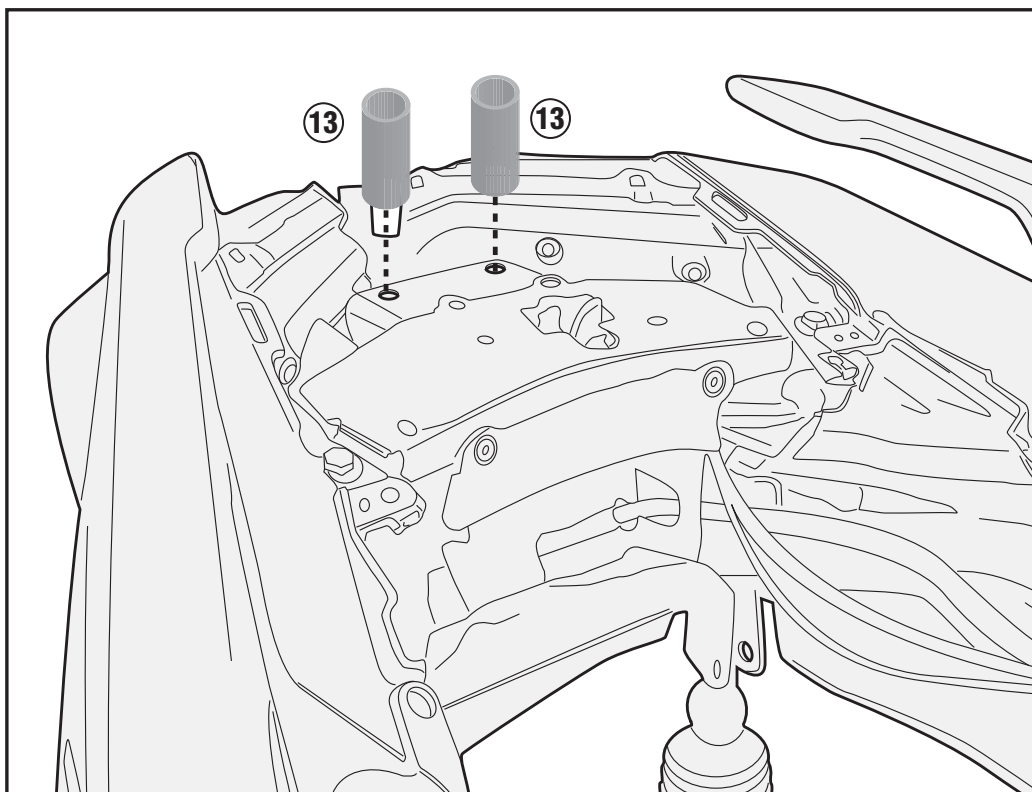

ISTRUZIONI DI MONTAGGIO - MOUNTING INSTRUCTIONS
INSTRUCTIONS DE MONTAGE - BAUANLEITUNG
INSTRUCCIONES DE MONTAJE - INSTRUÇÕES DE MONTAGEM

SR2138 - KR2138

PORTAPACCO SPECIFICO - SPECIFIC HOLDER - PORTE-PAQUET SPÉCIFIQUE - SPEZIFISCHER TRÄGER - PORTA-EQUIPAJE ESPECÍFICO - TRANSPORTADOR ESPECÍFICO

YAMAHA X-MAX 400 (2018)

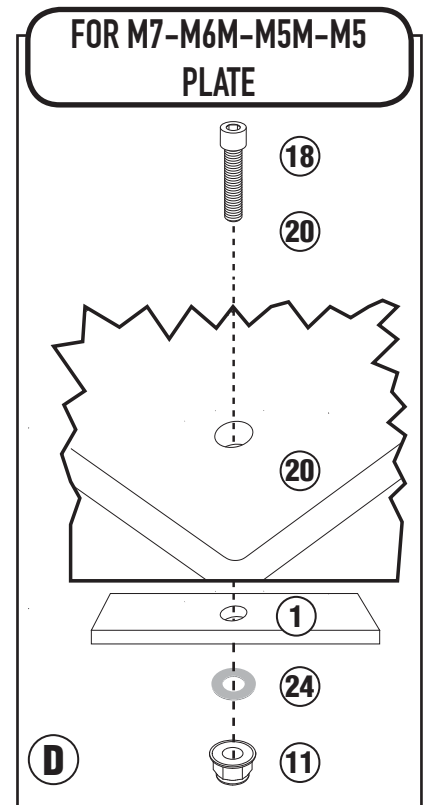
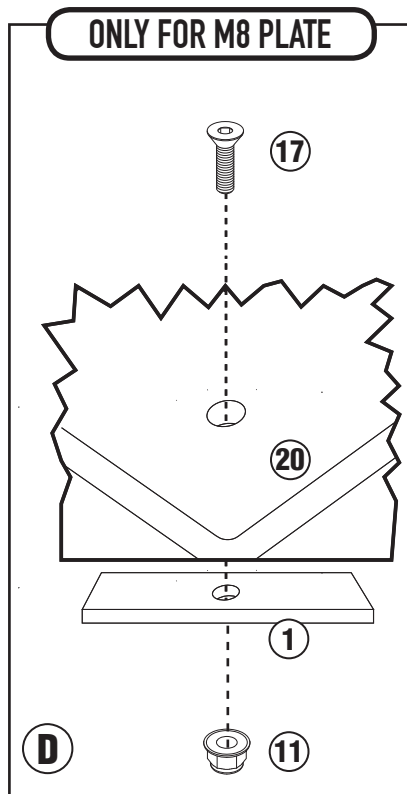
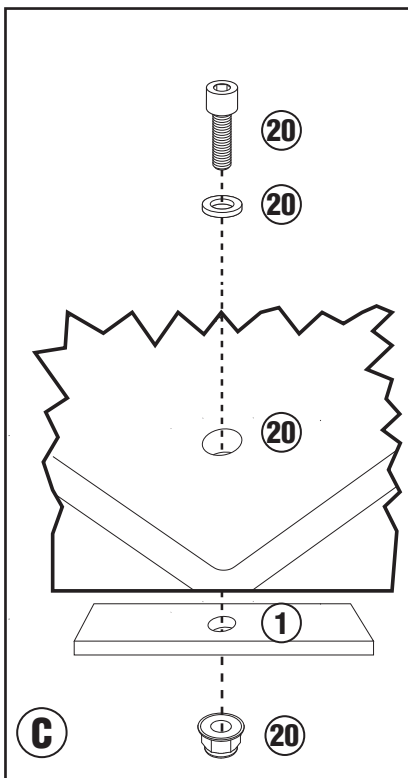
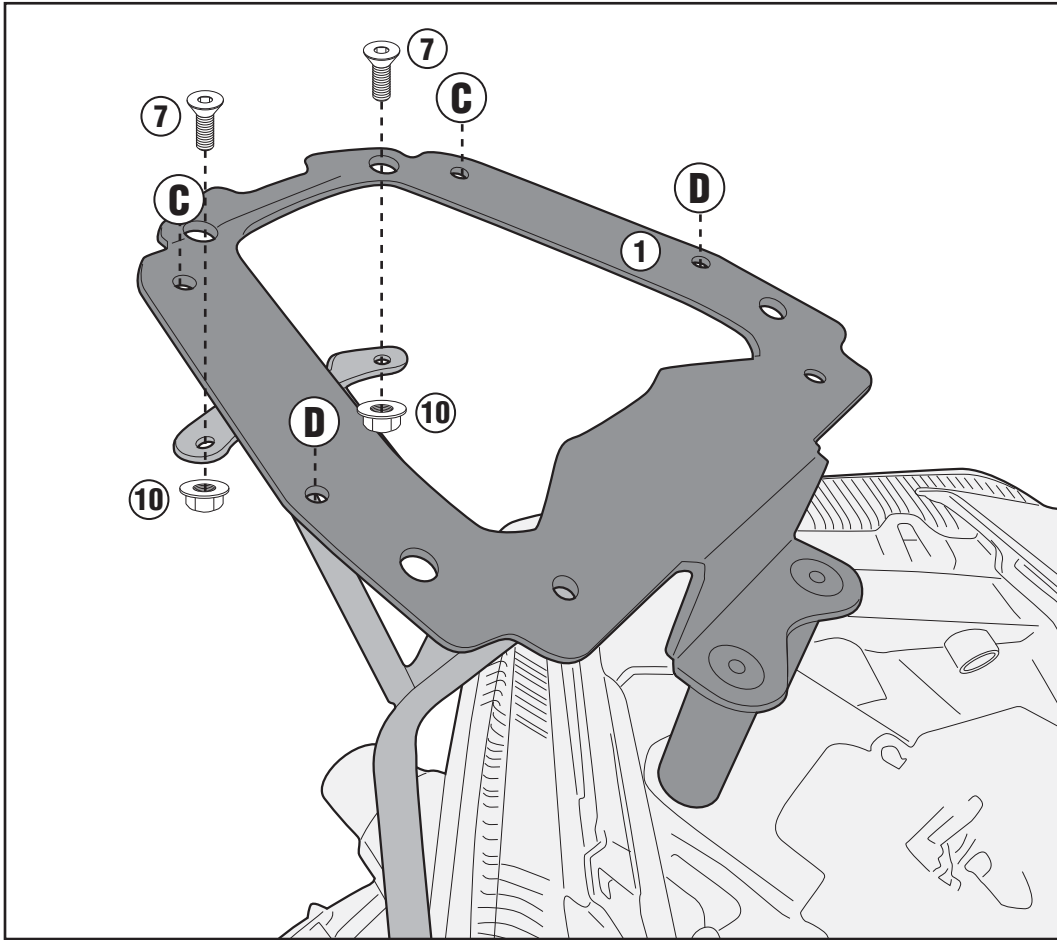

SR2138 - KR2138

PORTAPACCO SPECIFICO - SPECIFIC HOLDER - PORTE-PAQUET SPÉCIFIQUE - SPEZIFISCHER TRÄGER - PORTA-EQUIPAJE ESPECÍFICO - TRANSPORTADOR ESPECÍFICO

YAMAHA X-MAX 400 (2018)

. PRIMA DI FORARE VERIFICARE CHE LA DIMA CORRISPONDA ALLE MISURE INDICATE
. BEFORE DRILLING HOLES CHECK THAT MEASURES ON TEMPLATE CORRESPOND
. AVANT DE PERCER CONTROLER QUE LE GABARIT CORRESPOND AUX MESURES INDIQUEE
. BEVOR DER KOFFERDECKEL DURCHBOHRT WIRD, PRÜFEN SIE DAB DIE SCHABLONE DEN
GEGEBENEN ABMESSUNGEN ENTSPRICH
. ANTES DE HACER LOS AGUJEROS COMPROBAR LAS MEDIDAS DE LA PLANTILLA CORRE-
SPONIENTE

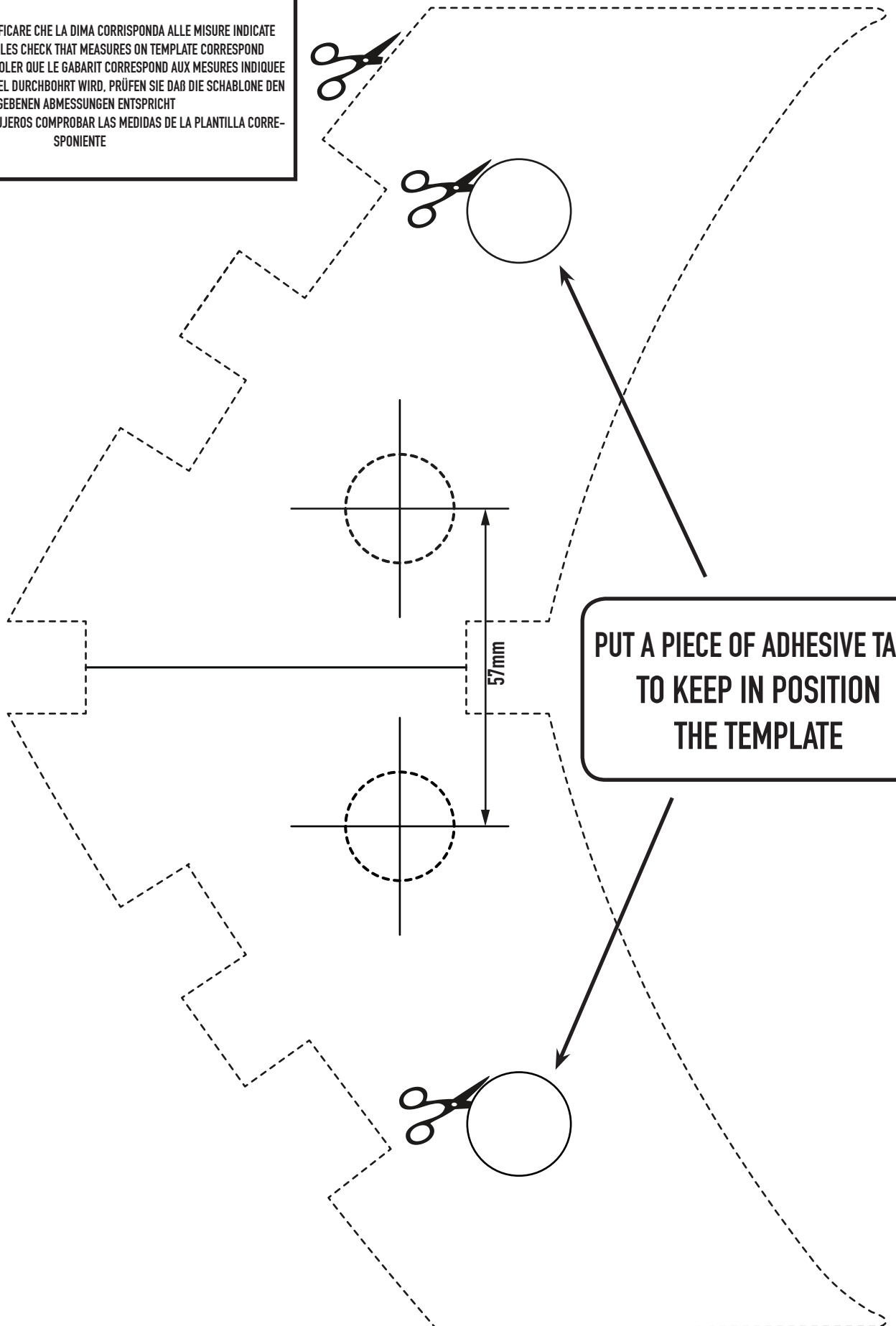

**PUT A PIECE OF ADHESIVE TAPE
TO KEEP IN POSITION
THE TEMPLATE**