

# TB3115 - KTB3115

SCHIENALINO SPECIFICO - SPECIAL BACKREST - DOSSERET SPÉCIFIQUE - SPEZIFISCHE BEIFAHNER-RÜCKENLEHNE  
RESPALDO ESPECÍFICO - APOIO ESPECÍFICO

## SUZUKI BURGMAN 400 (2017)

N°	Descrizione	Caratteristiche	Codice	Quantità
1	Schienalino - Backrest - Dossieret Beifahrer-rückenlehne - Respaldo - Apoio	-	TB3115	1
2	Piastrina con logo - Logo plate Plaque logo - Logo-Platte Placa de logotipo - Placa do logotipo	-	GL3649V	1
3	Vite - Screw Vis - Schraube Tornillo - Parafuso	TBEI M8x60	860TBEI	2
4	Vite - Screw Vis - Schraube Tornillo - Parafuso	TBEI M8x45	845TBEI	2
5	Distanziale - Spacer Entretoise - Distanzstueck Distanciador - Espaçador	Ø18x22 Foro 8,5 mm	C18L22F8,5T	2
6	Distanziale - Spacer Entretoise - Distanzstueck Distanciador - Espaçador	Ø18x37 Foro 8,5 mm	C18L37F8,5T	2
7	Rondella - Washer - Rondelle Scheibe - Arandela - Arruela	-	Z1060	4
8	Componenti originali - Original parts Parties originales - Original bauteile Componentes originales	-	-	-

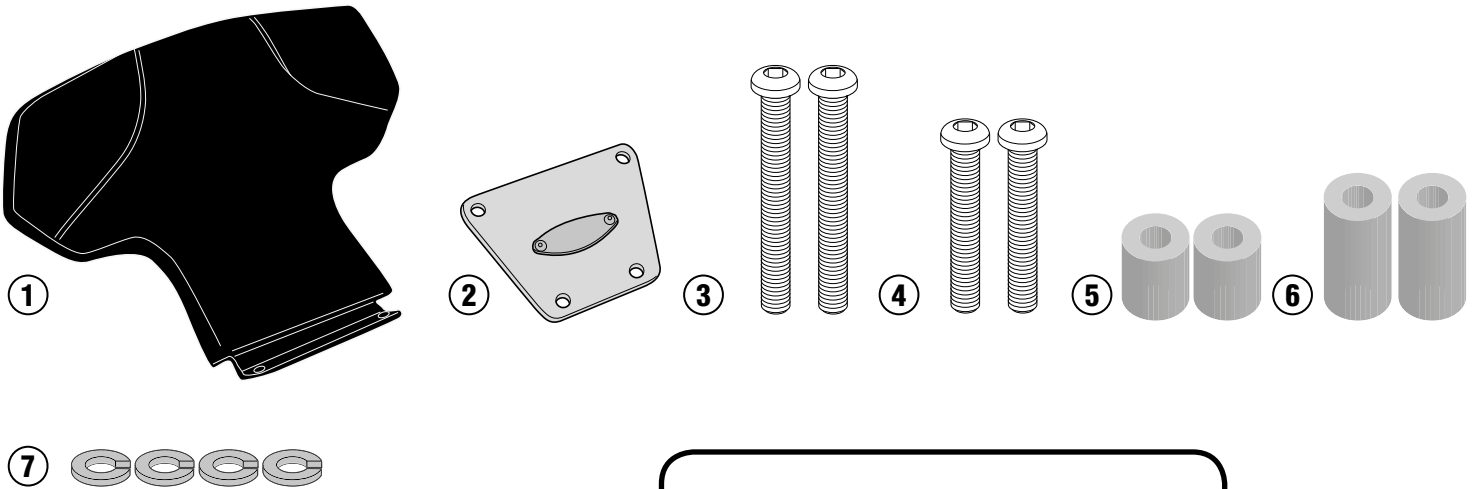

CAN BE MOUNT ONLY WITHOUT SR3115

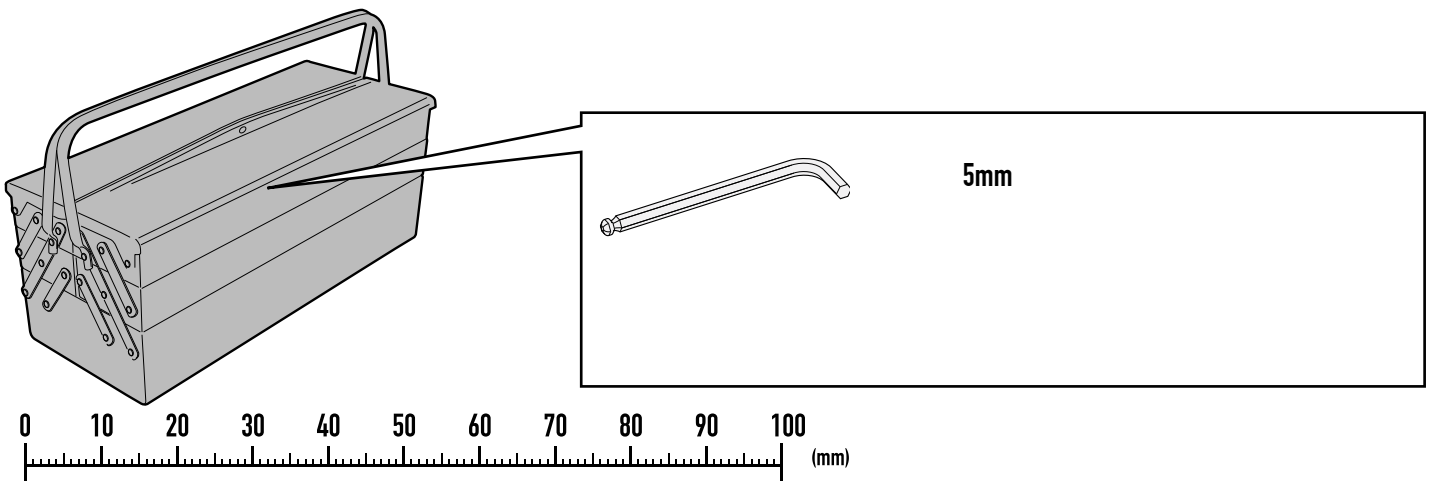

# TB3115 - KTB3115

SCHIENALINO SPECIFICO - SPECIAL BACKREST - DOSSERET SPÉCIFIQUE - SPEZIFISCHE BEIFAHREER-RÜCKENLEHNE

RESPALDO ESPECÍFICO - APOIO ESPECÍFICO

## SUZUKI BURGMAN 400 (2017)

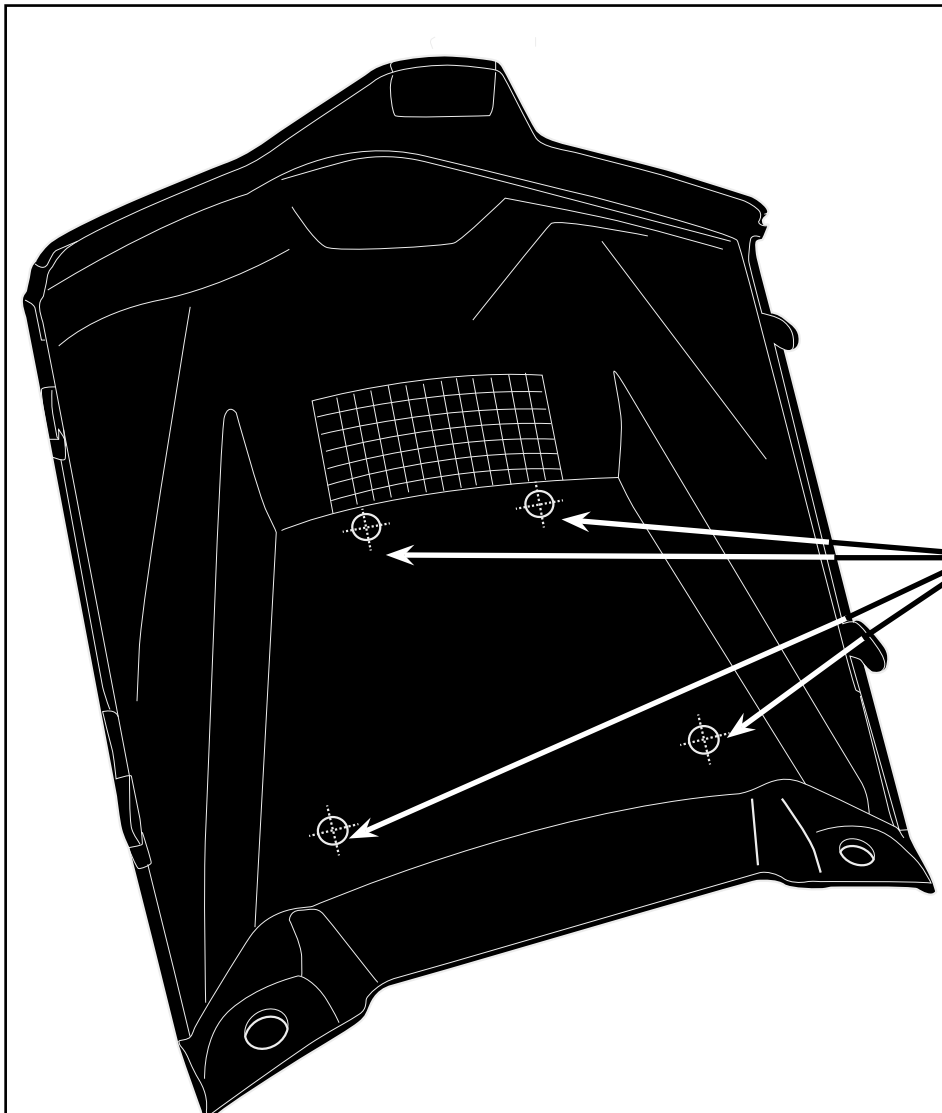
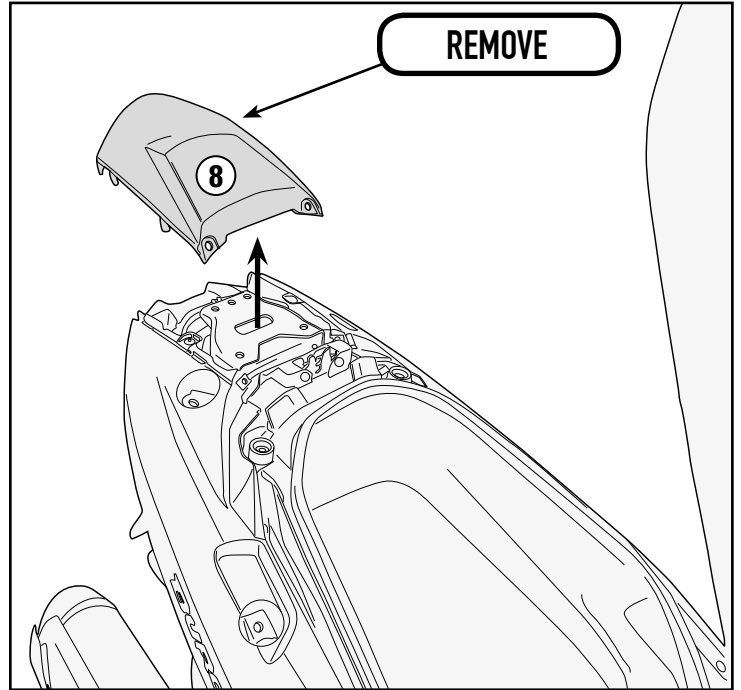
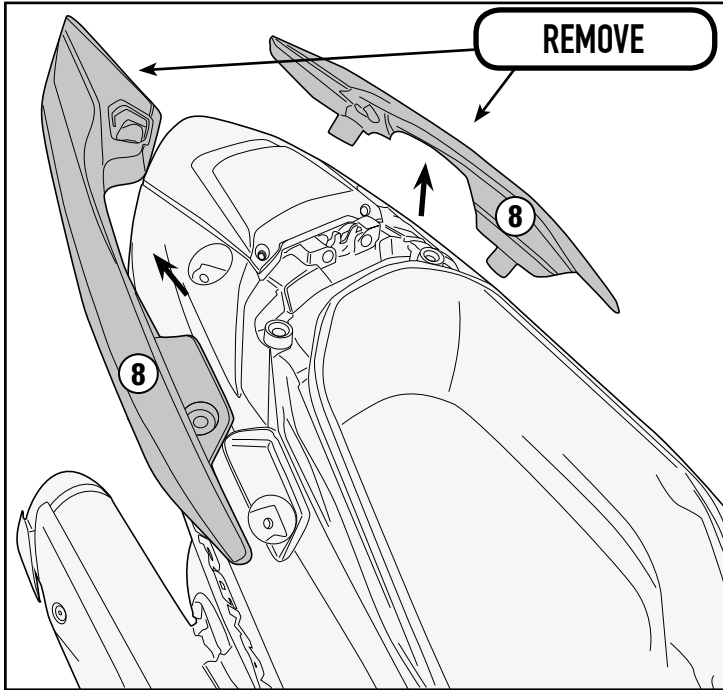

- FORARE NEI 4 PUNTI PREMARCATI
- DRILL HOLES IN THE FOUR POINTS PREMARKED
- PERCEZ DES TROUS DANS LES QUATRE POINTS PREMARQUEES
- LOCHER IN DIE VIER PUNKTE VORMARKIERTE
- PERFORAR LOS CUATRO PUNTOS PREVIAMENTE MARCADA
- BROCA OS QUATRO PONTOS PREVIAMENTE MARCADOS

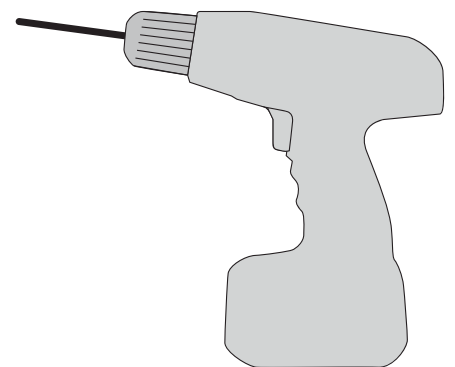

Ø18,5 mm

# TB3115 - KTB3115

SCHIENALINO SPECIFICO - SPECIAL BACKREST - DOSSERET SPÉCIFIQUE - SPEZIFISCHE BEIFAHREER-RÜCKENLEHNE  
RESPALDO ESPECÍFICO - APOIO ESPECÍFICO

## SUZUKI BURGMAN 400 (2017)

