

TN9052 - KN9052

PARAMOTORE SPECIFICO - SPECIFIC ENGINE GUARD - PARE-CARTER SPECIFIQUE SPEZIFISCHER STURZBÜGEL - DEFENSA DE MOTOR ESPECÍFICA - PARAMOTOR ESPECÍFICO

ROYAL ENFIELD CLASSIC 500 (2019)

N°	Descrizione-Description	Caratteristiche-Features	Codice-Code	Quantità-Quantity
1	Paramotore - Engine Guard Pare-carter - Sturzbuegel Defensa De Moto - Paramotor	-	TN9052DXV TN9052 SXV	2(Left; Right)
2	Piastrina di rinforzo - Strengthening plate Plaque de renfort - Verstärkungsplatte Pletina de refuerzo - Placa de reforço	-	GL4338	2(Left; Right)
3	Vite - Screw Vis - Schraube Tornillo - Parafuso	TCEX M12x130	12130TCEX	1
4	Vite - Screw Vis - Schraube Tornillo - Parafuso	TCEX M8x130	8130TCEX	2
5	Vite - Screw Vis - Schraube Tornillo - Parafuso	TECF M8x25	825TECF	3
6	Vite - Screw Vis - Schraube Tornillo - Parafuso	TECF M6x20	620TECF	2
7	Rondella - Washer Rondelle - Scheibe Arandela - Arruela	Foro Ø12mm	12RON	2
8	Rondella Inox - Stainless Steel Washer Rondelle Inox -Rostfreie Unterlegscheibe Aus Stahl Arandela Inox - Arruela Lisa De Aço Inox	Foro Ø8mm	8RONX	5
9	Rondella - Washer Rondelle - Scheibe Arandela - Arruela	Foro Ø8mm / Esterno Ø24mm Sp. 2mm	258RON	1
10	Rondella Inox - Stainless Steel Washer Rondelle Inox -Rostfreie Unterlegscheibe Aus Stahl Arandela Inox - Arruela Lisa De Aço Inox	Foro Ø8mm / Esterno Ø14mm Sp. 0,3mm	805RONX	2
11	Rondella Inox - Stainless Steel Washer Rondelle Inox -Rostfreie Unterlegscheibe Aus Stahl Arandela Inox - Arruela Lisa De Aço Inox	Foro Ø6mm / Esterno Ø18mm Sp. 1,5mm	618RONP	2
12	Dado - Bolt - Ecrou Mutter - Tuerca - Porca	Dado Autobloccante M12	12DADIAR	1
13	Dado - Bolt - Ecrou Mutter - Tuerca - Porca	Dado Autobloccante Flangiato Ribassato M8 (H9,6mm)	8DADIFN	1
14	Nipples	-	V906AN	1
15	O-RING	-	Z2161	2
16	Componenti Originali - Original Parts Parties Originales - Original Bauteile Componentes Originales - Componentes Originais	-	-	-

TN9052 - KN9052

PARAMOTORE SPECIFICO - SPECIFIC ENGINE GUARD - PARE-CARTER SPECIFIQUE SPEZIFISCHER STURZBÜGEL - DEFENSA DE MOTOR ESPECÍFICA - PARAMOTOR ESPECÍFICO

ROYAL ENFIELD CLASSIC 500 (2019)

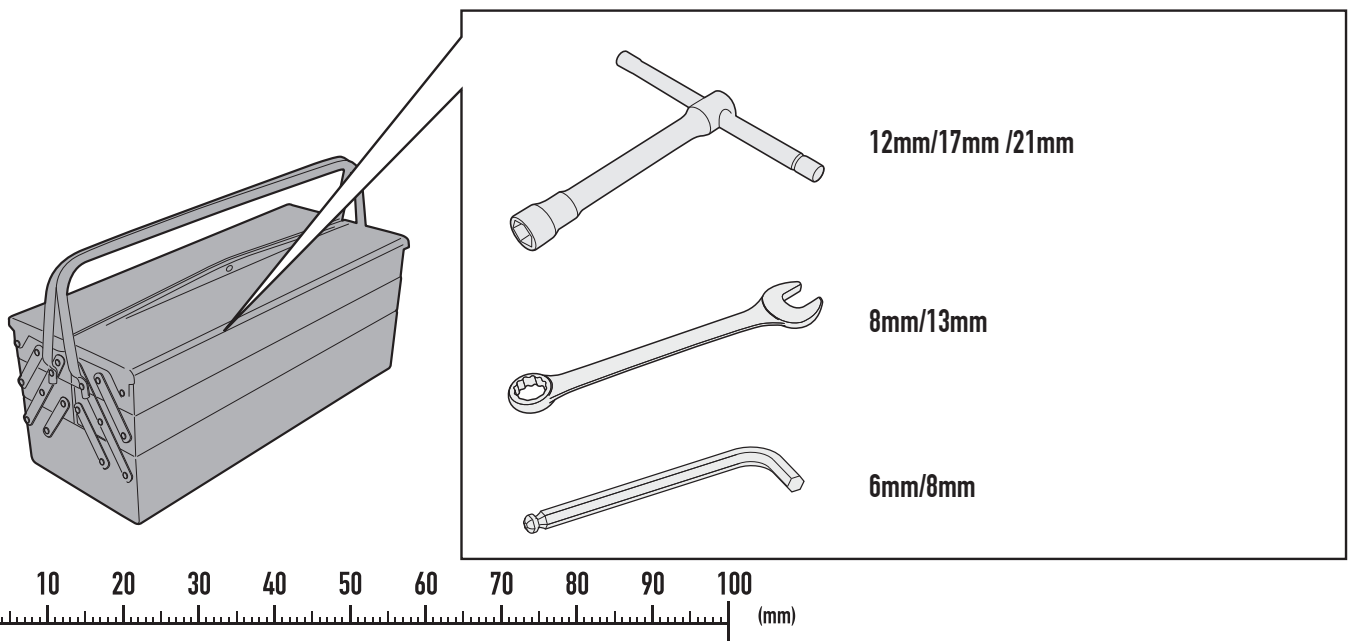
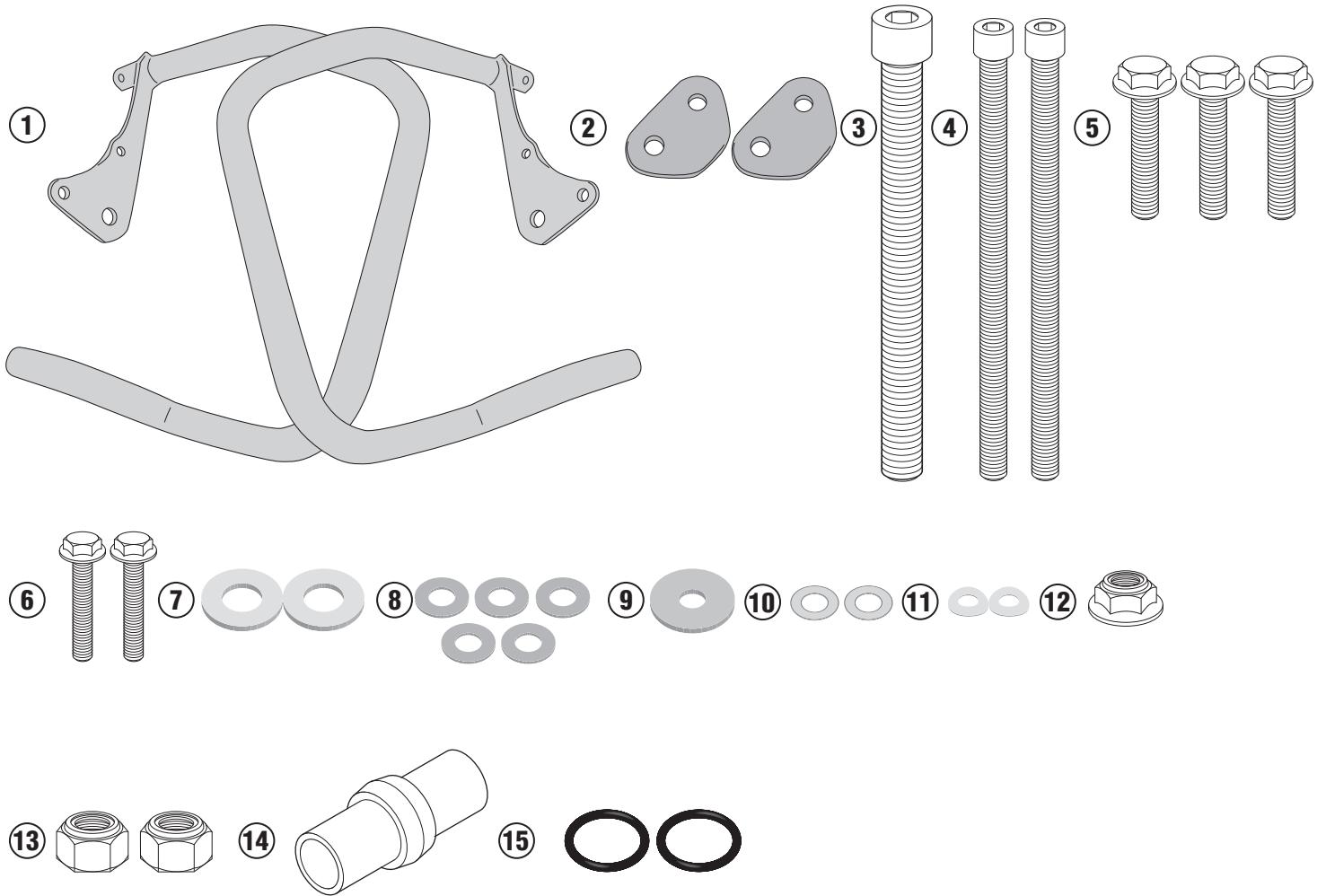

TN9052 - KN9052

PARAMOTORE SPECIFICO - SPECIFIC ENGINE GUARD - PARE-CARTER SPECIFIQUE SPEZIFISCHER STURZBÜGEL - DEFENSA DE MOTOR ESPECÍFICA - PARAMOTOR ESPECÍFICO

ROYAL ENFIELD CLASSIC 500 (2019)

LATO SINISTRO -LEFT SIDE - CÔTÉ GAUCHE
LINKE SEITE - LADO IZQUIERDO - LADO ESQUERDO

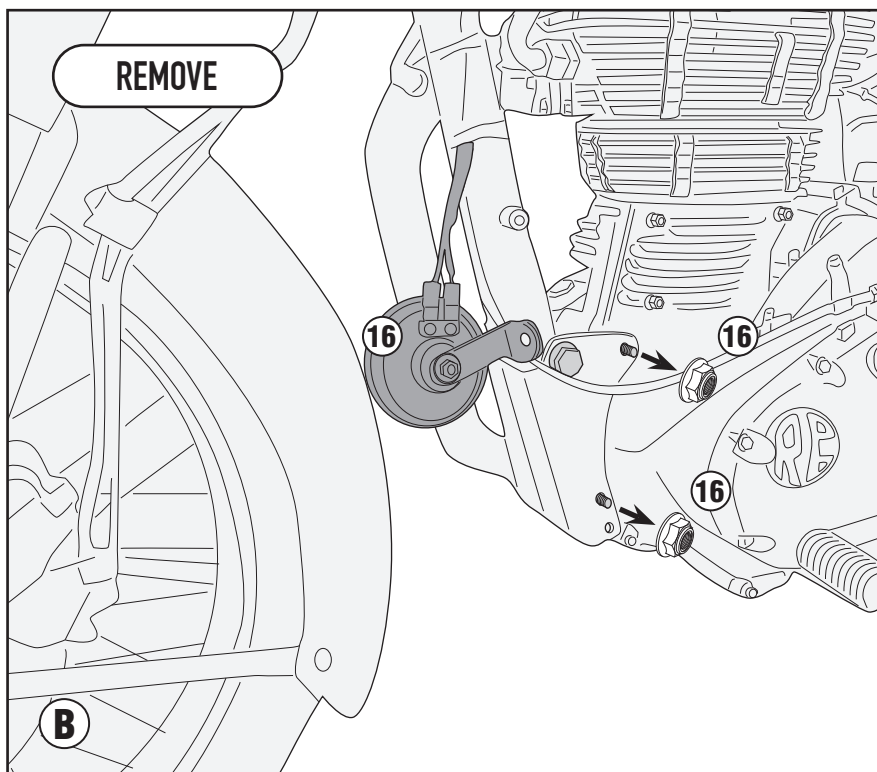
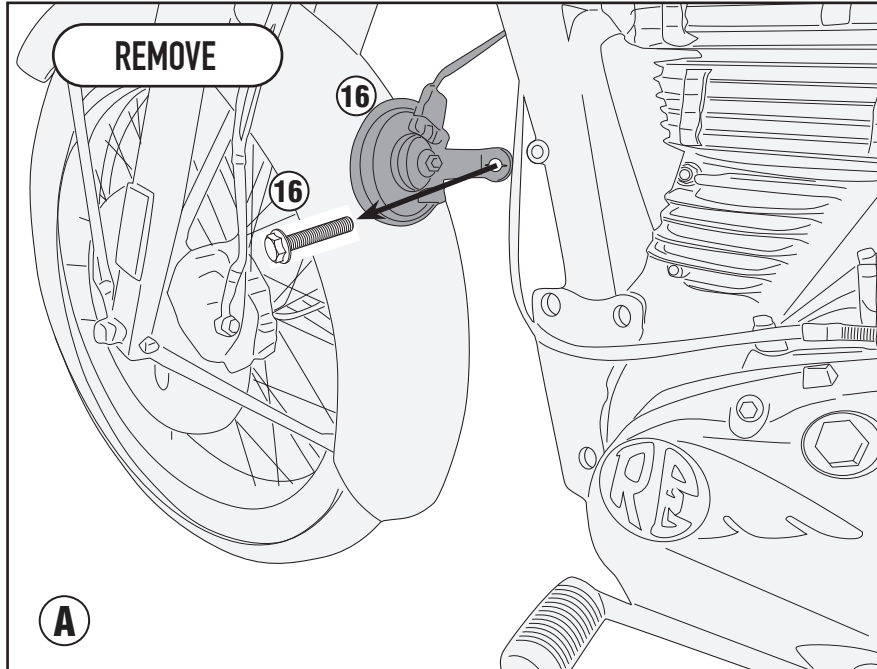

TN9052 - KN9052

PARAMOTORE SPECIFICO - SPECIFIC ENGINE GUARD - PARE-CARTER SPECIFIQUE SPEZIFISCHER STURZBÜGEL - DEFENSA DE MOTOR ESPECÍFICA - PARAMOTOR ESPECÍFICO

ROYAL ENFIELD CLASSIC 500 (2019)

LATO SINISTRO - LEFT SIDE - CÔTÉ GAUCHE
LINKE SEITE - LADO IZQUIERDO - LADO ESQUERDO

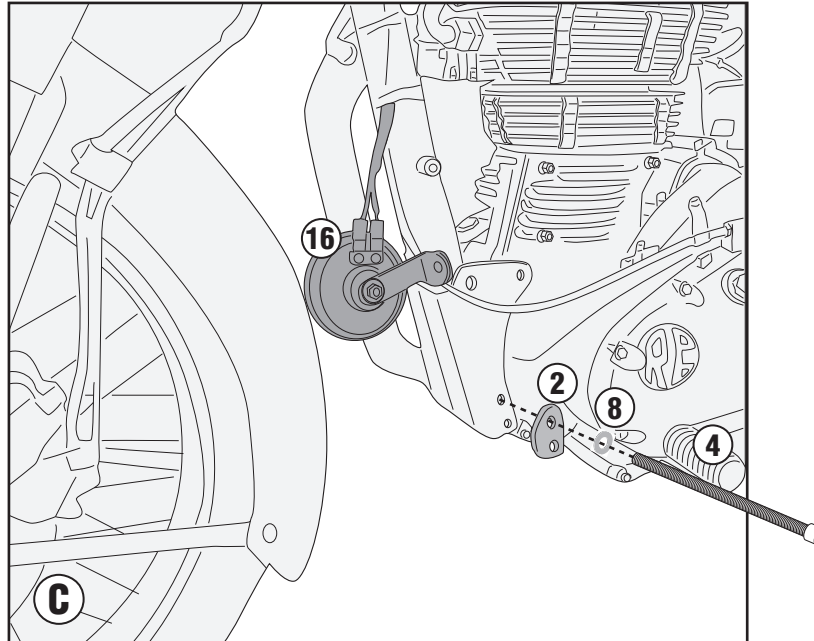

LATO DESTRO - RIGHT SIDE - CÔTÉ DROIT
RECHTE SEITE - LADO DERECHO - LADO DIREITO

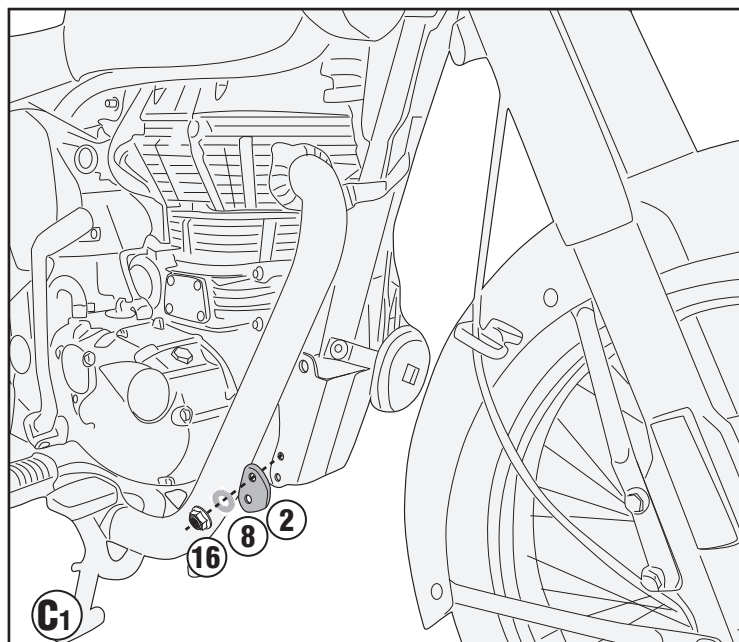

TN9052 - KN9052

PARAMOTORE SPECIFICO - SPECIFIC ENGINE GUARD - PARE-CARTER SPECIFIQUE SPEZIFISCHER STURZBÜGEL - DEFENSA DE MOTOR ESPECÍFICA - PARAMOTOR ESPECÍFICO

ROYAL ENFIELD CLASSIC 500 (2019)

LATO SINISTRO - LEFT SIDE - CÔTÉ GAUCHE
LINKE SEITE - LADO IZQUIERDO - LADO ESQUERDO

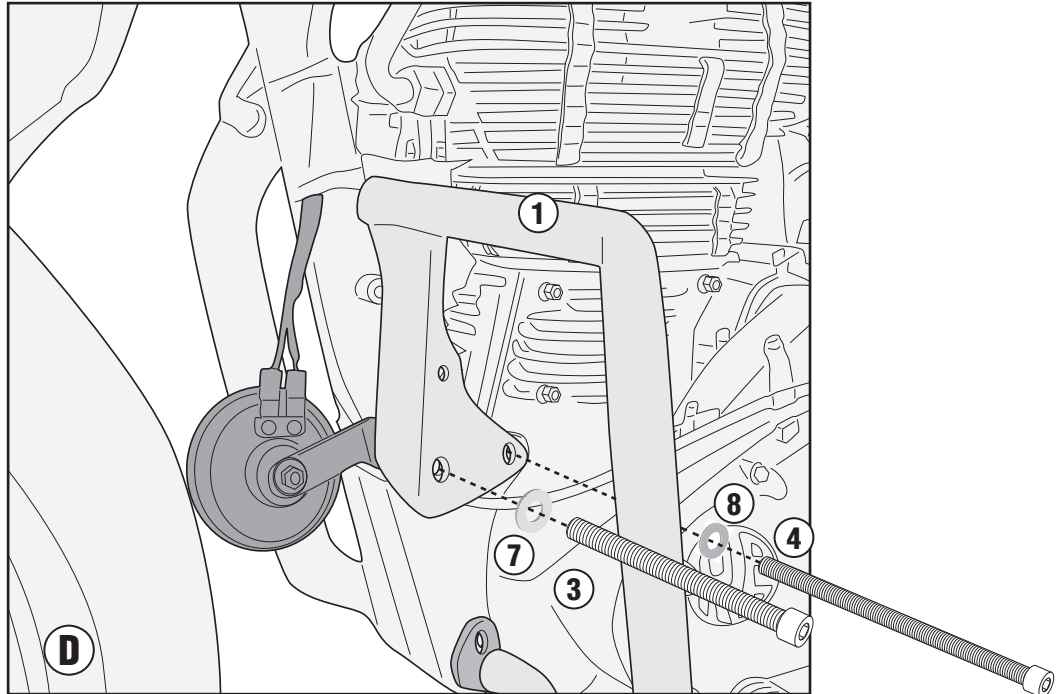

LATO DESTRO - RIGHT SIDE - CÔTÉ DROIT
RECHTE SEITE - LADO DERECHO - LADO DIREITO

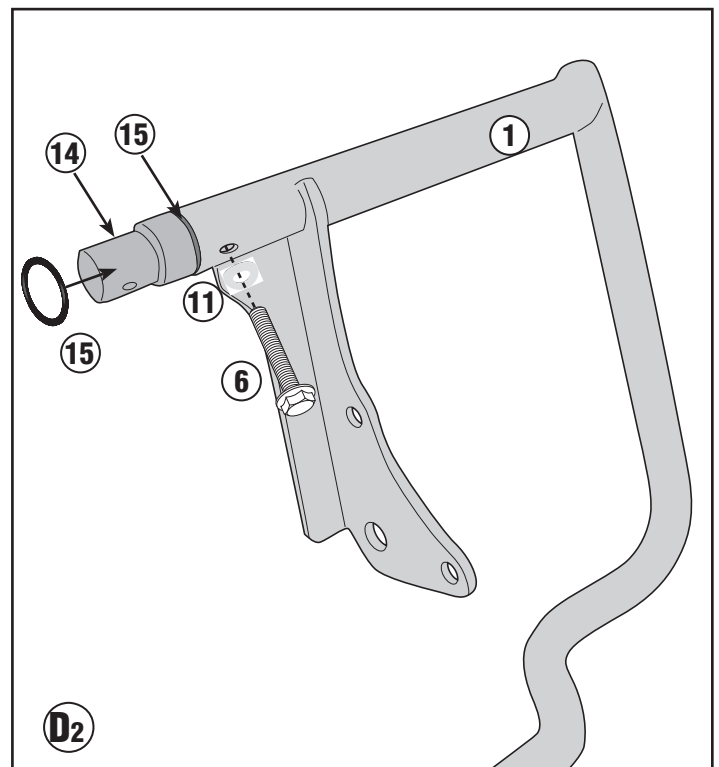
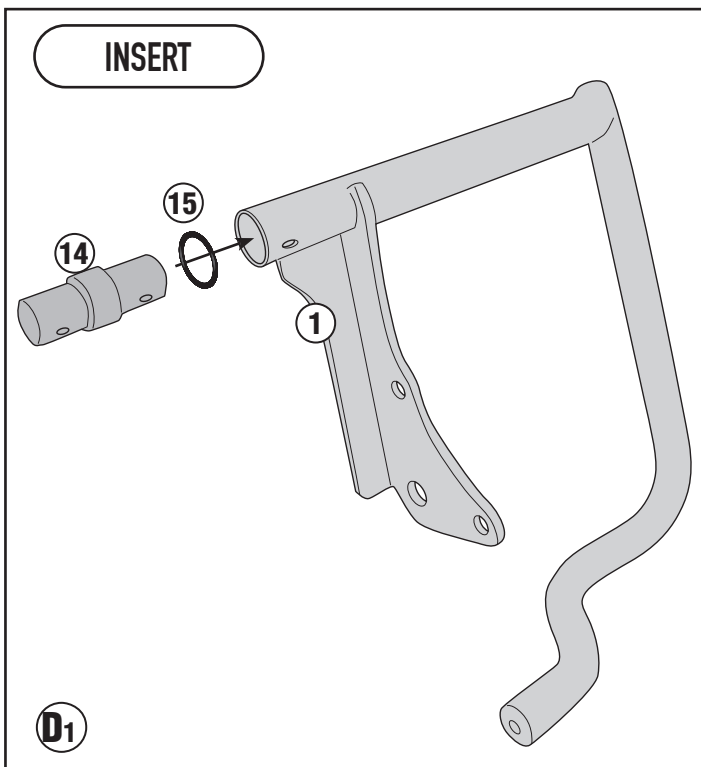

TN9052 - KN9052

PARAMOTORE SPECIFICO - SPECIFIC ENGINE GUARD - PARE-CARTER SPECIFIQUE SPEZIFISCHER STURZBÜGEL - DEFENSA DE MOTOR ESPECÍFICA - PARAMOTOR ESPECÍFICO

ROYAL ENFIELD CLASSIC 500 (2019)

LATO DESTRO - RIGHT SIDE - CÔTÉ DROIT
RECHTE SEITE - LADO DERECHO - LADO DIREITO

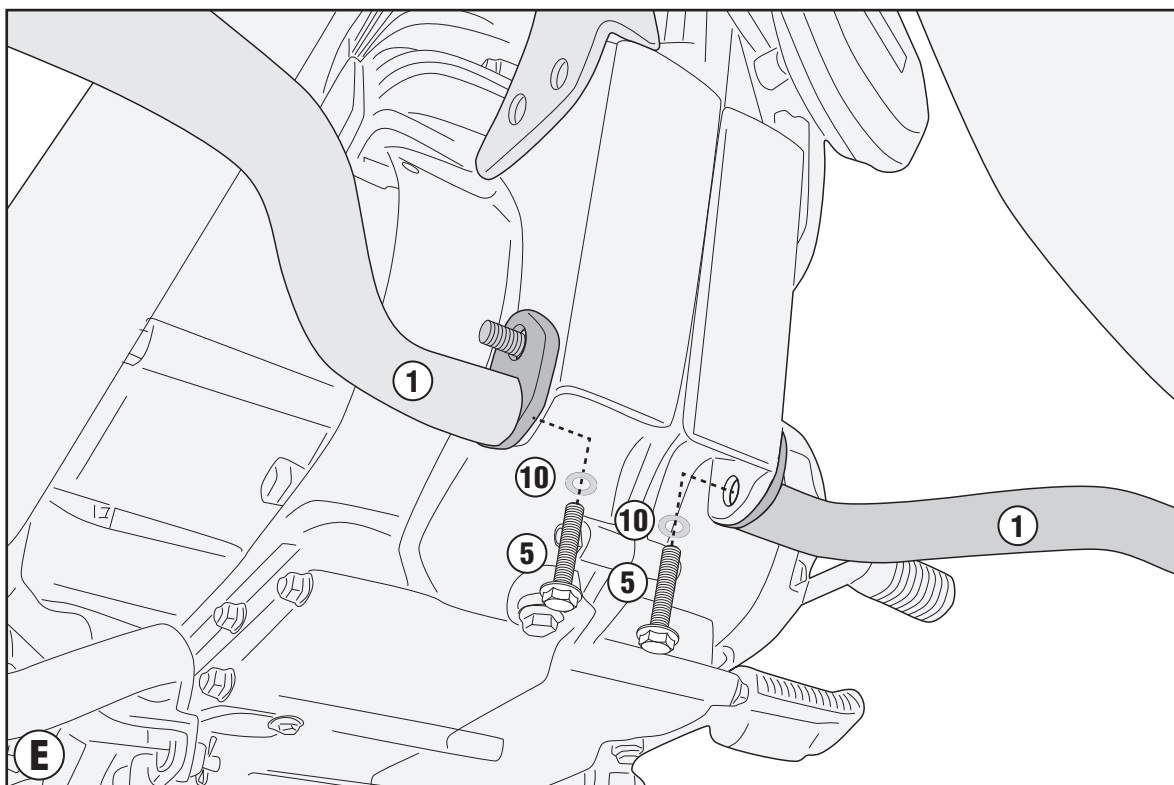
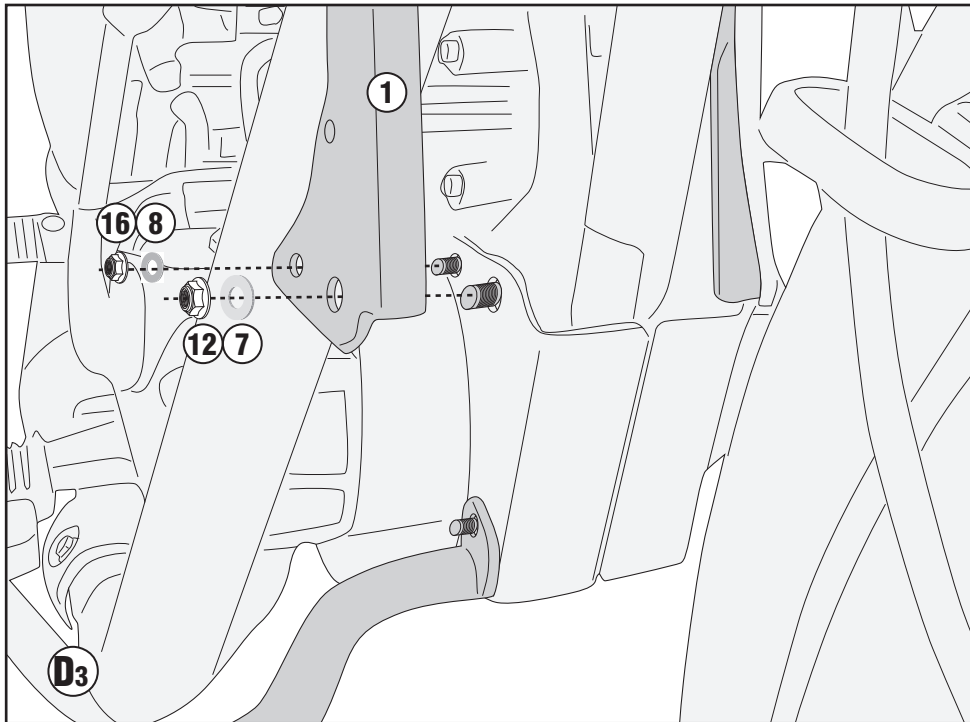

TN9052 - KN9052

PARAMOTORE SPECIFICO - SPECIFIC ENGINE GUARD - PARE-CARTER SPECIFIQUE SPEZIFISCHER STURZBÜGEL - DEFENSA DE MOTOR ESPECÍFICA - PARAMOTOR ESPECÍFICO

ROYAL ENFIELD CLASSIC 500 (2019)

