

PORTAVALIGIA SPECIFICO - SPECIFIC CASE HOLDER
 PORTE-VALISE SPECIFIQUE - SPEZIFISCHER KOFFER-TRÄGER
 PORTA-EQUIPAJE ESPECIFICO

BMW R1200GS 04/08

ISTRUZIONI DI MONTAGGIO - MOUNTING INSTRUCTIONS
 INSTRUCTIONS DE MONTAGE - BAUANLEITUNG - INSTRUCCIONES DE MONTAJE

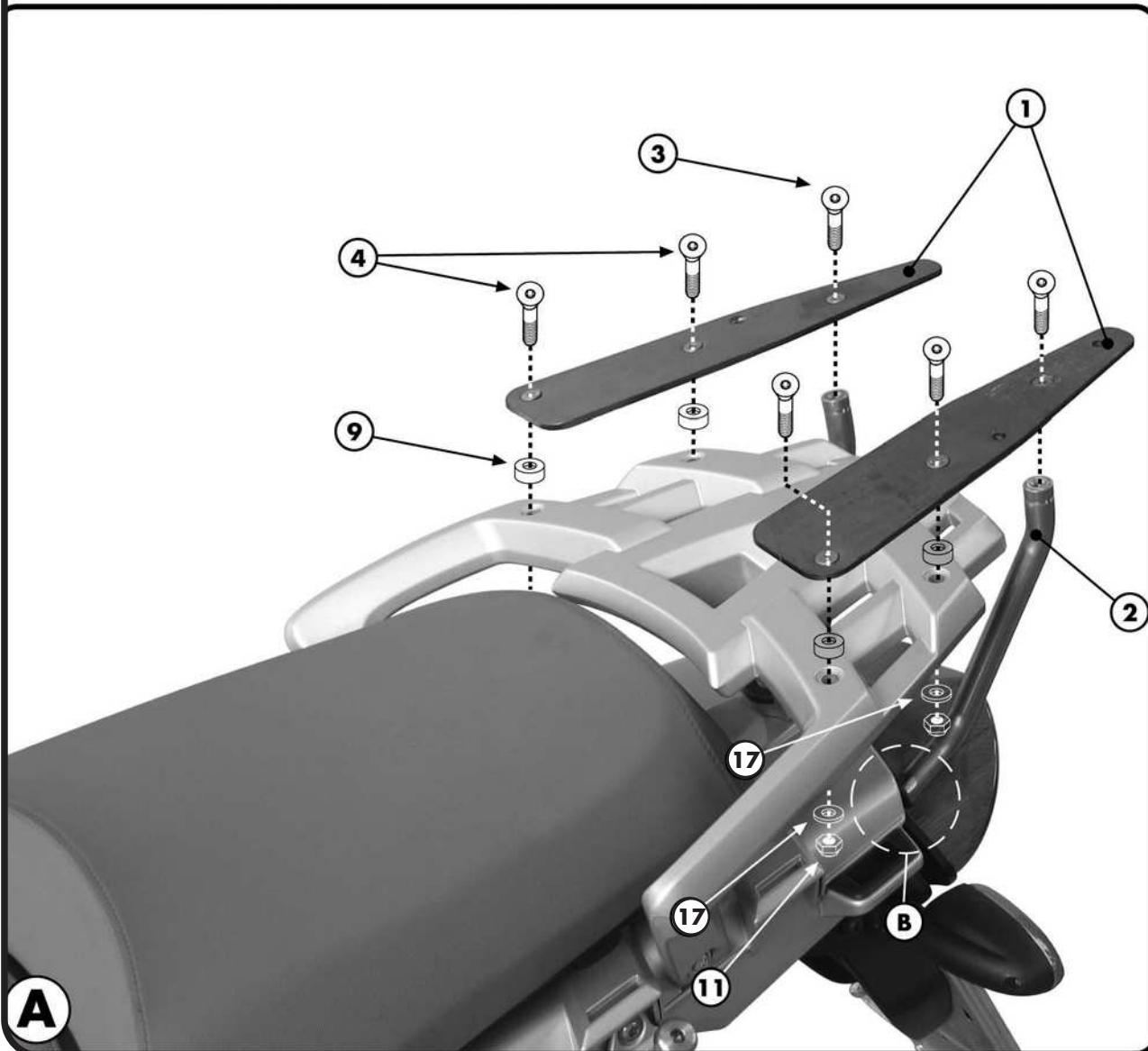
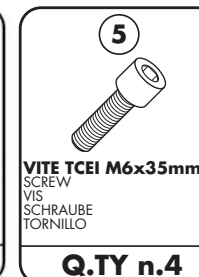

ATTENZIONE: PESO MASSIMO SOPPORTABILE 6Kg.

WARNING: MAX. LOADING 6Kg.(13lbs)

ATTENTION: CHARGE MAXIMALE 6Kg.

ACHTUNG: MAXIMALE BELASTUNG 6Kg.

¡ATENCIÓN!: CARGA MÁXIMA AUTORIZADA 6Kg.

PORTAVALIGIA SPECIFICO - SPECIFIC CASE HOLDER
 PORTE-VALISE SPECIFIQUE - SPEZIFISCHER KOFFER-TRAGER
 PORTA-EQUIPAJE ESPECIFICO

BMW R1200GS 04/08

ISTRUZIONI DI MONTAGGIO - MOUNTING INSTRUCTIONS
 INSTRUCTIONS DE MONTAGE - BAUANLEITUNG - INSTRUCCIONES DE MONTAJE

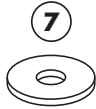

7
RONDELLA Ø6x20mm
 WASHER
 RONDELLE
 SCHEIBE
 ARANDELA

Q.TY n.4



8
RONDELLA Ø6
 WASHER Ø6
 RONDELLE Ø6
 SCHEIBE Ø6
 ARANDELA Ø6

Q.TY n.4



9
DISTANZIALE 12,5x5mm
foro Ø8mm
 SPACER
 ENTRETOISE
 DISTANZSTUECK
 DISTANCIADOR

Q.TY n.4



10
DADO A.B. M6
 BOLT M6
 ECROU M6
 MUTTER M6
 TUERCA M6

Q.TY n.4



11
DADO A.B. RIB. M6
 BOLT M6
 ECROU M6
 MUTTER M6
 TUERCA M6

Q.TY n.4



12
PIASTRA MONKEY
 PLATE
 PLATINE
 PLATTE
 PLETINA

Q.TY n.1

13



COPRIFORO
 BOLT CAP
 CACHE TROU
 STOPLOCK
 TAPA AGUJERO

Q.TY n.6

14

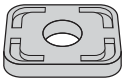

GOMMINO
Z1822
 RUBBER
 CAOUTCHOUC
 GUMMI
 GOMA

Q.TY n.4

15



RONDELLA IN GOMMA
Z1823
 RUBBER WASHER
 RONDELLE EN GOMME
 GUMMISCHEIBE
 ARANDELA DE GOMA

Q.TY n.4

16



DISTANZIALE Ø11x11mm
foro Ø6,5mm
V687
 SPACER
 ENTRETOISE
 DISTANZSTUECK
 DISTANCIADOR

Q.TY n. 4

17



RONDELLA Ø6x18mm
 WASHER Ø6x18mm
 RONDELLE Ø6x18mm
 SCHEIBE Ø6x18mm
 ARANDELA Ø6x18mm

Q.TY n.4

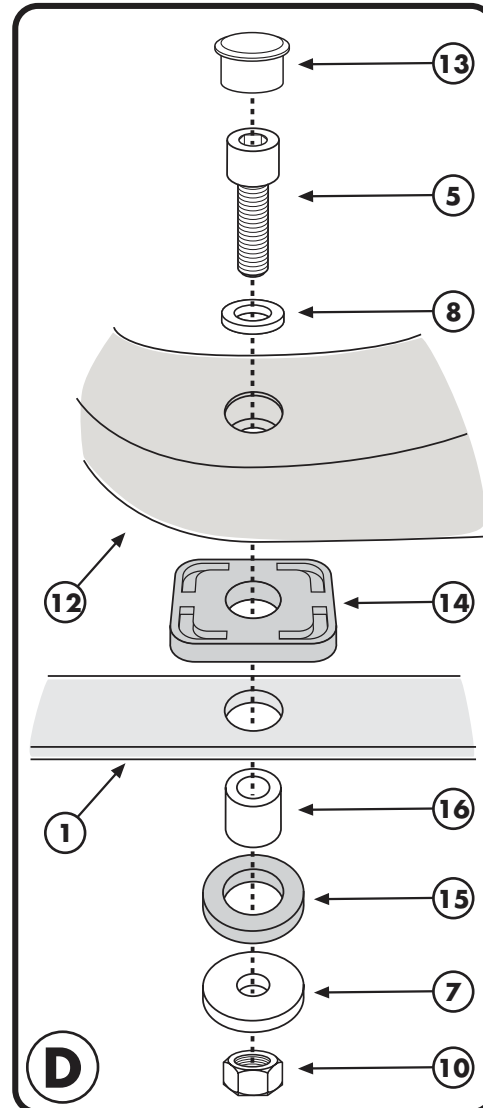
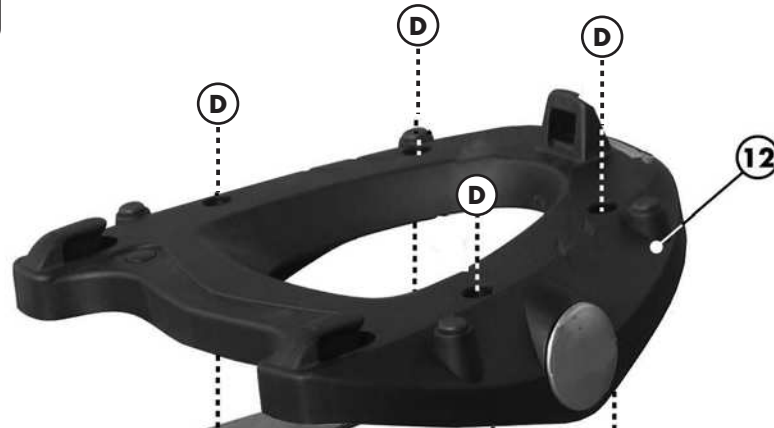

C

PORTAVALIGIA SPECIFICO - SPECIFIC CASE HOLDER
 PORTE-VALISE SPECIFIQUE - SPEZIFISCHER KOFFER-TRÄGER
 PORTA-EQUIPAJE ESPECIFICO

BMW R1200GS 04/08

ISTRUZIONI DI MONTAGGIO - MOUNTING INSTRUCTIONS
 INSTRUCTIONS DE MONTAGE - BAUANLEITUNG - INSTRUCCIONES DE MONTAJE

I ISTRUZIONI DI MONTAGGIO

1. POSIZIONARE I SUPPORTI N°1 E N°2 COME INDICATO IN FOTO A; FAR RIFERIMENTO ALLA FOTO B PER FISSARE I SUPPORTI N°2 CON LE VITI N°6, TOGLIENDO PRIMA LE VITI ORIGINALI CHE OCCUPANO LA PARTE INTERESSATA NEL MONTAGGIO DEL PORTAVALIGIA SPECIFICO;
2. CONTROLLARE CHE TUTTE LE VITI SIANO SERRATE BENE;
3. MONTARE LA PIASTRA COME INDICATO IN FOTO C;
4. ULTIMARE IL MONTAGGIO CONTROLLANDO CHE TUTTE LE VITI SIANO SERRATE BENE.

GB MOUNTING INSTRUCTIONS

1. PLACE THE SUPPORTS N° 1 AND 2 AS SHOWN IN PICTURE A; REMOVE THE ORIGINAL SCREWS AND WITH REFERENCE TO PICTURE B FIX THE SUPPORTS N° 2 USING THE SCREWS N° 6;
2. CHECK THAT ALL THE SCREWS OF THE SUPPORTS HAVE BEEN TIGHTENED;
3. MOUNT THE PLATE AS SHOWN IN PICTURE C;
4. LASTLY CHECK THAT ALL SCREWS ARE TIGHT.

F INSTRUCTIONS DE MONTAGE

1. POSITIONNER LE SUPPORTS N°1 ET N°2 COMME INDIQUE SUR LA PHOTO A; SE REFERER A LA PHOTO B POUR FIXER LES SUPPORTS N°2 AVEC LES VIS N°6, EN ENLEVANT, AVANT, LES VIS D'ORIGINE QUI OCCUPENT LA PARTIE CONCERNEE PAR LE MONTAGE DU SUPPORT DE TOP C ASE;
2. CONTROLER LE SERRAGE DES VIS;
3. MONTER LA PLATINE COMME INDIQUE SUR LA PHOTO C;
4. TERMINER LE MONTAGE EN CONTROLANT LE BON SERRAGE DE TOUTES LES VIS.

D BAUANLEITUNG

1. POSITIONIEREN SIE DIE HALTERUNGEN NR. 1 UND 2 WIE IM BILD A BESCHRIEBEN; ENTFERNEN SIE DIE ORIGINAL SCHRAUBEN WIE IM BILD B. BEFESTIGEN SIE DIE HALTERUNGEN NR. 2 MIT DEN SCHRAUBEN NR. 6;
2. ÜBERPRÜFEN SIE, DASS ALLE SCHRAUBEN FESTGEZOGEN WURDEN;
3. MONTIEREN SIE DIE PLATTE WIE IM BILD C BESCHRIEBEN;
4. ZULETZT ZIEHEN SIE ALLE SCHRAUBEN FEST.

ES

INSTRUCCIONES DE MONTAJE

1. QUITAR LOS TORNILLOS ORIGINALES INTERESADOS PARA EL MONTAJE DEL PORTAEQUIPAJE, MONTAR LOS SOPORTES N° 1 Y N° 2 COMO INDICA LA FOTO A, ANCLANDO LOS SOPORTES N° 2 POR LOS TORNILLOS N° 6;
2. APRETAR TODOS LOS TORNILLOS;
3. MONTAR LA PARRILLA COMO INDICA LA FOTO C;
4. TERMINAR APRETANDO TODOS LOS TORNILLOS