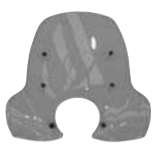

ATTACCHI SPECIFICI PER 106A - SPECIFIC FITTING KIT FOR 106A
 KIT DE MONTAGE SPECIFIQUE POUR 106A - SPEZIFISCHER MONTAGEKIT F R 106A
 ANCLAJE ESPEC FICO PARA 106A

PIAGGIO BEVERLY 500 2003

ISTRUZIONI DI MONTAGGIO - MOUNTING INSTRUCTIONS
 INSTRUCTIONS DE MONTAGE - BAUANLEITUNG - INSTRUCCIONES DE MONTAJE

1
106A

Q.TY n.1

2

SUPPORTO
 SUPPORT
 TRÄGER
 SOPORTES
Q.TY n.2(Dx-Sx)

3

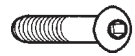
DADO SPECIALE V513
 BOLT
 ECROU
 MUTTER
 TUERCA
Q.TY n.2

4

VITE TBEI M6x25 nera
 SCREW M6x25 black
 VIS M6x25 noire
 SCHRAUBE M6x25 schwarz
 TORNILLO M6x25 negra
Q.TY n.2

5

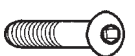
DISTANZIALE f14X17 foro 5,5 V515
 COLLAR DISTANCE
 COLLIER DE SEPARATION
 DISTANZSTÜTUCK
 SEPARADOR
Q.TY n.2

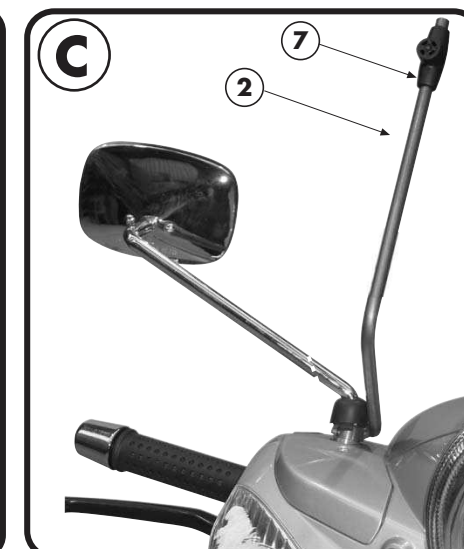
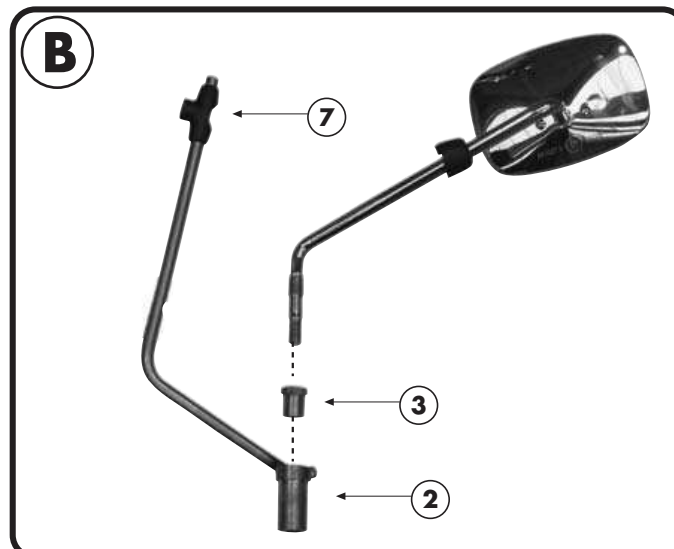
6

VITE TBEI M5x50 nera
 SCREW M5x50 black
 VIS M5x50 noire
 SCHRAUBE M5x50 schwarz
 TORNILLO M5x50 negra
Q.TY n.2





7

FASCETTA A "T" Z870
 "T" CLAMP
 COLLIER A "T"
 "T" SCHELLE
 ABRAZADERA A "T"
Q.TY n.2

8

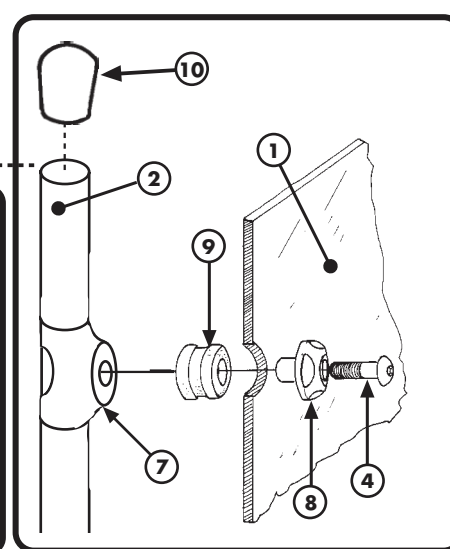
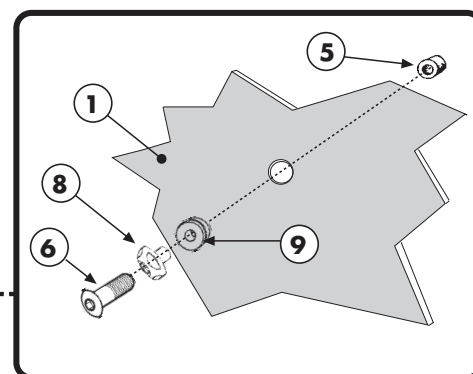
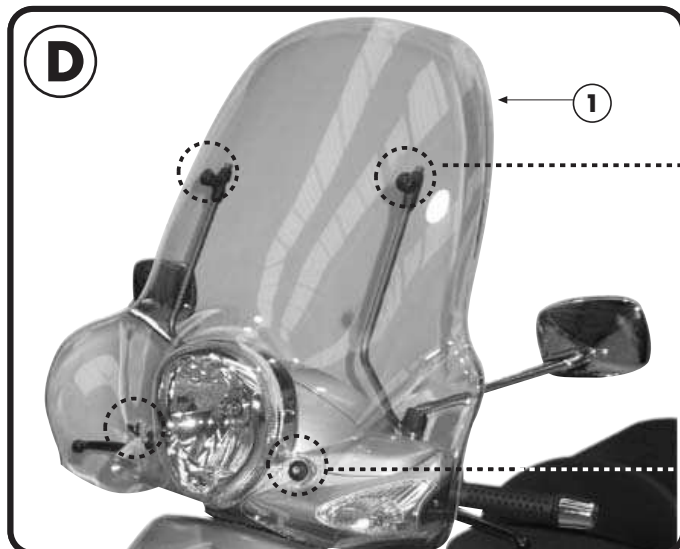
BOCCOLA DI RITENZIONE VETRO Z871
 PLASTIC BUSH
 DOUILLE PLASTIQUE
 BÜCHSE PLASTIK
 CASQUILLO
Q.TY n.4



9

GOMMINO Z268
 Z268 FAIRLEADER
 CHAUMARD Z268
 GUMMI Z268
 FUNDA Z268
Q.TY n.4

10

GOMMINO 8TAP
 RUBBER
 CAOUTCHOUC
 GUMMI
 GOMA
Q.TY n.2

ATTACCHI SPECIFICI PER 106A - SPECIFIC FITTING KIT FOR 106A
 KIT DE MONTAGE SPECIFIQUE POUR 106A - SPEZIFISCHER MONTAGEKIT F R 106A
 ANCLAJE ESPEC FICO PARA 106A

PIAGGIO BEVERLY 500 2003

ISTRUZIONI DI MONTAGGIO - MOUNTING INSTRUCTIONS
 INSTRUCTIONS DE MONTAGE - BAUANLEITUNG - INSTRUCCIONES DE MONTAJE

I ISTRUZIONI DI MONTAGGIO

1. SMONTARE GLI SPECCHI ED IL VETRO ORIGINALE
2. MANTENERE IN POSIZIONE ORIGINALE I GOMMINI CHE SERVIRANNO PER IL MONTAGGIO (rif. G)
3. ASSEMBLARE LO SPECCHIETTO CON L ATTACCO PARABREZZA E DADO SPECIALE
4. RIMONTARE GLI SPECCHIETTI CON L ATTACCO NELLA POSIZIONE ORIGINALE.
5. PROCEDERE AL MONTAGGIO DEL PARABREZZA, FOTO (D)

E MOUNTING INSTRUCTIONS

1. REMOVE THE MIRRORS AND THE ORIGINAL SCREEN.
2. HOLD THE RUBBERS IN THEIR ORIGINAL POSITION SINCE THEY ARE NEEDED FOR THE MOUNTING (PICTURE A).
3. ASSEMBLE THE MIRROR TOGETHER WITH THE SCREEN FITTING AND THE SPECIAL NUT (PICTURE B).
4. REASSEMBLE THE MIRRORS WITH THE SCREEN FITTING IN THEIR ORIGINAL POSITION (PICTURE C).
5. PROCEED WITH THE MOUNTING OF THE SCREEN, AS SHOWN IN PICTURE D.

F INSTRUCTIONS DE MONTAGE

1. DEMONTER LES RETROVISEURS ET LE PARE-BRISE D'ORIGINE
2. MAINTENIR EN POSITION HORIZONTALE LES CAOUTCHOUCS QUI SERVIRONT POUR LE MONTAGE (PHOTO A)
3. ASSEMBLER LE RETROVISEUR AVEC LA FIXATION DU PARE-BRISE ET L'ECROU SPECIAL (PHOTO B)
4. REMONTER LES RETROVISEURS AVEC LES FIXATIONS DANS LA POSITION ORIGINALE (PHOTO C)
5. PROCEDER AU MONTAGE DU PARE-BRISE COMME INDIQUE SUR LA PHOTO D.

D BAUANLEITUNG

1. MONTIEREN SIE DIE SPIEGEL UND DIE ORIGINALSCHEIBE AB.
2. LASSEN SIE DIE GUMMIS IN IHRER ORIGINALPOSITION, DA SIE FÜR DIE WEITERMONTAGE DER SCHEIBE VERWENDET WERDEN MÜSSEN. (BILD A).
3. JETZT MONTIEREN SIE DEN SPIEGEL MIT DEM VERBINDUNGSTEIL VON DEM BEFESTIGUNGSKIT ZUSAMMEN (BILD B).
4. MONTIEREN SIE DIE SPIEGEL IN IHRER ORIGINAL POSITION WIEDER AN (BILD C).
5. GEHEN SIE JETZT MIT DER MONTAGE DER SCHEIBE WEITER, WIE IM BILD D GEZEIGT WIRD.

ES

INSTRUCCIONES DE MONTAJE

- 1.- DESMONTAR LOS RETROVISORES Y LA PANTALLA ORIGINAL.
- 2.- MANTENER EN LA POSICIÓN ORIGINAL LAS GOMAS QUE SERVIRÁN PARA EL MONTAJE (Ref. G) FOTO A.
- 3.- ENSAMBLAR LOS RETROVISORES CON EL ANCLAJE DEL PARABRISAS Y TORNILLOS ESPECIALES. FOTO B.
- 4.- MONTAR LOS RETROVISORES CON EL ANCLAJE EN LA POSICIÓN ORIGINAL. FOTO C.
- 5.- PROCEDER AL MONTAJE DEL PARABRISAS, SEGÚN FOTO D.