

ATTACCHI SPECIFICI PER - SPECIFIC FITTING KIT FOR
KIT DE MONTAGE SPECIFIQUE POUR - SPECIFISCHER MONTAGEKIT FÜR
ANCLAJE ESPECIFICO PARA

BMW R1200GS 2004

ISTRUZIONI DI MONTAGGIO - MOUNTING INSTRUCTIONS
INSTRUCTIONS DE MONTAGE - BAUANLEITUNG - INSTRUCCIONES DE MONTAJE

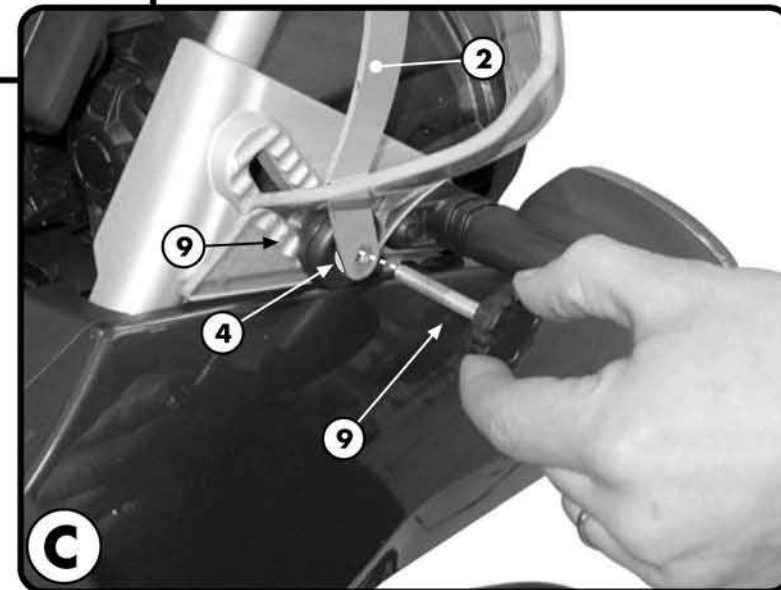
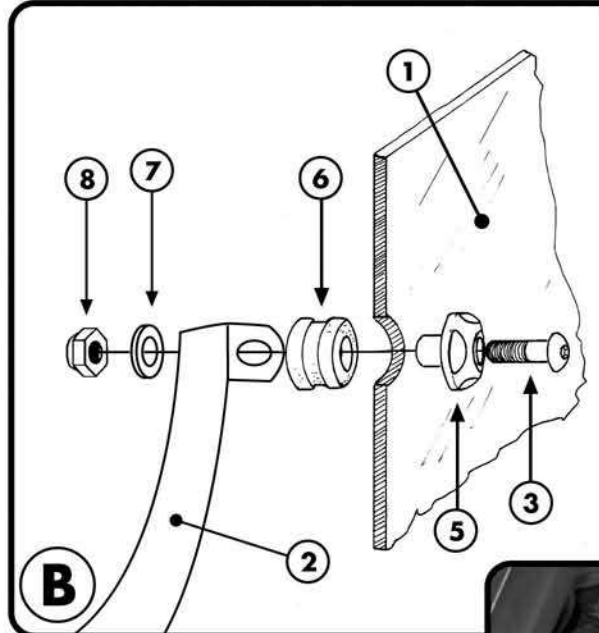
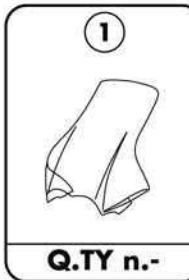
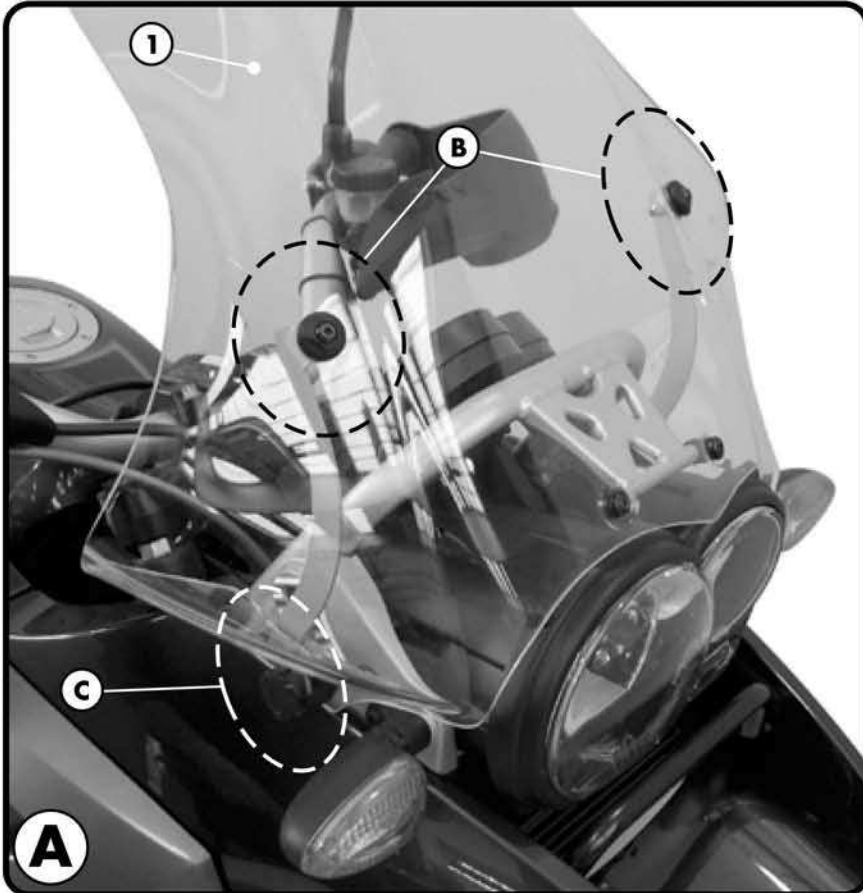

D330KIT-D330KIT

ATTACCHI SPECIFICI PER - SPECIFIC FITTING KIT FOR
KIT DE MONTAGE SPECIFIQUE POUR - SPEZIFISCHER MONTAGEKIT FÜR
ANCLAJE ESPECÍFICO PARA

BMW R1200GS 2004

ISTRUZIONI DI MONTAGGIO - MOUNTING INSTRUCTIONS
INSTRUCTIONS DE MONTAGE - BAUANLEITUNG - INSTRUCCIONES DE MONTAJE

I ISTRUZIONI DI MONTAGGIO

1. SMONTARE IL PARABREZZA ORIGINALE;
2. POSIZIONARE IL PARTICOLARE N°1 (NON INCLUSO) COME INDICATO IN FOTO A;
3. FISSARE I SUPPORTI N°2 COME INDICATO IN FOTO A FACENDOLI PASSARE NELLE APPOSITE ASOLE CREATE AI LATI DEL PARABREZZA;
4. FARE RIFERIMENTO AL DISEGNO B ED ALL'IMMAGINE C PER IL FISSAGGIO DEI SUPPORTI N°2;
5. SMONTARE DAL PARABREZZA ORIGINALE E RIMONTARE SUL NUOVO TUTTI I DISTANZIALI E RONDELLE IN PLASTICA;
6. ULTIMARE IL MONTAGGIO CONTROLLANDO IL CORRETTO SERRAGGIO DELLE VITI.

GB MOUNTING INSTRUCTIONS

1. REMOVE THE ORIGINAL WINDSCREEN;
2. PLACE THE PART N° 1 (NOT INCLUDED) AS SHOWN IN PICTURE A;
3. FIX THE SUPPORTS N°2 AS SHOWN IN PICTURE A; INSERT THEM IN THE SLOTS AT THE SIDES OF THE WINDSCREEN;
4. MAKE REFERENCE TO THE DRAWING B AND TO PICTURE C FOR FIXING THE SUPPORTS N° 2;
5. REMOVE FROM THE ORIGINAL WINDSCREEN ALL OF THE ORIGINAL SPACERS AND PLASTIC WASHERS AND MOUNT THEM TO THE NEW WINDSCREEN;
6. LASTLY CHECK THAT ALL SCREWS HAVE BEEN TIGHTENED.

F INSTRUCTIONS DE MONTAGE

1. DEMONTER LE PARE BRISE D'ORIGINE;
2. POSITIONNER LA PIECE N°1 (NON INCLUSE) COMME INDIQUE SUR LA PHOTO A;
3. FIXER LES UPPORTS N°2 COMME INDIQUE SUR LA PHOTO A EN LES FAISANT PASSER PAR LES TROUS DECOUPES SUR LES COTES DU PARE BRISE;
4. SE REFERER AU CROQUIS B ET A L'IMAGE C POUR LA FIXATION DES SUPPORTS N°2;
5. RECUPERER SUR LE PARE BRISE D'ORIGINE LES ENTRETOISES ET LES RONDELLES EN PLASTIQUE ET LES REMONTER SUR LE NOUVEAU PARE BRISE;
6. FINIR LE MONTAGE EN CONTROLANT LE BON SERRAGE DE TOUTES LES VIS.

D BAUANLEITUNG

1. MONTIEREN SIE DIE ORIGINALSCHEIBE AB;
2. POSITIONIEREN SIE DAS TEIL NR. 1 (NICHT VORHANDEN) WIE IM BILD A BESCHRIEBEN;
3. BEFESTIGEN SIE DIE HALTERUNGEN NR. 2 WIE IM BILD A BESCHRIEBEN; UND STECKEN SIE DIESE IN DEN OSEN AN DEN SEITEN DES WINDSCHILDES;
4. NEHMEN SIE BEZUG AUF DIE ZEICHNUNG B UND AUF DAS BILD C FÜR DIE BEFESTIGUNG DER HALTERUNGEN NR. 2;
5. MONTIEREN SIE DIE ORIGINAL DISTANZSTÜCKE UND UNTERLEGSCHLEIBEN AUF DEM NEUNEN WINDSCHILD;
6. ZULETZT ZIEHEN SIE ALLE SCHRAUBEN FEST.

ES

INSTRUCCIONES DE MONTAJE

1. DESMONTAR EL PARABRISAS ORIGINAL; CONSERVANDO TODA LA TORNILLERÍA ORIGINAL;
2. MONTAR LA PANTALLA N° 1 (NO INCLUIDA - SE VENDE POR SEPARADO) COMO INDICA LA FOTO A; ANCLAR LOS SOPORTES N° 2 COMO INDICA LA FOTO A PONIENDO ATENCION AL MONTAJE INDICADO AL PUNTO 3 Y PASANDO POR EL AGUJERO CREADO EN LOS LADOS DE LA PANTALLA;
3. PARA ANCLAR LOS SOPORTES N° 2 SEGUIR EL MONTAJE INDICADO EN EL DISEÑO B Y EN LA FOTO C;
4. MONTAR SOBRE EL PARABRISAS TODAS LAS ARANDELAS Y LOS DISTANCIADORES ORIGINALES DESMONTADOS AL PUNTO 1.;
5. TERMINAR APRETANDO TODOS LOS TORNILLOS.