

MONORACK SPECIFICO - SPECIFIC MONORACK  
MONORACK SPECIFIQUE - SPEZIFISCHES MONORACK - MONORACK ESPECÍFICO

# KAWASAKI ER-6n '05/'08

ISTRUZIONI DI MONTAGGIO - MOUNTING INSTRUCTIONS  
INSTRUCTIONS DE MONTAGE - BAUANLEITUNG - INSTRUCCIONES DE MONTAJE

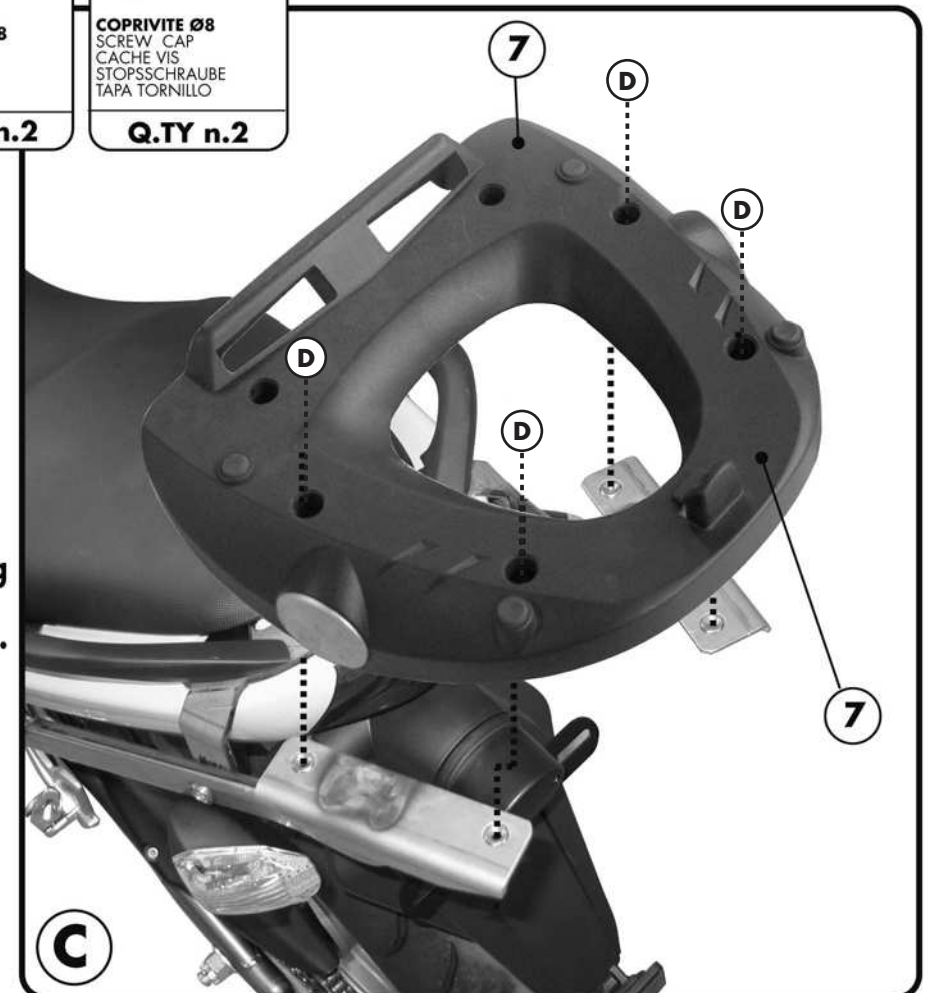
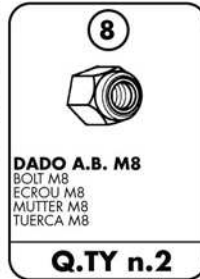
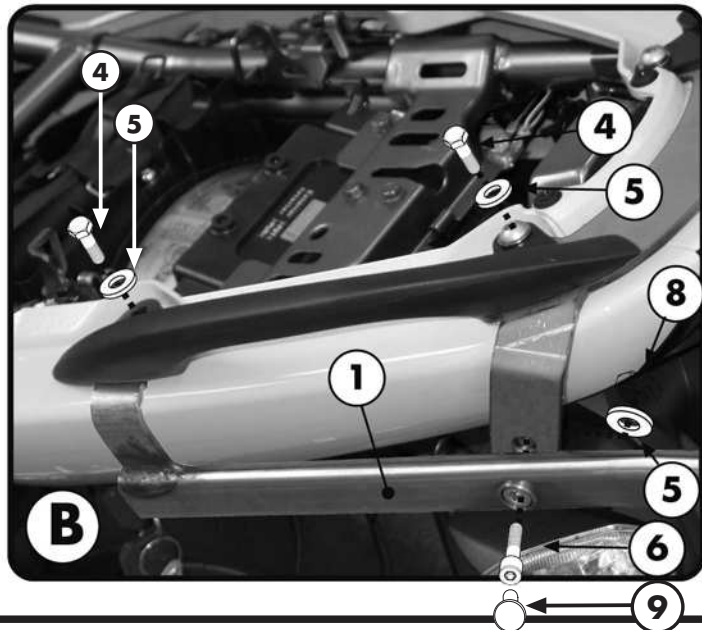
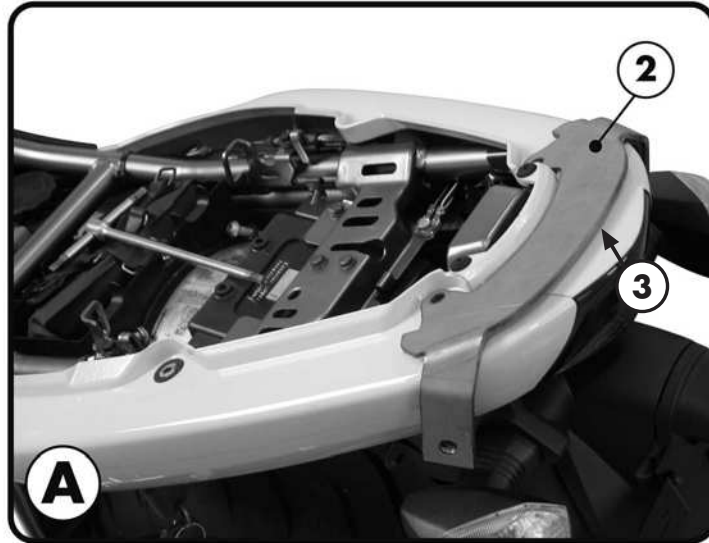

**ATTENZIONE:** CARICO MASSIMO, 6Kg.  
**WARNING:** MAX LOAD, 6Kg.  
**ATENCIÓN:** CARGA MÁXIMA, 6Kg.  
**ACHTUNG:** MAX, 6Kg.  
**¡ATENCIÓN!** CARGA MÁXIMA, 6Kg.

MONORACK SPECIFICO - SPECIFIC MONORACK  
 MONORACK SPECIFIQUE - SPEZIFISCHES MONORACK - MONORACK ESPECÍFICO

# KAWASAKI ER-6n '05/'08

ISTRUZIONI DI MONTAGGIO - MOUNTING INSTRUCTIONS  
 INSTRUCTIONS DE MONTAGE - BAUANLEITUNG - INSTRUCCIONES DE MONTAJE

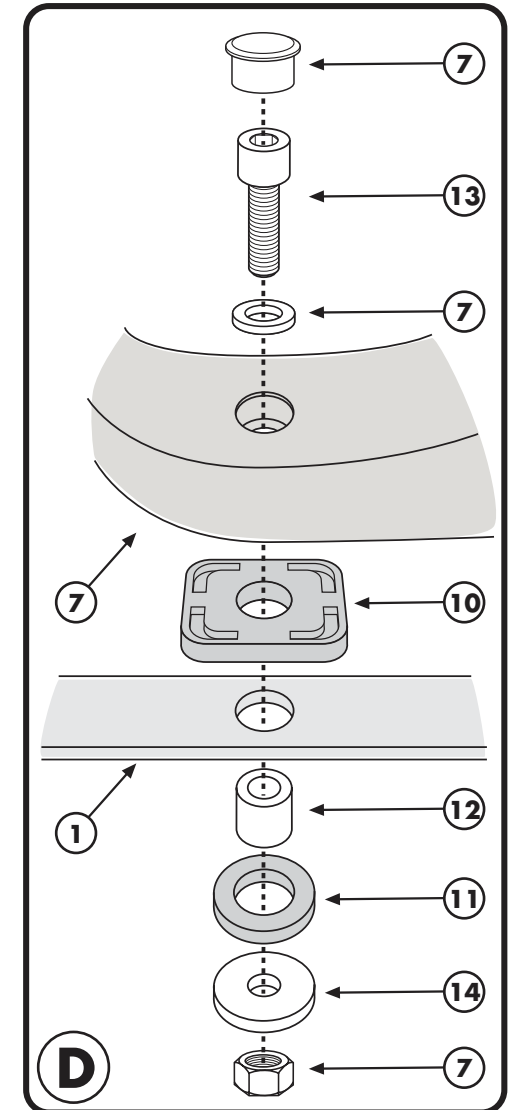
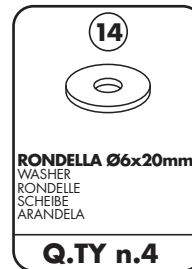
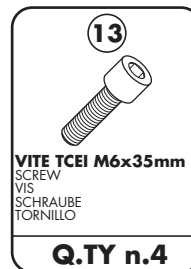
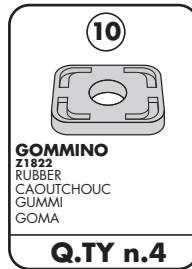

MONORACK SPECIFICO - SPECIFIC MONORACK  
MONORACK SPECIFIQUE - SPEZIFISCHES MONORACK - MONORACK ESPECÍFICO

**KAWASAKI ER-6n '05/'08**

ISTRUZIONI DI MONTAGGIO - MOUNTING INSTRUCTIONS  
INSTRUCTIONS DE MONTAGE - BAUANLEITUNG - INSTRUCCIONES DE MONTAJE

## I ISTRUZIONI DI MONTAGGIO

- SMONTARE LE MANIGLIE ORIGINALI DELLA MOTO;
- INCOLLARE LA MOUSSE ADESIVA SULLA PARTE DEL SUPPORTO "2" CHE VA A CONTATTO CON LA CARENATURA DELLA MOTO;
- POSIZIONARE IL SUPPORTO "2" COME INDICATO IN FIGURA "A";
- POSIZIONARE LE STAFFE MONORACK E SEGUIRE IL MONTAGGIO PROPOSTO IN FIGURA "B".
- CONTROLLARE CHE TUTTE LE VITI SIANO SERRATE BENE.

## GB MOUNTING INSTRUCTIONS

1. REMOVE THE ORIGINAL HANDLE BARS;
2. PLACE THE SUPPORT N° 2 AS SHOWN IN PICTURE A, STICKING THE PROTECTIVE RUBBER PADS ONTO THE SUPPORT WHERE IT COMES INTO CONTACT WITH THE FARING;
3. POSITION THE MONORACK ARMS AND CARRY OUT THE MOUNTING INSTRUCTIONS SHOWN IN PICTURE B;
4. LASTLY CHECK THAT ALL SCREWS HAVE BEEN TIGHTENED.

## F INSTRUCTIONS DE MONTAGE

- DEMONTER LES POIGNEES PASSAGER D'ORIGINE DE LA MOTO ;  
COLLER LA MOUSSE ADHESIVE SUR LA PARTIE DU SUPPORT N°2 QUI SERA EN CONTACT AVEC LA CARROSSERIE DE LA MOTO;  
POSITIONNER LE SUPPORT N°2 COMME INDIQUE EN PHOTO A ;  
POSITIONNER LES BRAS DU MONORACK ET FAIRE LE MONTAGE PROPOSE EN PHOTO B ;  
CONTROLLER LE BON SERRAGE DE TOUTES LES VIS ;

## D BAUANLEITUNG

- ENTFERNEN SIE DIE ORIGINAL HANDGRIFFE DES FAHRZEUGS;  
KLEBEN SIE DEN SCHUTZGUMMI AUF DIE HALTERUNG NR. 2, DIE DIE VERKLEIDUNG DES FAHRZEUGES BERÜHRT;  
POSITIONIEREN SIE DIE HALTERUNG NR. 2 WIE IM BILD  
A BESCHRIEBEN;  
POSITIONIEREN SIE DIE MONORACK ARME UND FOLGEN SIE DER MONTAGEANLEITUNG VOM BILD B;  
ZULETZT ÜBERPRÜFEN SIE, DASS ALLE SCHRAUBEN FESTGEZOGEN WURDEN.

## ES

## INSTRUCCIONES DE MONTAJE

1. DESMONTAR EL ASA ORIGINAL DE LA MOTO;
2. ENCOLAR LA CAPA ADHESIVA SOBRE LA PARTE DEL SOPORTE 2 AL CARENADO TRASERO;
3. POSICIONAR EL SOPORTE N. 2 COMO INDICA LA FOTO A;
4. POSICIONAR LOS BRAZOS DEL MONORACK Y SEGUIR EL MONTAJE ILUSTRADO EN LA FIGURA B;
5. CONTROLAR QUE TODA LA TORTILLERIA HA SIDO BIEN APRETADA.