

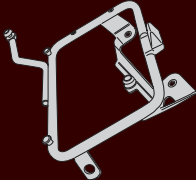







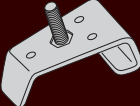

# PLR1110 - KLR1110

PORTAVALIGIE LATERALE SPECIFICO - SPECIFIC TUBULAR SIDE-CASE HOLDER - PORTE-VALISES LATÉRAUX SPÉCIFIQUE - SPEZIFISCHES STAHLROHR-SEITENTRAEGER  
 PORTA MALETAS LATERALES ESPECÍFICO

## HONDA CROSSTOURER 1200 (2012)

N°	Descrizione	Caratteristiche	Codice	Quantità	
1	Supporto - Support - Support Halterung - Soporte	-	-	2 (Dx,Sx)	
2	Ponte Posteriore - Rear Bridge - Pont Postérieure Verbindungsrohr - Puente Trasero	-	-	1	
3	Supporto - Support - Support Halterung - Soporte	-	GL2111	2 (Dx,Sx)	
4	Supporto - Support - Support Halterung - Soporte	-	GL2113	2 (Dx,Sx)	
5	Supporto - Support - Support Halterung - Soporte	-	GL2114	2 (Dx,Sx)	
6	Supporto - Support - Support Halterung - Soporte	-	GL2112	2 (Dx,Sx)	
7	Vite - Screw Vis - Schraube - Tornillo	TBEI M6x45	-	2	
8	Dado - Bolt - Ecrou Mutter - Tuerca	Auto Bloccante Flangiato M8	-	4	
9	Dado - Bolt - Ecrou Mutter - Tuerca	Auto Bloccante Flangiato Ribassato M6	-	2	
10	Distanziale - Spacer Entretaise - Distanzstueck Distanciador	Tubetto Ø10x1.5x24mm	V784	2	
11	Chiave Per Viti A Testa Speciale Special Key - Cle Speciale Spezialschlüssel Zur Demontage Des Trägers Llave Para Tornillos Con Cabeza Especial	-	-	1	
12	Protezione Adesiva - Adhesive Protection Protection Adhesive - Schutzkleber Protección Adhesiva	1 x 160mm (cut in 4 pcs)	-	-	



# PLR1110 - KLR1110

PORTAVALIGIE LATERALE SPECIFICO - SPECIFIC TUBULAR SIDE-CASE HOLDER - PORTE-VALISES LATÉRAUX SPÉCIFIQUE - SPEZIFISCHES STAHLROHR-SEITENTRAEGER  
PORTA MALETAS LATERALES ESPECÍFICO

## HONDA CROSSTOURER 1200 (2012)

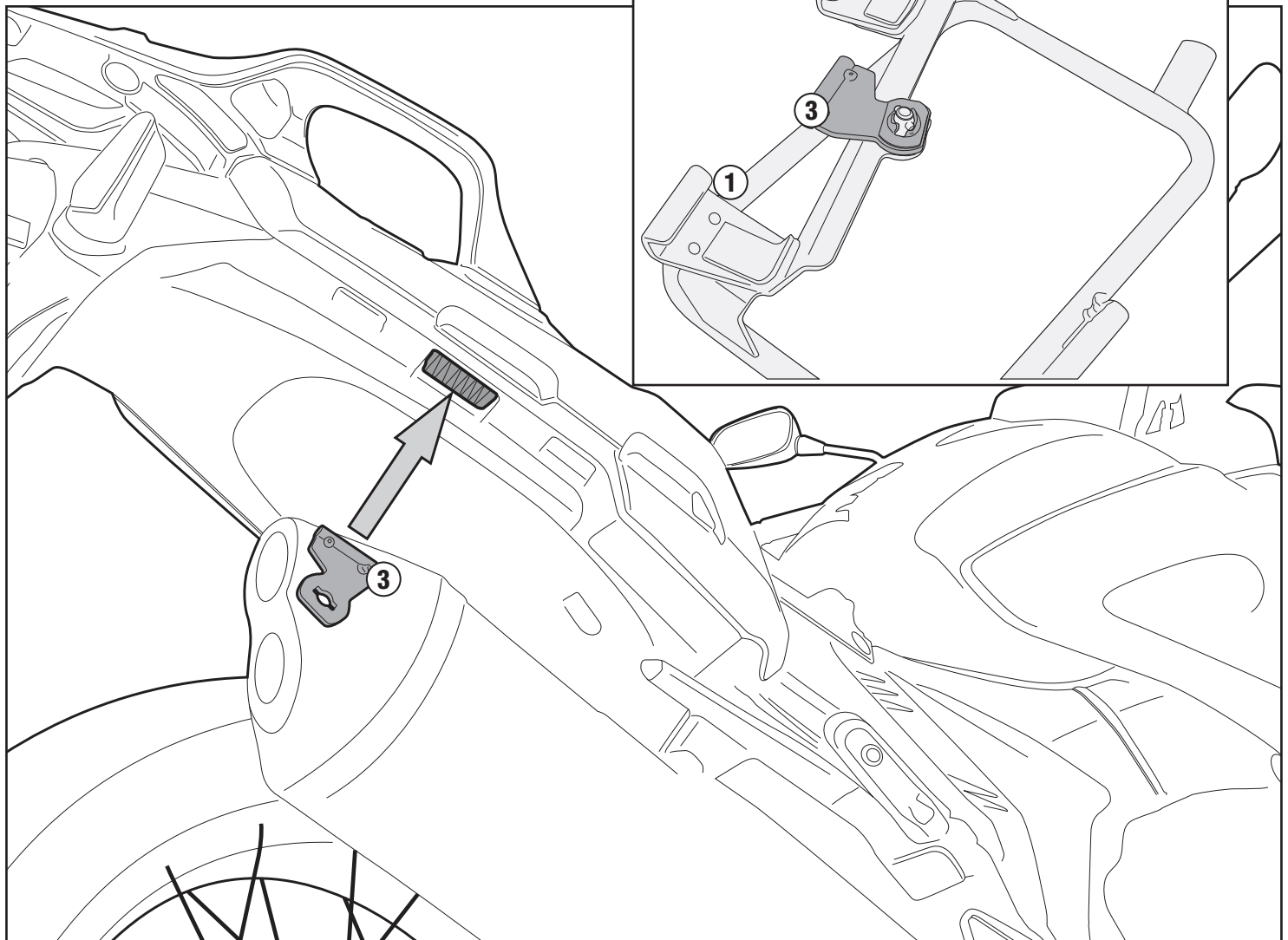
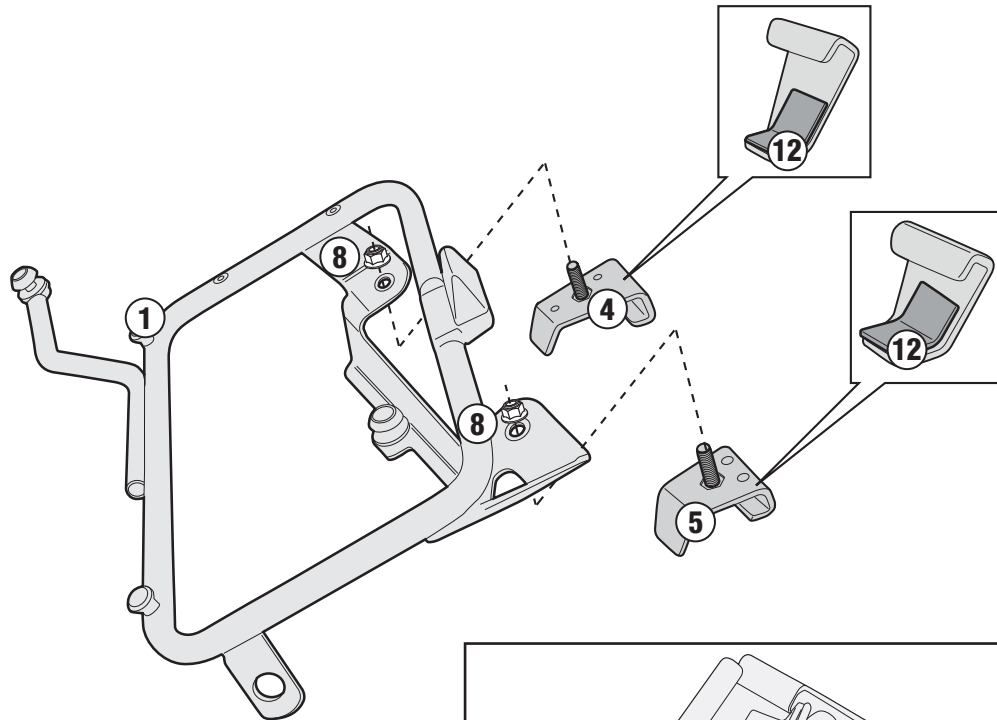

# PLR1110 - KLR1110

PORTAVALIGIE LATERALE SPECIFICO - SPECIFIC TUBULAR SIDE-CASE HOLDER - PORTE-VALISES LATÉRAUX SPÉCIFIQUE - SPEZIFISCHES STAHLROHR-SEITENTRAEGER  
PORTA MALETAS LATERALES ESPECÍFICO

## HONDA CROSSTOURER 1200 (2012)

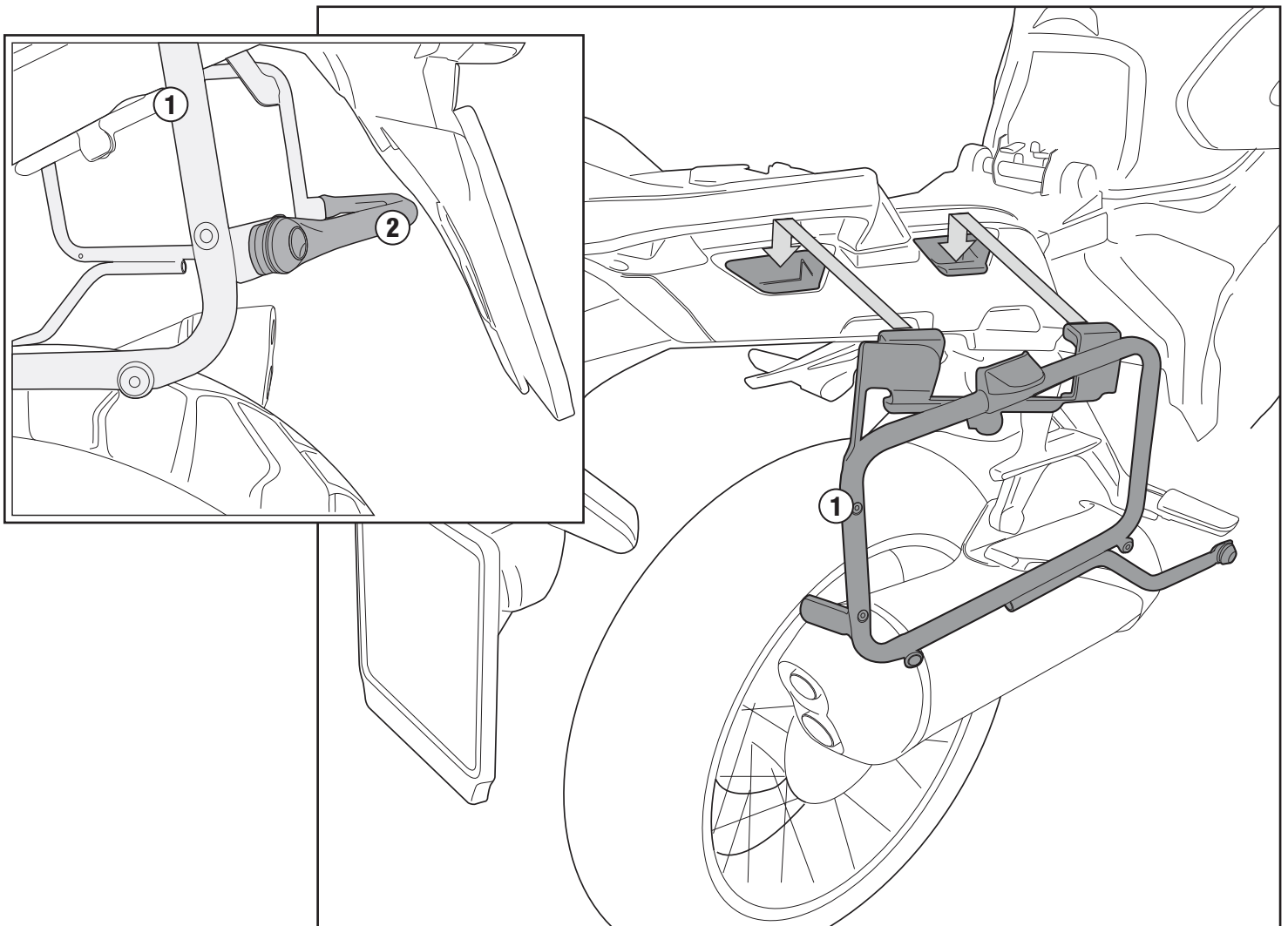
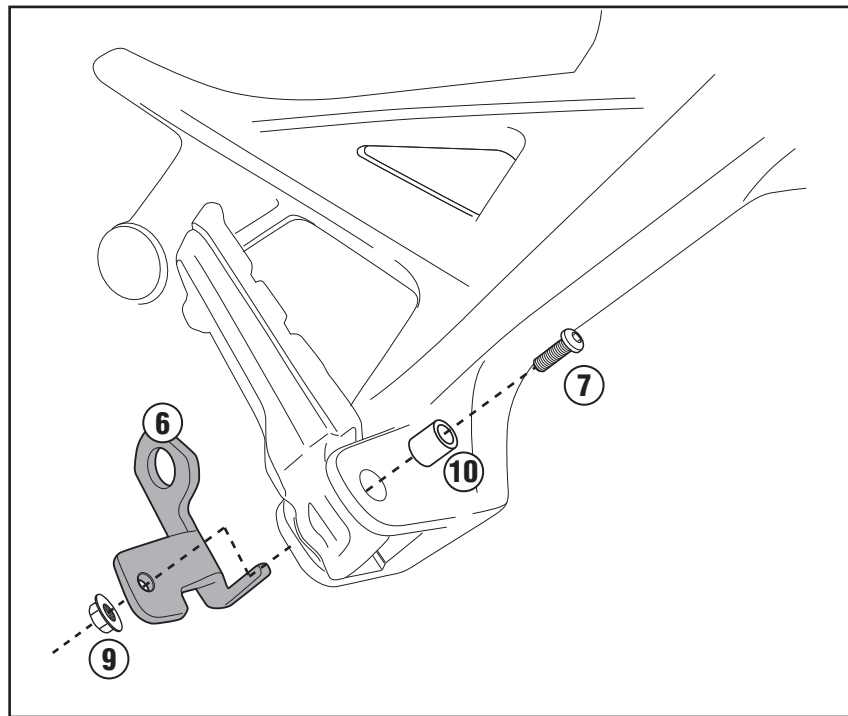

## MONTAGGIO / SMONTAGGIO PORTAVALLIGE LATERALE VERSIONE PLXR "RAPID"



- I**
1. INSERIRE L'ATTREZZO NELLA TESTA DELLA VITE SPECIALE;
  2. RUOTARE DI 1/4 DI GIRO IN SENSO ORARIO FINO A CHE LA ROTAZIONE NON TERMINA E SI AVVERTE LO SCATTO;
  3. PER SMONTARE PROCEDERE IN SENSO INVERSO.

- GB**
1. INSERT THE SPECIAL KEY INTO THE HEAD OF THE SCREW;
  2. TURN THE KEY 1/4 TURN CLOCKWISE UNTIL ROTATION STOPS AND THE SIDE CASE HOLDER IS FASTENED SECURELY TO THE FITMENT POINT;
  3. IN ORDER TO DISASSEMBLE THE BRACKETRY PERFORM THE OPERATION IN REVERSE.

- F**
1. INSERER LA CLE SPECIALE DANS LA TÊTE DE LA VIS;
  2. VISSER D'1/4 DE TOUR DANS LE SENS HORAIRE JUSQU'AU BLOCCAGE DE LA VIS POUR MONTER EN TOUTE SECURITE LE SUPPORT A SON POINT DE FIXATION;
  3. POUR LE DEMONTAGE, PROCEDER EN SENSE INVERSE.

- D**
1. STECKEN SIE DAS WERKZEUG IN DEN KOPF DER SPEZIFISCHEN SCHRAUBE;
  2. DREHEN SIE DIE SCHRAUBE 1/4 UMDREHUNG IM UHRZEIGERSINN BIS SIE BEMERKEN, DASS DIE SCHRAUBE IM BEFESTIGUNGSPUNKT ENGEKLEMMT IST;
  3. FÜR DIE DEMONTAGE FOLGEN SIE DEN HINWEISE UMGEGEHRT.

- ES**
1. INSERTAR LA LLAVE ESPECIAL EN LA CABEZA DEL TORNILLO
  2. DAR 1/4 DE VUELTA EN EL SENTIDO HORARIO HASTA QUE LLEGUE AL TOPE Y SE VEA EL TORNILLO;
  3. PARA DESMONTARIO PROCEDER EN LA DIRECCIÓN CONTRARIA;



**FORO DI SICUREZZA**  
FORO PREDISPOSTO AD ASSICURARE IL PORTAVALLIGE LATERALE ALLA MOTO (CON UN LUCCHETTO PER ESEMPIO, NON INCLUSO).

**TROU DE SECURITE**  
TROU PREDISPOSE POUR ASSURER LE PORTE-VALLISE LATERAL A LA MOTO (AVEC UN CADENAS PAR EXEMPLE, NON INCLUS).

**TROU DE SECURITE**  
TROU PREDISPOSE POUR ASSURER LE PORTE-VALISE LATERAL A LA MOTO (AVEC UN CADENAS PAR EXEMPLE, NON INCLUS).

**FORO DI SICUREZZA**  
VORGESEHENES LOCH UM DEN SEITENKOFFERTRÄGER AN DEN FAHRZEUG ZU SICHERN (Z. B. MITTEN EINE VORHÄNGESCHLOSS, NICHT ENTHALTEN).

**ORIFICIO DE SEGURIDAD**  
ESTE ORIFICIO ESTÁ CREADO PARA ASEGURAR EL PORTAVALISE LATERAL A LA MOTO (POR EJEMPLO CON UN CANDADO, QUE NO ESTÁ INCLUIDO).

