

MONORACK SPECIFICO - SPECIFIC MONORACK
 MONORACK SPECIFIQUE - SPEZIFISCHES MONORACK - MONORACK ESPECÍFICO

SUZUKI

GSF 650 BANDIT 2007

ISTRUZIONI DI MONTAGGIO - MOUNTING INSTRUCTIONS - INSTRUCTIONS DE MONTAGE
 BAUANLEITUNG - INSTRUCCIONES DE MONTAJE

1



SUPPORTO
 SUPPORT
 HALTERUNG
 SOPORTE

Q.TY n.2(Dx,Sx)

2



SUPPORTO
 SUPPORT
 HALTERUNG
 SOPORTE

Q.TY n.2(Dx,Sx)

3



DISTANZIALE Ø22x17mm
 Foro Ø8,5mm, V595
 SPACER
 ENTRETÈISE
 DISTANZSTÜCK
 DISTANCIADOR

Q.TY n.2

4



DISTANZIALE Ø14x16mm
 Foro Ø8,5mm, V457
 SPACER
 ENTRETÈISE
 DISTANZSTÜCK
 DISTANCIADOR

Q.TY n.2

5



DISTANZIALE Ø32x2,5mm
 Foro Ø8,5mm, 832RON
 SPACER
 ENTRETÈISE
 DISTANZSTÜCK
 DISTANCIADOR

Q.TY n.2

6



RONDELLA Ø8x14mm
 WASHER Ø8x14mm
 RONDELLE Ø8x14mm
 SCHEIBE Ø8x14mm
 ARANDELA Ø8x14mm

Q.TY n.2

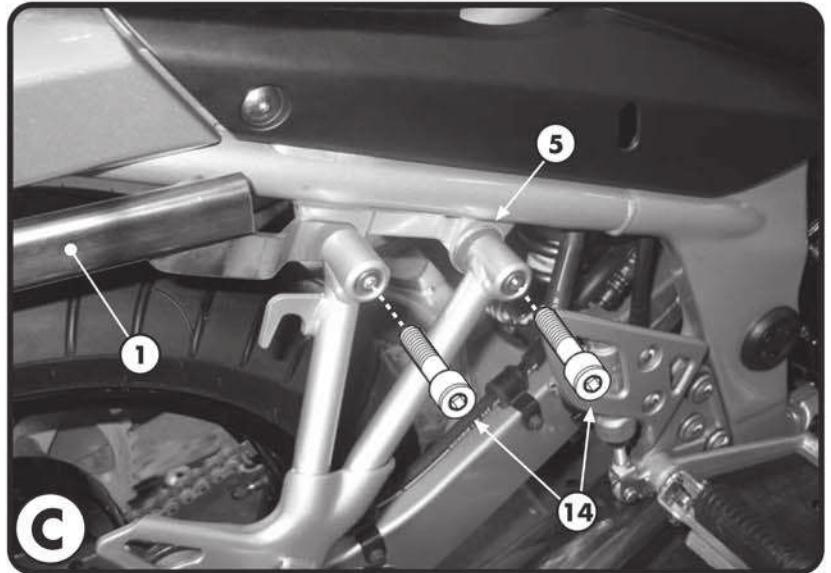
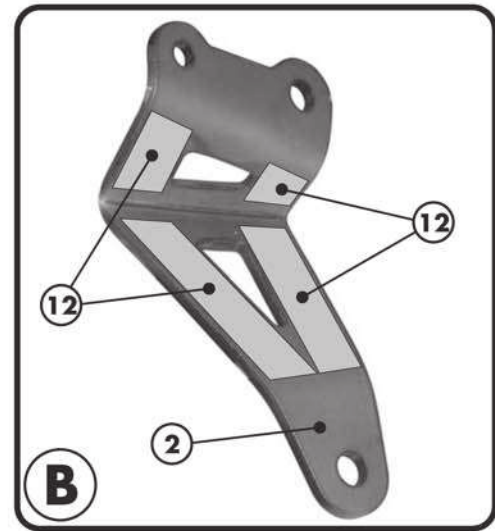
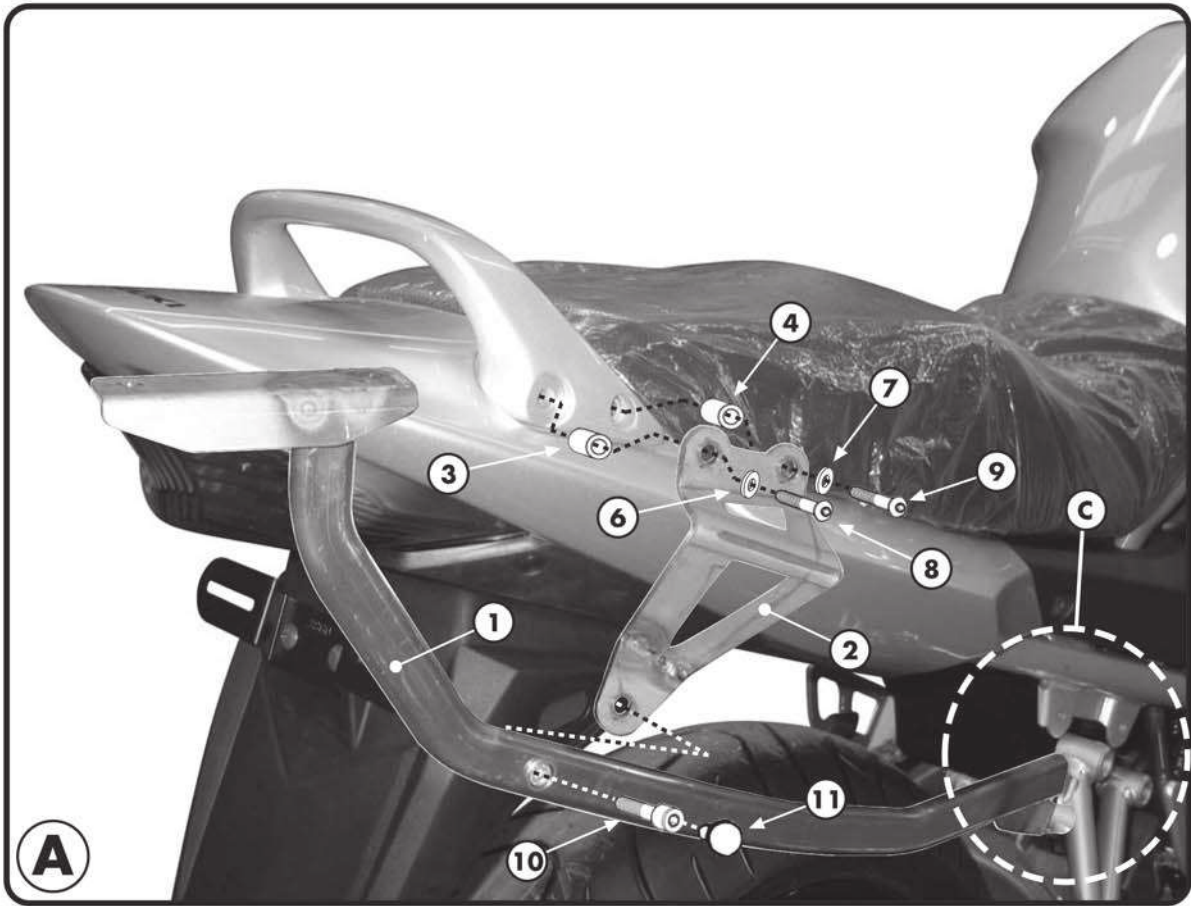

SUZUKI
GSF 650 BANDIT 2007ISTRUZIONI DI MONTAGGIO - MOUNTING INSTRUCTIONS - INSTRUCTIONS DE MONTAGE
BAUANLEITUNG - INSTRUCCIONES DE MONTAJE

10

**VITE TCEI M8x20mm**
SCREW M8x20mm
VIS M8x20mm
SCHRAUBE M8x20mm
TORNILLO M8x20mm**Q.TY n.2**

11

**COPRIVITE Ø8mm**
Z801
SCREW CAP
CACHE VIS
STOPFSCHRAUBE
TAPA TORNILLO**Q.TY n.2**

12

**MOUSSE PROTETTIVA**
MOUSSE4
PROTECTIVE RUBBER PADS
MOUSSE DE PROTECTION
SCHUTZGUMMI
GOMA ADHESIVA
PROTECTORA**Q.TY n.1**

13

**PARTICOLARI INCLUSI NEL
KIT VITERIA DELLA PIASTRA**
COMPONENTS INCLUDED IN
THE FITTING KIT OF THE PLATE
PIÈCES INCLUSES DANS LE KIT
DE VIS DE LA PLATINE
DIE EINZELNEN TEILE SIND BEI
MONTAGEKIT DER PLATTE
ENTHALTEN
PIEZAS INCLUIDAS EN EL KIT
DE TORNILLERIA DE LA PARRILLA**Q.TY n.-**

14

COMPONENTI ORIGINALI
ORIGINAL PARTS
PARTIES ORIGINALES
ORIGINAL BAUTEILE
COMPONENTES ORIGINALES**Q.TY n.-**

7

**RONDELLA Ø6mm**
WASHER Ø6mm
RONDELLE Ø6mm
SCHEIBE Ø6mm
ARANDELA Ø6mm**Q.TY n.2**

8

**VITE TBEI M8x70mm**
SCREW M8x70mm
VIS M8x70mm
SCHRAUBE M8x70mm
TORNILLO M8x70mm**Q.TY n.2**

9

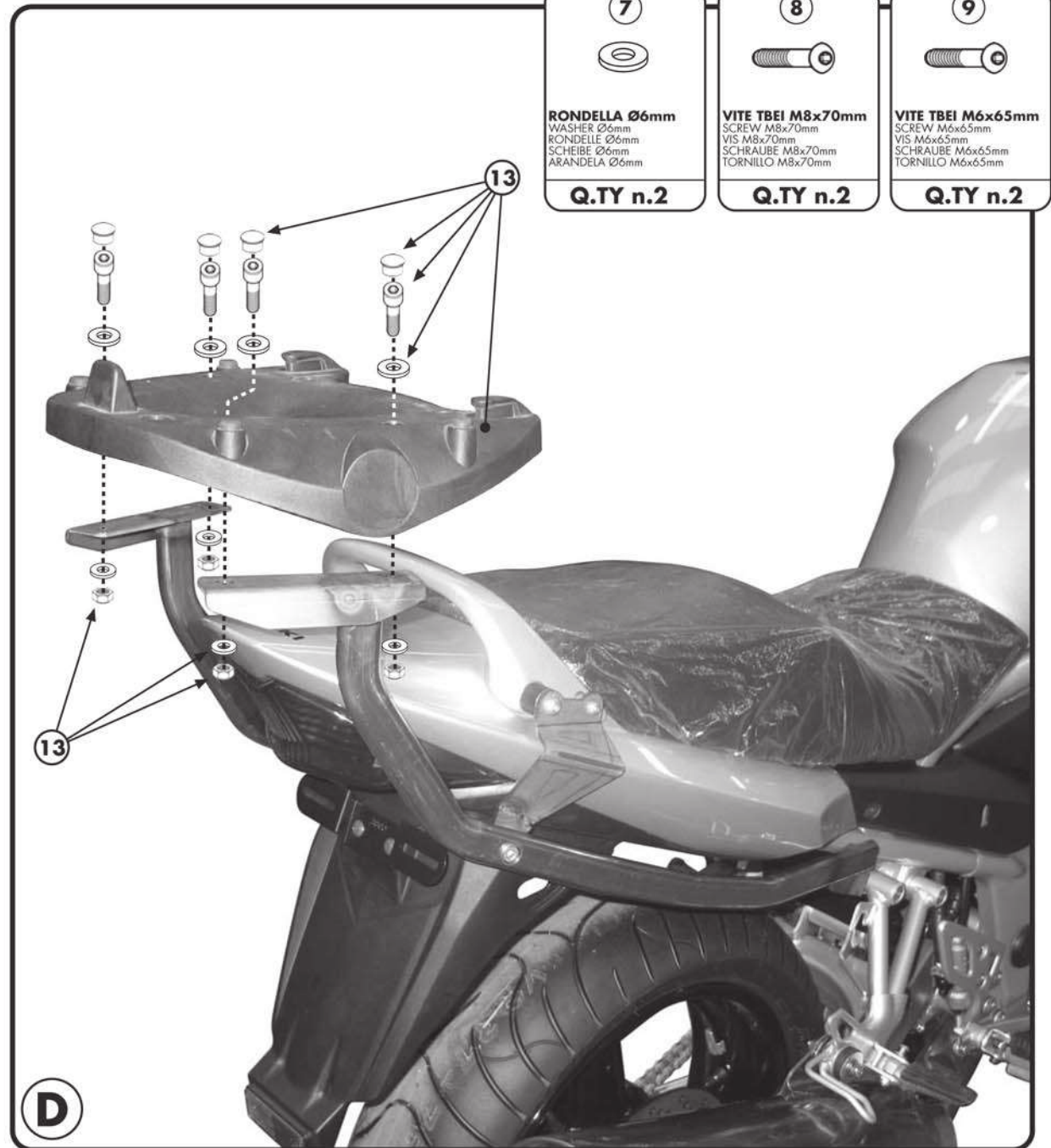
**VITE TBEI M6x65mm**
SCREW M6x65mm
VIS M6x65mm
SCHRAUBE M6x65mm
TORNILLO M6x65mm**Q.TY n.2**

SUZUKI
GSF 650 BANDIT 2007**I ISTRUZIONI DI MONTAGGIO**

1. MONTARE IL SUPPORTO N°2 ED IL SUPPORTO N°1 COME INDICATO IN FITOGRAFIA A;
2. ATTENZIONE: PRIMA DI MONTARE IL SUPPORTO N°2 ALLA MOTOCICLETTA, TAGLIARE ADEGUATAMENTE E POSIZIONARE LA MOUSSE PROTEGGI CARENA (PARTICOLARE N°12) COME MOSTRATO IN FOTOGRAFIA B;
3. NEL MONTAGGIO PROPOSTO IN FOTOGRAFIA FARE RIFERIMENTO ALLA FOTOGRAFIA C PER L'ESATTO FISSAGGIO DEL MONORACK AL PEDALE DEL GRUPPO PEDANE PASSEGGERO;
4. MONTARE LA PIASTRA (NON INCLUSA) COME INDICATO IN FOTOGRAFIA D;
5. ULTIMARE IL MONTAGGIO CONTROLLANDO CHE TUTTE LE VITI SIANO SERRATE BENE.

GB MOUNTING INSTRUCTIONS

1. MOUNT THE SUPPORT N° 2 AND THE SUPPORT N° 1 AS SHOWN IN PICTURE A;
2. ATTENTION: BEFORE MOUNTING THE SUPPORT N° 2 TO THE MOTORCYCLE, CUT THE PROTECTIVE RUBBER PADS FOR THE FAIRING (N° 12) AS SHOWN IN PICTURE B;
3. TO MOUNT THE MONORACK TO THE FOOTREST STAY, MAKE REFERENCE TO PICTURE C;
4. MOUNT THE PLATE (NOT INCLUDED) AS SHOWN IN PICTURE D;
5. LASTLY CHECK THAT ALL SCREWS HAVE BEEN TIGHTENED.

F INSTRUCTIONS DE MONTAGE

1. MONTER LES SUPPORTS N°2 ET 1 COMME INDIQUE SUR LA PHOTO A ; ATTENTION : AVANT DE FIXER LES SUPPORT N°2 A LA MOTO, COUPER ET POSITIONNER LES MOUSSES DE PROTECTION DE CARROSSERIE (PIECE N°12) COMME MONTRE SUR LA PHOTO B;
3. POUR LA FIXATION DU MONORACK AUX SUPPORTS DE REPOSE PIED PASSAGER, SE REFERER A LA PHOTO C;
4. MONTER LA PLATINE (NON INCLUSE) COMME INDIQUE SUR LA PHOTO D;
5. FINIR LE MONTAGE EN CONTROLANT LE BON SERRAGE DE TOUTES LES VIS.

D BAUANLEITUNG

1. MONTIEREN SIE DIE HALTERUNGEN NR. 2 UND NR. 1 WIE IM BILD A BESCHRIEBEN;
2. ACHTUNG: BEVOR SIE DIE HALTERUNG NR. 2 AUF DAS MOTORRAD MONTIEREN, SCHNEIDEN SIE DAS SCHUTZGUMMI FÜR DIE VERKLEIDUNG (TEIL NR. 12) IN DER RICHTIGEN FORM AUS UND POSITIONIEREN SIE ES WIE IM BILD B BESCHRIEBEN;
3. FÜR DIE KORREKTE MONTAGE DES MONORACKS AN DEN FUßRASTEN NEHMEN SIE AUF BILD C BEZUG;
4. MONTIEREN SIE DIE PLATTE (NICHT VORHANDEN – SEPARAT ZU BESTELLEN) WIE IM BILD D BESCHRIEBEN;
5. ZULETZT ÜBERPRÜFEN SIE, DASS ALLE SCHRAUBEN FESTGEZOGEN WURDEN.

ES**INSTRUCCIONES DE MONTAJE**

1. MONTAR LOS SOPORTES N° 2 Y LOS BRAZOS MONORACK N° 1 COMO INDICA LA FOTO A;
2. ¡ATENCIÓN!: ANTES DE MOTAR EL SOPORTE N° 2 CORTAR Y APLICAR LA GOMA PROTECTORA DE CARENADO (DESPIEZE N° 12) COMO INDICA LA FOTO B;
3. DURANTE EL MONTAJE SEGUIR LAS INSTRUCCIONES INDICADAS EN LA FOTO C PARA COMBINAR CORRECTAMENTE LOS BRAZOS MONORACK CON LAS ESTRIBERAS DEL PASAJERO;
4. MONTAR LA PARRILLA (NO INCLUIDA – SE VENDE POR SEPARADO) COMO INDICA LA FOTO D;
5. TERMINAR APRETANDO BIEN TODOS LOS TORNILLOS