

PIASTRA SPECIFICA - SPECIFIC PLATE  
 PLATINE SPECIFIQUE - SPEZIFISCHE PLATTE - PARRILLA PORTAEQUIPAJES

# BMW R1200RT 2005

ISTRUZIONI DI MONTAGGIO - MOUNTING INSTRUCTIONS  
 INSTRUCTIONS DE MONTAGE - BAUANLEITUNG - INSTRUCCIONES DE MONTAJE

**1**  
**GL961**  
  
**PIASTRA**  
 PLATE  
 PLATINE  
 PLATTE  
 PARRILLA  
**Q.TY n.2(dx-sx)**

**2**  
**GL962**  
  
**PIASTRA**  
 PLATE  
 PLATINE  
 PLATTE  
 PARRILLA  
**Q.TY n.2(dx-sx)**

**3**  
  
**MOUSSE**  
 MOUSSESEGUMMI  
 MOUSSE  
**Q.TY n.1**

**4**  
**GL963**  
  
**PIASTRINA**  
 PLATE  
 PLATINE  
 PLATTE  
 PARRILLA  
**Q.TY n.2(dx-sx)**

**5**  
  
**VITE TCEI M6x45mm**  
 SCREW M6x45mm  
 VIS M6x45mm  
 SCHRAUBE M6x45mm  
 TORNILLO M6x45mm  
**Q.TY n.4**

**6**  
  
**RONDELLA Ø6mm**  
 WASHER Ø6mm  
 RONDELLE Ø6mm  
 SCHEIBE Ø6mm  
 ARANDELA Ø6mm  
**Q.TY n.4**

**7**  
**GN522**  
  
**PIASTRINA**  
 LITTLE PLATE  
 PETITE PLAQUE  
 PLAETTCHEN  
 PLAGUETA  
**Q.TY n.4**

**8**  
  
**V601**  
**DISTANZIALE Ø12x26mm**  
 SPACER  
 ENTRETOISE  
 DISTANZSTUECK  
 DISTANCIADOR  
**Q.TY n.4**

**9**  
**Z400**  
  
**PIASTRA MONOKEY E250**  
 PLATE  
 PLATINE  
 PLATTE  
 PARRILLA  
**Q.TY n.1**

**10**  
**Z401**  
  
**COPRIPIASTRA**  
 COVER PLATE  
 COUVRE PLATINE  
 ABDECKPLATTE  
 CUBRE PARRILLA  
**Q.TY n.1**

**11**  
**Z872**  
  
**TAPPO ANTIFURTO**  
 ANTI-THEFT CAP  
 BOUCHON ANTIVOL  
 DIEBSTAHLSICHERUNG  
 TAPON ANTIRROBO  
**Q.TY n.1**

**12**  
**Z821**  
  
**GOMMINO**  
 RUBBER  
 CAOUTCHOUC  
 GUMMI  
 GOMA  
**Q.TY n.4**

**13**  
  
**VITE TCTC 2,2x13mm**  
 Nera KNIP  
 SCREW  
 VIS  
 SCHRAUBE  
 TORNILLO  
**Q.TY n.4**

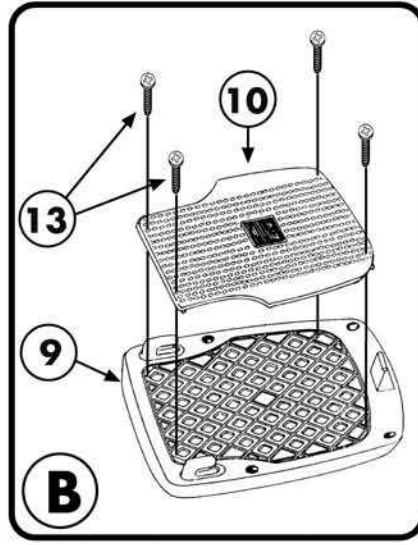
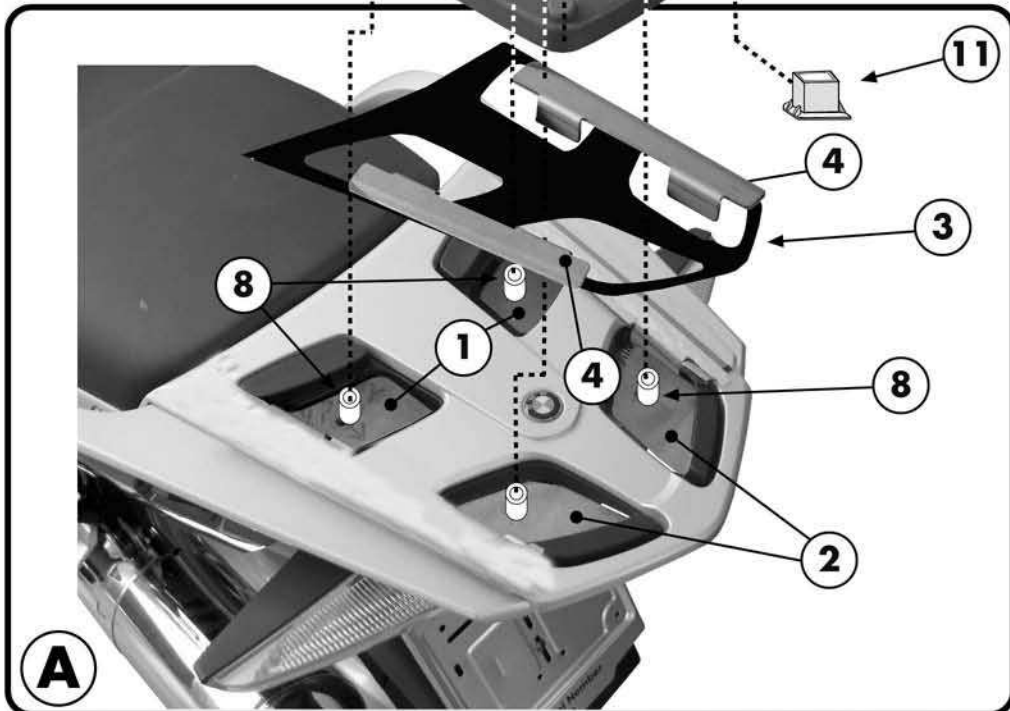
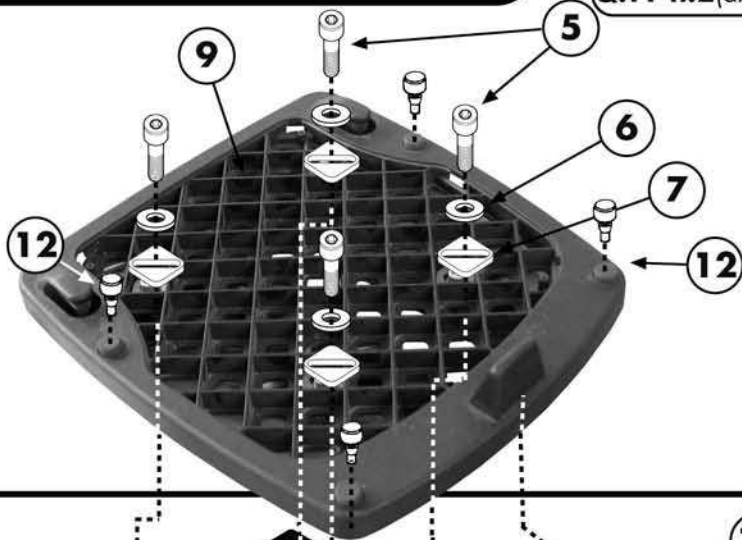

PIASTRA SPECIFICA - SPECIFIC PLATE  
 PLATINE SPECIFIQUE - SPEZIFISCHE PLATTE - PARRILLA PORTAEQUIPAJES

**BMW R1200RT 2005**

ISTRUZIONI DI MONTAGGIO - MOUNTING INSTRUCTIONS  
 INSTRUCTIONS DE MONTAGE - BAUANLEITUNG - INSTRUCCIONES DE MONTAJE

## I ISTRUZIONI DI MONTAGGIO

- 1) POSIZIONARE LE PIASTRINE 1, 2 E 4 COME INDICATO IN FIGURA A;
- 2) POSIZIONARE LA MOUSSE 3, I DISTANZIALI 8 E LA PIASTRA MONOKEY;
- 3) AVVITARE LE VITI 5 RICORDANDOSI DI METTERE LE PIASTRINE 7 E LE RONDELLE 6 COME INDICATO IN FIGURA A;
- 4) POSIZIONARE IL COPRIPIASTRA 10 SULLA PIASTRA MONOKEY 9 ED AVVITARE LE VITI 13 COME IN FIGURA B.

## GB MOUNTING INSTRUCTIONS

1. PLACE THE SMALL PLATES N° 1, 2 AND 4 AS SHOWN IN PICTURE A;
2. PLACE THE PROTECTIVE RUBBER N° 3, THE SPACERS N° 8 AND THE MONOKEY PLATE AS SHOWN IN PICTURE A;
3. SCREW THE SCREWS N° 5 WITHOUT FORGETTING TO INSERT THE SMALL PLATES N° 7 AND THE WASHERS N° 6 AS SHOWN IN PICTURE A;
4. PLACE THE COVER PLATE N° 10 ONTO THE MONOKEY PLATE N° 9 AND SCREW THE SCREWS N° 13 AS SHOWN IN PICTURE B.

## F INSTRUCTIONS DE MONTAGE

1. POSITIONNER LES PLATINES N°1, 2 ET 4 COMME INDIQUE SUR LA PHOTO A ;
2. METTRE LA MOUSSE N°3, LES ENTRETOISES N°8 ET LA PLATINE MONOKEY;
3. VISSER LES VIS N°5 SANS OUBLIER DE METTRE LES PLAQUETTES N°7 ET LES RONDELLES N°6 COMME INDIQUE SUR LA PHOTO A ;
4. METTRE LE COUVRE PLATINE N°10 SUR LA PLATINE MONOKEY N°9 ET VISSER LES VIS N°13 COMME INDIQUE SUR LA PHOTO B.

## D BAUANLEITUNG

1. POSITIONIEREN SIE DIE PLÄTTCHEN NR. 1, 2 UND 4 WIE IM BILD A BESCHRIEBEN;
2. POSITIONIEREN SIE DIE MOOSGUMMIS NR. 3, DIE DISTANZSTÜCKE NR. 8 UND DIE SCHEIBEN NR. 6 WIE IM BILD A BESCHRIEBEN;
3. POSITIONIEREN SIE DIE PLATTENABDECKUNG NR. 10 AUF DIE MONOKEY PLATTE NR. 9 UND ZIEHEN SIE DIE SCHRAUBEN NR. 13 WIE IM BILD B FEST.

## ES

## INSTRUCCIONES DE MONTAJE

1. POSICIONAR LAS PLETINAS N° 1, 2 Y 4 COMO INDICA LA FOTO A;
2. COLOCAR LA GOMA PROTECTORA N° 3, LOS DISTANCIADORES N° 8 Y LA PARRILLA MONOKEY
3. ATORNILLAR LOS TORNILLOS N° 5 CONTROLANDO EL CORRECTA POSICIÓN DE LAS PLAQUETAS N° 7 Y DE LAS ARANDELAS N° 6, COMO INDICA LA FOTO A
4. MONTAR EL CUBRE PARRILLA N° 10 SOBRE LA PARRILLA MONOKEY N° 9 Y ATORNILLAR LOS TORNILLOS N° 13 COMO INDICA LA FOTO B