

Gepäckbrücke
Alu-Rack
HONDA XL 700V Transalp

Artikel-Nr.:
650.952 01 01 schwarz/silber

Seitenkoffer
Topcases
Gepäckträger
Lock it System
Softbags
Aluminiumkoffer
Lederkoffer
Schutzbügel
Hauptständer
Chopper-Parts
Quad-Parts
Accessoires



Montage

Der Bausatz umfaßt die folgenden Teile:

Stück	Bestellnr.	Bezeichnung
1	799.901HB	Alu-Rack
1	799.902HB	TC-Bügel für Alu-Rack
1	799.903HB	Abdeckplatte für Rack
1	701.281HB	Adapterplatte
4	150.885	Inbusschrauben M6 x12
4	150.762	Inbusschrauben M6 x18
4	150.164	Viereck-Scheiben 20 x 20 x ø6,4
4	151.145	Senkinbusschrauben M8 x 30
4	150.803	Tensilockmuttern M8

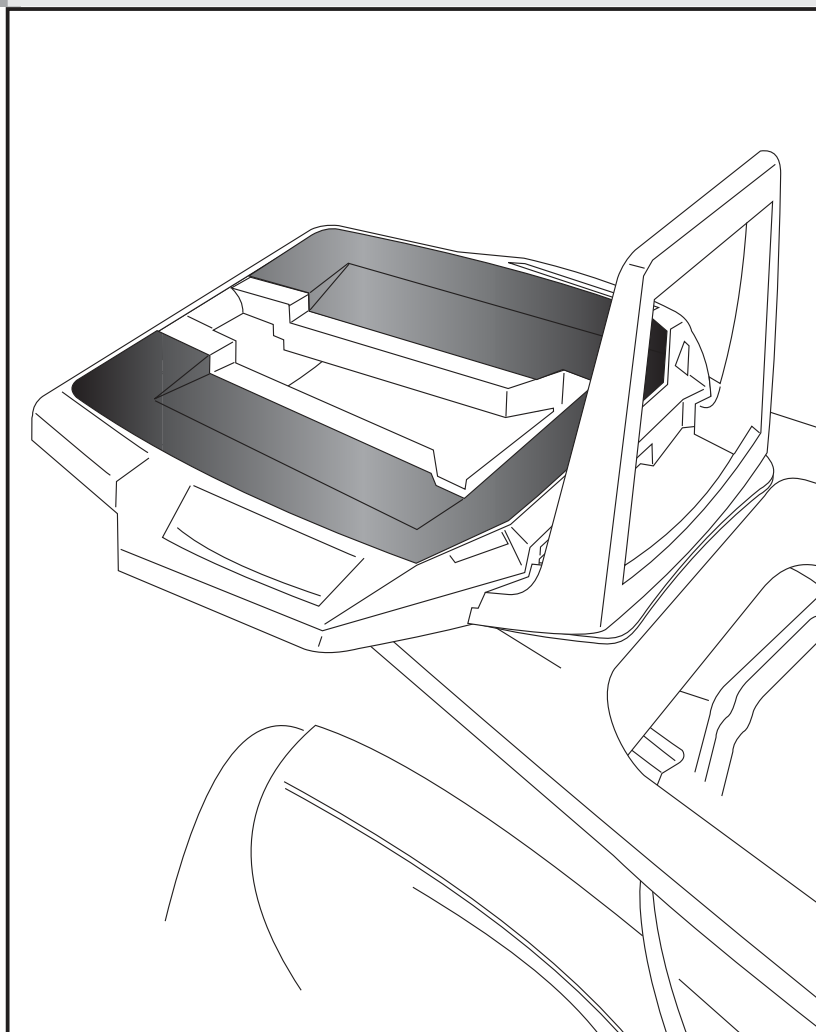

Anzugsmomente des Motorradherstellers beachten!
Nach der Montage alle Verschraubungen auf festen Sitz kontrollieren!
Bitte beachten Sie unsere beigefügten Serviceinformationen.

Als weiteres Zubehör lieferbar:

650.952 00 01	Kofferträger, Lock it System, abnehmbar
505.952 00 01	Hauptständer
502.114 00 01	Motorschutzbügel
700.952 00 01	Zusatzscheinwerfer Microflooder (nur in Verbindung mit Motorschutzbügel)



Hepco & Becker GmbH
An der Steinmauer 6

D-66955 Pirmasens

Tel.: 06331 - 1453 - 100
Fax: 06331 - 1453 - 120
eMail: vertrieb@hepco-becker.de
www.hepco-becker.de

Gepäckbrücke
Alu-Rack
HONDA XL 700V Transalp

Artikel-Nr.:
650.952 01 01 schwarz/silber

Seitenkoffer
Topcases
Gepäckträger
Lock it System
Softbags
Aluminiumkoffer
Lederkoffer
Schutzbügel
Hauptständer
Chopper-Parts
Quad-Parts
Accessoires



Montage

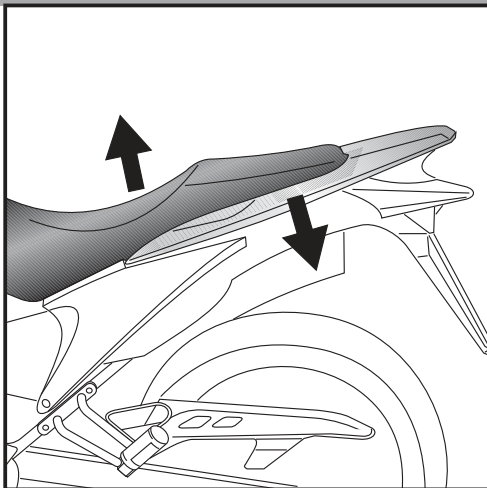

Vorbereitung:

Sitzbank und Originalgepäckträger demontieren.
Die Gummileisten am Originalgepäckträger abnehmen - diese entfallen.

Tipp:

Schrauben sie alle Teile an und lassen sie die zugänglichen Schrauben etwas locker. Nachdem alles montiert ist, werden alle Schrauben auf das entsprechende Anzugsmoment angezogen. Dadurch wird sichergestellt, dass das Produkt spannungsfrei angebaut ist. Damit ist eine lange Lebensdauer sichergestellt !

HINWEIS:

Die Montage der Adapterplatte erfolgt am abgenommenen Originalgepäckträger.

Befestigung der Adapterplatte in den freien Bohrungen der Brücke montieren. Hierbei die Senkinbusschrauben M8 x 30 mit Tensilockmuttern M8 verwenden.

Nach Montage der Adapterplatte den Originalgepäckträger wieder am Motorrad anbringen.

1

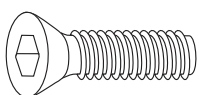
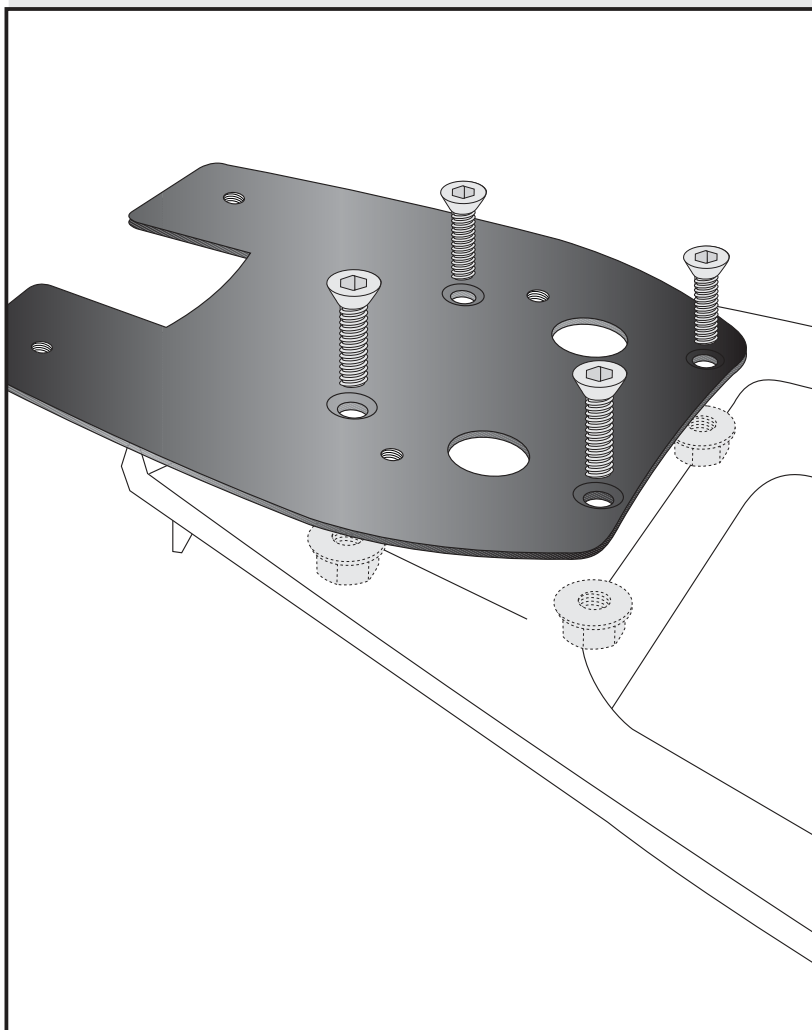

je 4x



Gepäckbrücke
Alu-Rack
HONDA XL 700V Transalp

Artikel-Nr.:
650.952 01 01 schwarz/silber

Seitenkoffer
Topcases
Gepäckträger
Lock it System
Softbags
Aluminiumkoffer
Lederkoffer
Schutzbügel
Hauptständer
Chopper-Parts
Quad-Parts
Accessoires



Montage

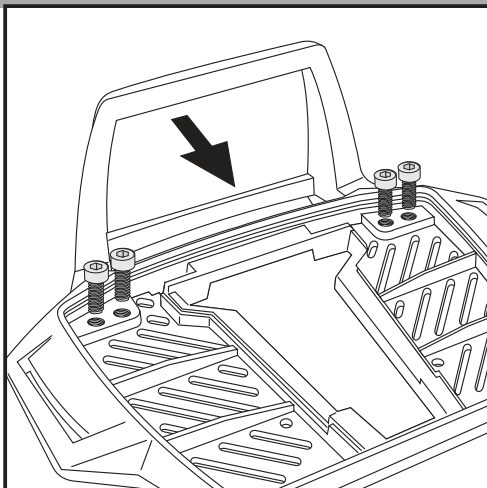

2

Vorbereitung des Alu-Racks:
Kunststoffblende vorsichtig abnehmen.
Den beiliegenden TC-Bügel mit den Inbusschrauben 6 x 12
hinten unter dem Alu-Rack verschrauben.

HINWEIS:
Der TC-Bügel ist nur bei Anbringung eines Hepco & Becker
Topcases erforderlich.

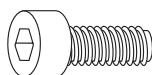

4x

Montage des Alu-Rack:

Das Alu-Rack wird mit den Inbusschrauben M6 x 18 und Viereckscheiben 20 x 20 x ø6,4 auf der Adapterplatte verschraubt.

Anschließend die Kunststoffabdeckung des Alu-Racks montieren.

3

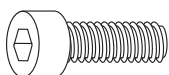
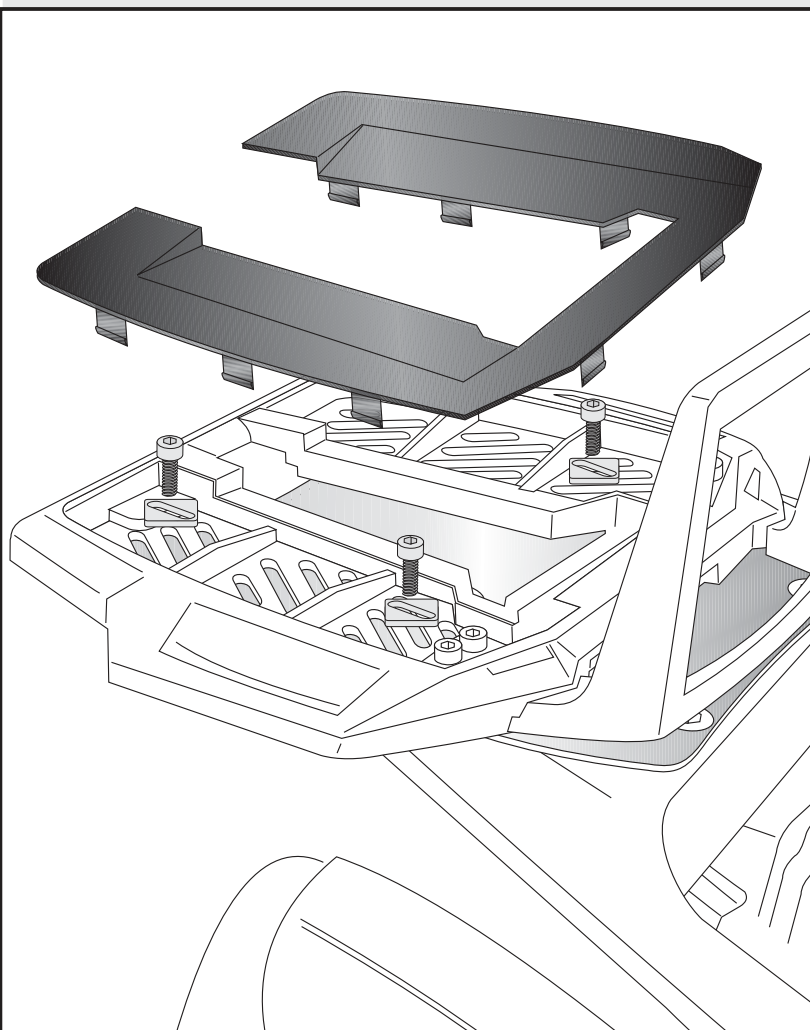

je 4x

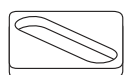

Rear aluminium rack
HONDA XL 700V Transalp

Item - No.:
650.952 01 01 black/silver

Assembling instructions

The kit includes the following parts:

Quant	item no.	description
1	799.901HB	alu-rack
1	799.902HB	bow for Alu-rack
1	799.903HB	plastic cover for rack
1	701.281HB	adapter plate
4	150.885	countersunk head
	151.145	allen screw M8 x30
4	150.885	allen screw M6 x12
4	150.762	allen screw M6 x18
4	150.164	special washer 20 x 20 x ø6,4
4	150.803	tensilock nut M8

Side cases
Top cases
luggage frames
Lock it system
Softbags
Aluminium luggage
Leather luggage
Protection bars
Center stands
Chopper parts
Quad parts
Accessories

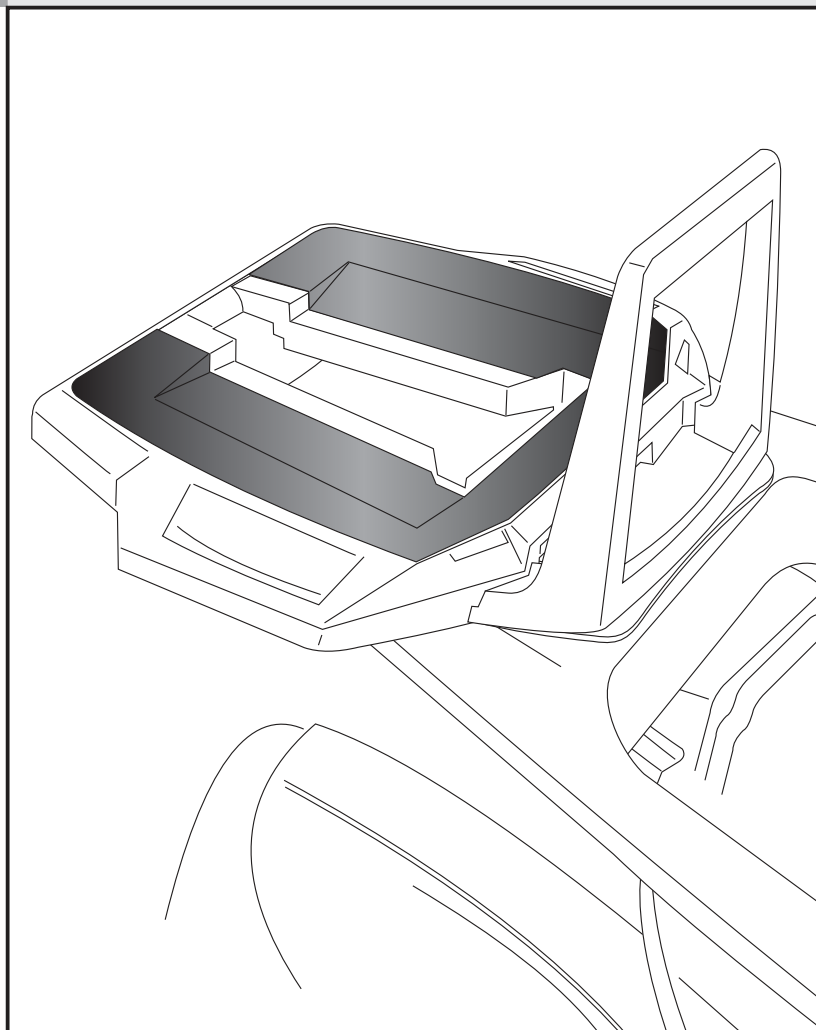

**Control all screw connections after the assembling for tightness!
Please notice our enclosed service information.**

Also available:

650.952 00 01	Side carrier, Lock it system (removable)
505.952 00 01	Centre stand
502.114 00 01	Engine guard
700.952 00 01	Light-set Microfloater (only in combination with engine guard)



Hepco & Becker GmbH
An der Steinmauer 6
D-66955 Pirmasens
Germany

Tel.: +49 6331 - 1453 - 100
Fax: +49 6331 - 1453 - 120
eMail: vertrieb@hepco-becker.de
www.hepco-becker.de

Rear aluminium rack
HONDA XL 700V Transalp

Item - No.:
650.952 01 01 black/silver

Assembling instructions

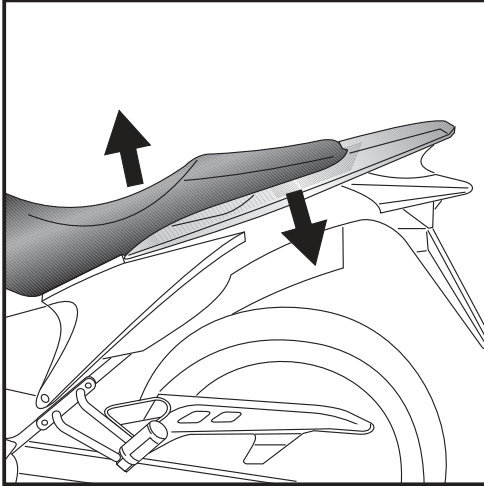

Side cases
Top cases
Luggage frames
Lock it system
Softbags
Aluminium luggage
Leather luggage
Protection bars
Center stands
Chopper parts
Quad parts
Accessories



Preparing:

Unmount seat and the original rear rack.

Dismantle rubber strings at the rear rack - they are obsolete.

Tip:

Fit all parts and screw on not too strong.

After mounting all parts, the screws should be tightened to the torque specified.

This guarantees, that the kit is mounted without tension.

NOTICE:

The fastening of the adapter plate will take place at the demounted original carrier.

Use countersunk head allen screw M8 x 30 with tensilock nuts M8.

After that, mount the original carrier again.

1

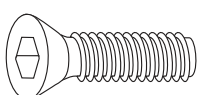
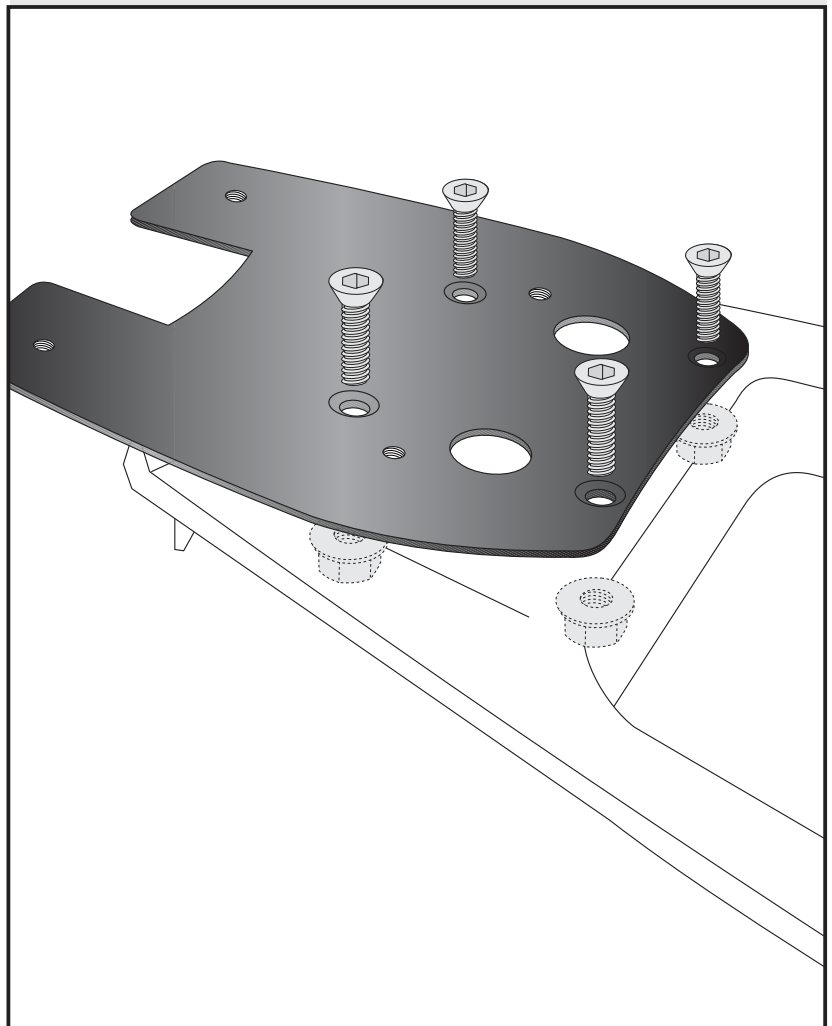

each
4x



Luggage ideas.

2

Rear aluminium rack
HONDA XL 700V Transalp

Item - No.:
650.952 01 01 black/silver

Assembling instructions

Side cases
Top cases
Luggage frames
Lock it system
Softbags
Aluminium luggage
Leather luggage
Protection bars
Center stands
Chopper parts
Quad parts
Accessories

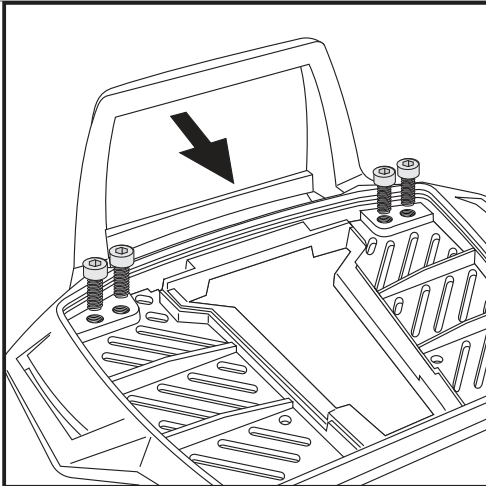

2

Fastening of the bow for the rack:
Dismantle the plastic cover of the alu-rack.
Fix the bow to the rack with allen screws
M6 x 12.

NOTICE:

The bow is only needed in use with a Hepco & Becker topcase.

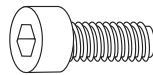

4x

Fastening of the alu-rack:
with allen screws M6x18 and
special washers 20 x 20 x ø6,4.

Mount the plastic cover again.

3

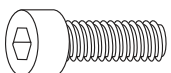
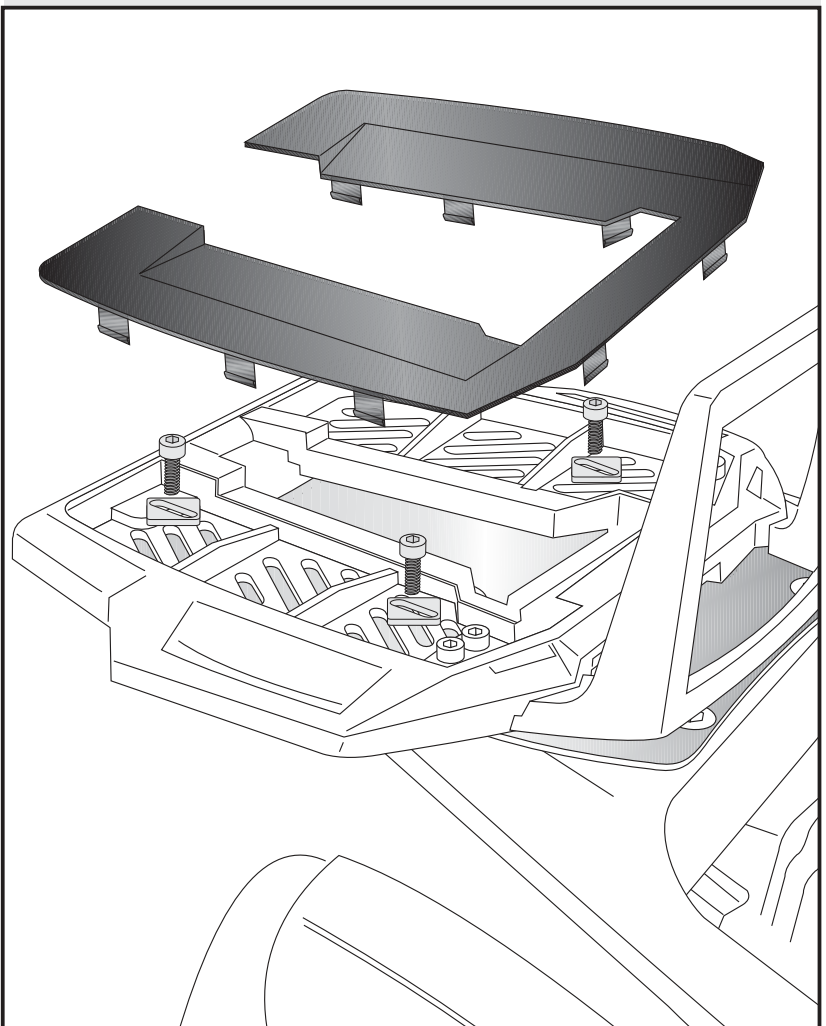

each
4x

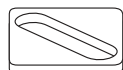

Luggage ideas.

3