

Gepäckbrücke Alurack

KAWASAKI ER-6n/f
ab Baujahr 2009

Artikel-Nr.:
650.2507 01 01 schwarz

Seitenkoffer
Topcases
Gepäckträger
Lock it System
Softbags
Aluminiumkoffer
Lederkoffer
Schutzbügel
Hauptständer
Chopper-Parts
Quad-Parts
Accessoires



Montage

Der Bausatz umfaßt die folgenden Teile:

Stück	Bestellnr.	Bezeichnung			
1	799.901HB	Alu-Rack	6	150.763	Inbusschrauben M6 x 20
1	799.902HB	TC-Bügel für Alu-Rack	8	150.799	selbstsichernde Muttern M6
1	799.903HB	Abdeckplatte für Rack	8	150.809	U-Scheiben ø6,4
1	702.271HB	Adapterbügel	4	150.810	U-Scheiben ø8,4
1	702.272HB	Rohradapter links	4	150.164	Viereck-Scheiben 20 x 20 x ø6,4
1	702.273HB	Rohradapter rechts	2	150.769	Inbusschrauben M6x50
1	702.273HB	Rohradapter rechts	4	150.794	Linienkopfschrauben M8x80
4	150.885	Inbusschrauben M6 x12	4	151.219	Aludistanzen ø21xø9x13mm



Anzugsmomente des Motorradherstellers beachten!

Nach der Montage alle Verschraubungen auf festen Sitz kontrollieren!

Bitte beachten Sie unsere beigegefügte Serviceinformationen.

Als weiteres Zubehör lieferbar:

Kofferträger, abnehmbar (Lock it System)
Motorschutzbügel schwarz

Artikel-Nr. 650.2507 00 01

Artikel-Nr. 501.2507 - nur passend für Modell ER-6n !



Hepco & Becker GmbH
An der Steinmauer 6

D-66955 Pirmasens

Tel.: 06331 - 1453 - 100

Fax: 06331 - 1453 - 120

eMail: vertrieb@hepco-becker.de

www.hepco-becker.de

Gepäckbrücke Alurack

KAWASAKI ER-6n/f
ab Baujahr 2009

Artikel-Nr.:
650.2507 01 01 schwarz

Seitenkoffer
Topcases
Gepäckträger
Lock it System
Softbags
Aluminiumkoffer
Lederkoffer
Schutzbügel
Hauptständer
Chopper-Parts
Quad-Parts
Accessoires



Montage

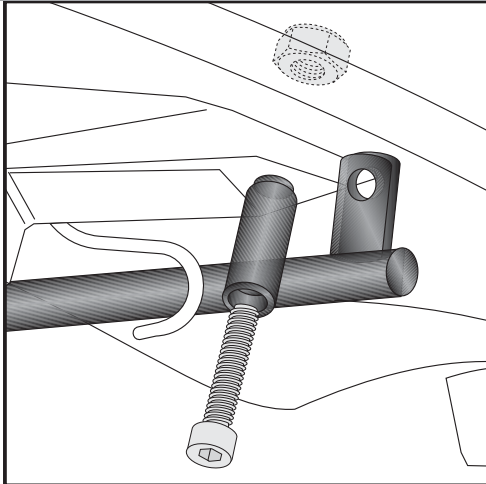

1

Vorbereitung:

Sitzbank demontieren.
Haltegriffe entfernen, sie werden wieder verbaut.
Blinker verbleiben in Originalposition.

Zuerst muss der Haltebügel unter dem Kotflügel montiert werden. Er wird zusammen mit der vorderen Kotflügelverschraubung mit Inbusschrauben M6 x 50 verschraubt. Auf das überstehende Gewinde die selbstsichernde Mutter M6 montieren.

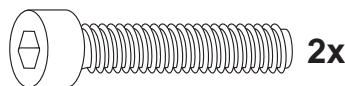

2x

2x

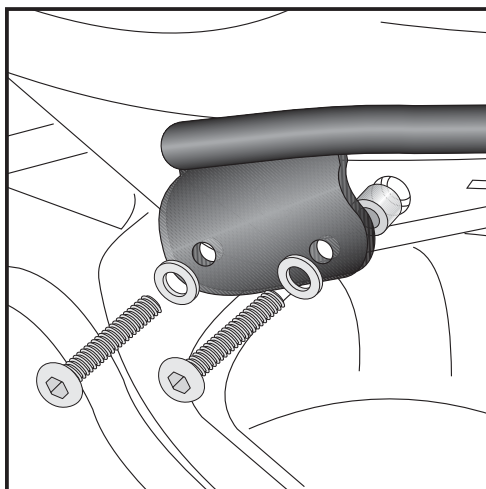

2

Befestigung der Adapterrohre links und rechts vorne:

Adapterrohre aussen über den Haltegriffen mit den Linsenkopfschrauben M8x80, sowie U-Scheiben $\varnothing 8,4$ verschrauben. Zwischen Adapter und Haltegriff die Aludistanzen $\varnothing 21 \times \varnothing 9 \times 13$ mm fügen. Noch nicht ganz festziehen.

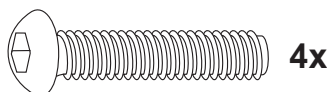

4x

4x

4x

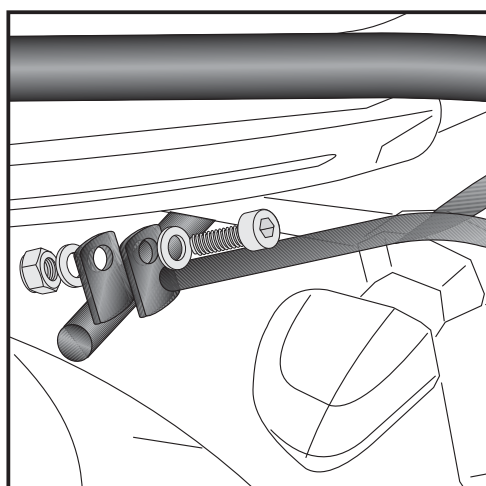

3

Befestigung der Adapterrohre links und rechts hinten:

Der Ausleger der Adapterrohre wird an dem zuvor montierten Adapterbügel mit den Inbusschrauben M6x20 sowie U-Scheiben $\varnothing 6,4$, und SS-Muttern M6 verschraubt. Noch nicht ganz festziehen.

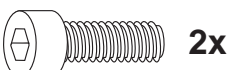

2x

4x



2x



Gepäckbrücke Alurack

KAWASAKI ER-6n/f
ab Baujahr 2009

Artikel-Nr.:
650.2507 01 01 schwarz

Seitenkoffer
Topcases
Gepäckträger
Lock it System
Softbags
Aluminiumkoffer
Lederkoffer
Schutzbügel
Hauptständer
Chopper-Parts
Quad-Parts
Accessoires



Montage

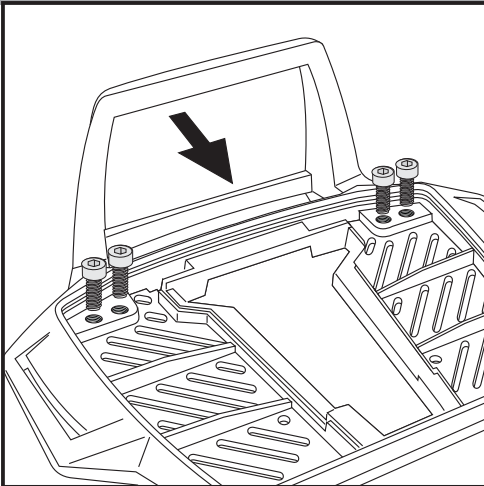

4

Vorbereitung des Alu-Racks:

Den beiliegenden TC-Bügel mit den Inbusschrauben 6 x 12 hinten unter dem Alu-Rack verschrauben.

HINWEIS:

Der TC-Bügel ist nur bei Anbringung eines Hepco & Becker Topcases erforderlich.

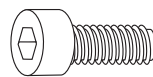

4x

Montage des Alu-Rack:

Das Alu-Rack wird mit den Inbusschrauben M6 x 20, Viereck-Scheiben 20 x 20 x ø6,4, U-Scheiben ø6,4 und selbstsichernden Muttern M6 an den deckungsgleich vorhandenen Bohrungen der Rohradapter verschraubt.

Das Alurack so ausrichten, dass sich das Halteschloss des Topcases leicht öffnen und schliessen lässt.

Alle Schrauben festziehen.

Anschließend die Kunststoffabdeckung des Alu-Racks montieren.

5

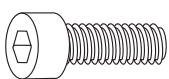
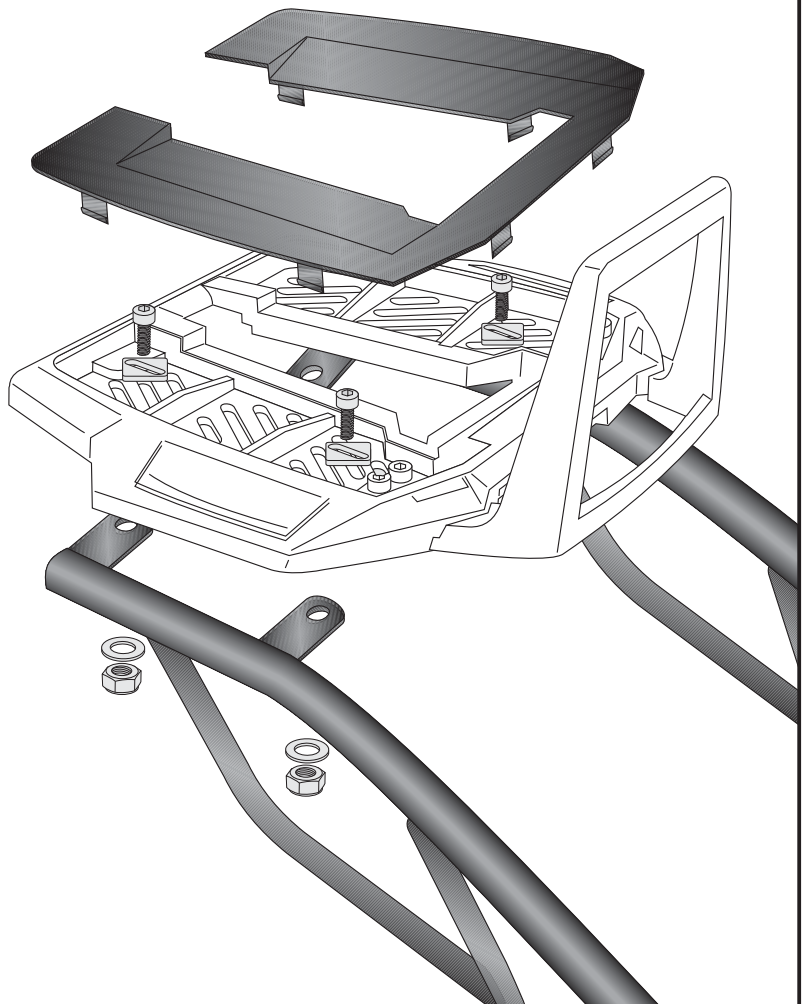

je 4x

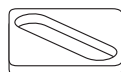

Rear carrier
Aluminium rack

KAWASAKI ER-6n/f
from date of manufacture 2009

Item - No.:
650.2507 01 01 black

Assembling instructions

Side cases

Top cases

luggage frames

Lock it system

Softbags

Aluminium luggage

Leather luggage

Protection bars

Center stands

Chopper parts

Quad parts

Accessories



The kit includes the following parts:

Quant	item no.	description			
1	799.901HB	alu-rack	6	150.763	allen screw M6 x 20
1	799.902HB	bow for Alu-rack	8	150.799	self-lock nut M6
1	799.903HB	plastic cover for rack	8	150.809	washer ø6,4
1	702.271HB	adapter bow	4	150.810	washer ø8,4
1	702.272HB	adapter left	4	150.164	special washer 20 x 20 x ø6,4
1	702.273HB	adapter right	2	150.769	allen screw M6x50
1	150.885	allen screw M6 x12	4	150.794	filister head screw M8x80
4			4	151.219	alu spacer ø21xø9x13mm



Control all screw connections after the assembling for tightness!
Please notice our enclosed service information.

Also available:

Side carrier, removable (Lock it System)
Engine guard, black

Item-no. 650.2507 00 01
Item-no. 501.2507 - only for model ER-6n !



Hepco & Becker GmbH
An der Steinmauer 6
D-66955 Pirmasens
Germany

Tel.: +49 6331 - 1453 - 100
Fax: +49 6331 - 1453 - 120
eMail: vertrieb@hepco-becker.de
www.hepco-becker.de

Rear carrier
Aluminium rack

KAWASAKI ER-6n/f
from date of manufacture 2009

Item - No.:
650.2507 01 01 black

Side cases
Top cases
luggage frames
Lock it system
Softbags
Aluminium luggage
Leather luggage
Protection bars
Center stands
Chopper parts
Quad parts
Accessories



Assembling instructions

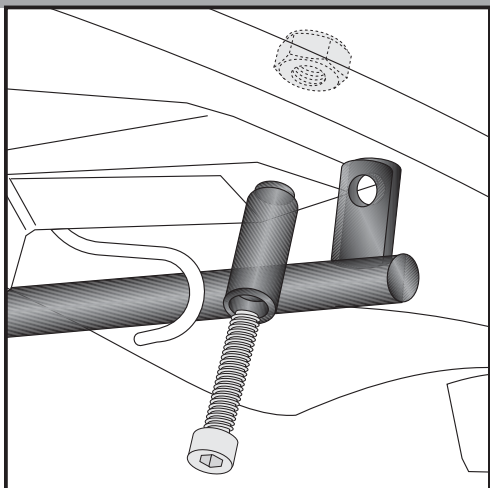

1

Preparing:
Dismantle seat.
Dismantle handle bars.
Blinker remains in original position.

First step is to mount the adapter bow under the fender together with the fender suspension. Use allen screw M6 x 50, self-lock nut M6.

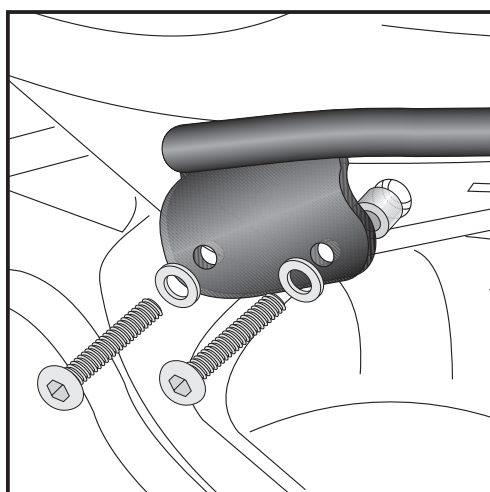
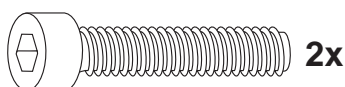

2

Fastening of the adapters left and right front:
Fix the adapters at the handle bars with filister head screw M8x80 and washers $\varnothing 8,4$.
Sandwich alu spacer $\varnothing 21 \times \varnothing 9 \times 13 \text{mm}$ between adapter and handle bars.

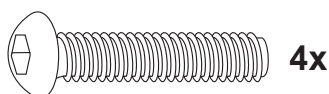

4x

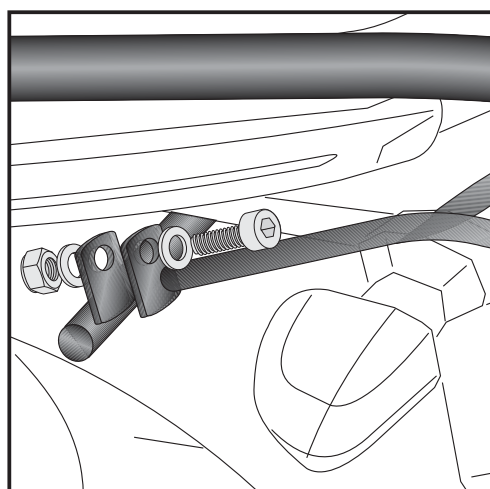

3

Fastening of the adapters left and right back:
Fix the adapters to the adapter bow with allen screw M6x20, washers $\varnothing 6,4$ and self-lock nuts M6.

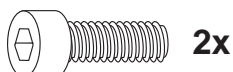

Rear carrier
Aluminium rack

KAWASAKI ER-6n/f
from date of manufacture 2009

Item - No.:
650.2507 01 01 black

Side cases
Top cases
luggage frames
Lock it system
Softbags
Aluminium luggage
Leather luggage
Protection bars
Center stands
Chopper parts
Quad parts
Accessories



Assembling instructions

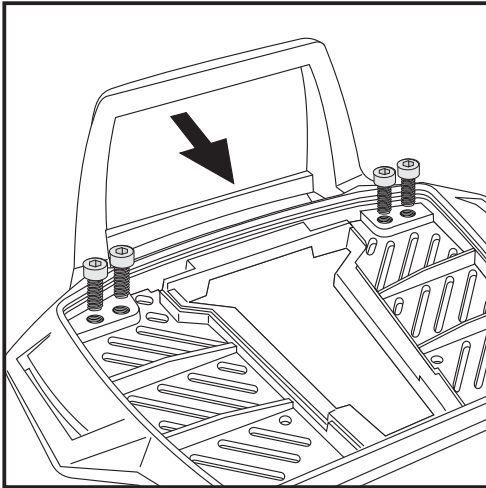

4

Fastening of the bow for the rack:

Fix the bow to the rack with allen screws
M6 x 12.

NOTICE:
The bow is only needed in use with a Hepco & Becker topcase.

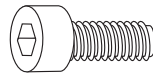

4x

Fastening of the alu-rack:
with allen screws M6 x 20, special washer
20 x 20 x ø6,4, washers ø6,4 and self-
lock nuts M6.

Chosse position of the rack so, that the
fixing lock of the topcase (if used) can
easily be locked/unlocked.

Mount the plastic cover.

5

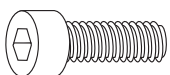
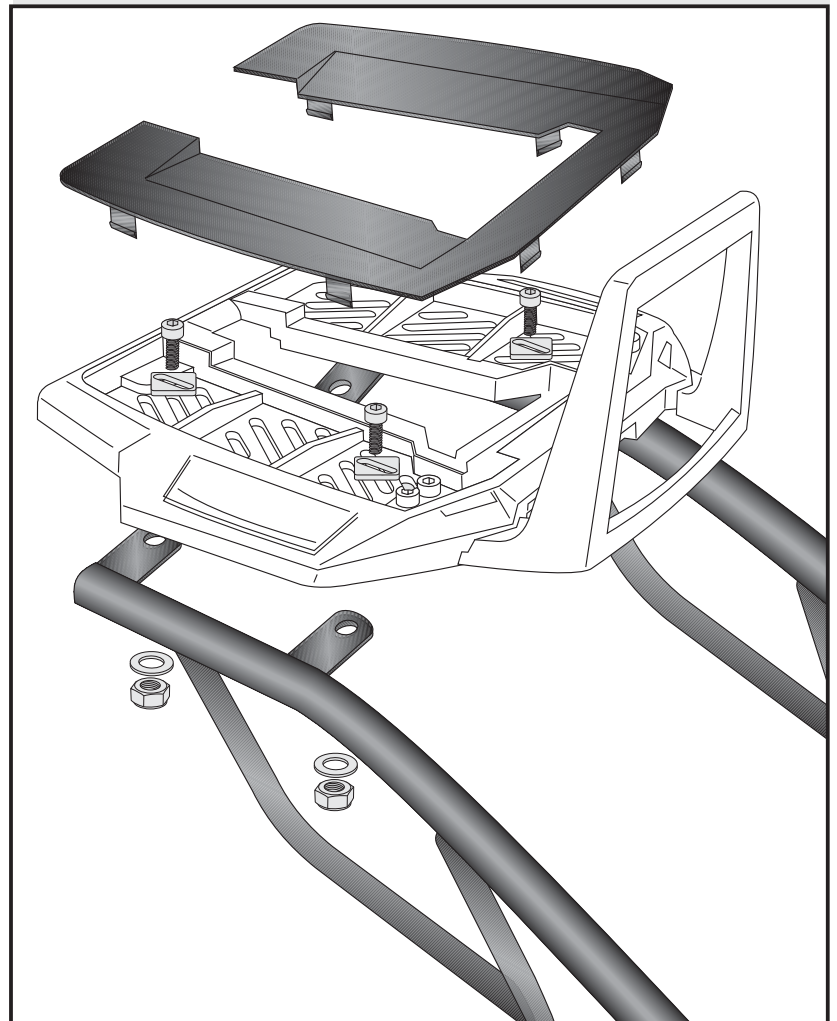

each
4x

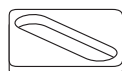

Luggage ideas.

3