



C-Bow

DUCATI Monster 821

Artikel-Nr.: 630.7527 schwarz

DUCATI Monster 821

Artikel-Nr.: 4009.009.131 schwarz

Montage

Der Bausatz umfaßt die folgenden Teile:

Stück	Bestellnr.	Bezeichnung
2	700007063	C-Bow schwarz
1	700008435	C-Bow Halteadapter links
1	700008436	C-Bow Halteadapter rechts
2	151.006	Linsenkopfschrauben M8x80
2	150.725	Linsenkopfschrauben M8x90
8	150.809	U-Scheiben Ø6,4
4	150.810	U-Scheiben Ø8,4
8	150.916	Sechskantschrauben M6x18
8	150.832	Sechskantschrauben M6x35
4	151.443	Aludistanz abgesetzt Ø20xØ9x9,5/3 mm
4	151.442	Stahldistanzen Ø12xØ9x12mm
8	151.445	Kunststoffdistanzen Ø16xØ7x16mm
4	150.825	Aludistanz Ø18xØ9x20mm schwarz

Montagehinweis:

Die Voraussetzung für die Montage ist natürlich eine gewisse technische Erfahrung. Wenn Sie sich nicht sicher sind, wie man eine bestimmte Arbeit ausführt, sollten Sie diese Ihrer Fachwerkstatt überlassen.

Ziehen sie alle zugänglichen Schrauben zuerst nur locker an. Nachdem alles montiert ist, werden die Schrauben dann auf das entsprechende Anzugsmoment festgezogen. Dadurch wird sichergestellt, dass das Produkt spannungsfrei angebaut ist.

Tip: Am besten zu zweit arbeiten.



Anzugsmomente des Motorradherstellers beachten!
Nach der Montage alle Verschraubungen auf festen Sitz kontrollieren!
Bitte beachten Sie unsere beigefügten Serviceinformationen.

Weiteres Zubehör: Minirack 660.7527 von Hepco & Becker



Hepco & Becker GmbH
An der Steinmauer 6
D-66955 Pirmasens
Tel.: 06331 - 1453 - 100
Fax: 06331 - 1453 - 120
eMail: vertrieb@hepco-becker.de
www.hepco-becker.de



Krauser GmbH
An der Steinmauer 6
D-66955 Pirmasens
Tel.: 06331 - 1453 - 250
Fax: 06331 - 1453 - 260
eMail: vertrieb@krauser.de
www.krauser.de



C-Bow

DUCATI Monster 821

Artikel-Nr.: 630.7527 schwarz

DUCATI Monster 821

Artikel-Nr.: 4009.009.131 schwarz

Montage

Vorbereitung:

Den Heckausleger und Handgriffe am Heck demontieren. Die Stehbolzen mit Sechskant demontieren.
In die Gummitüllen des Heckauslegers die Stahldistanzen $\varnothing 12 \times 9 \times 12 \text{ mm}$ eindrücken. Die Original Befestigungsschrauben entfallen.

4x



1

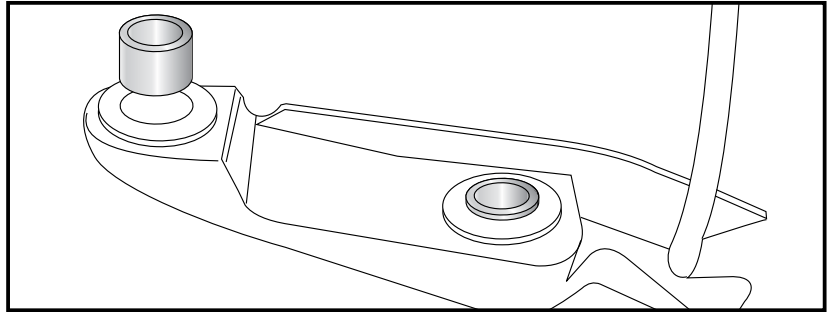

Die abgesetzten Aludistanzen $\varnothing 20 \times 9 \times 9,5/3 \text{ mm}$ auflegen.

4x



2

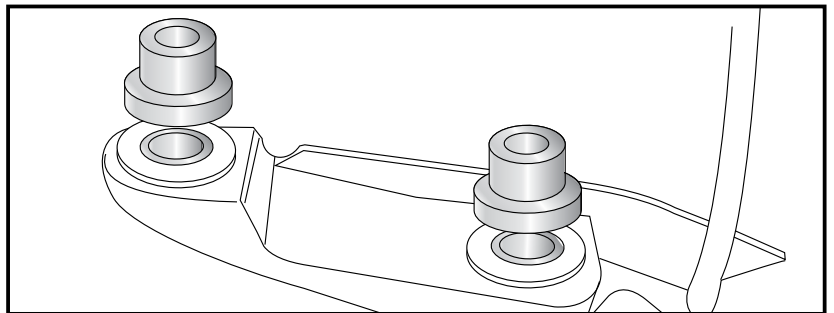

Montage der Halteadapter links + rechts:

Zusammen mit dem Heckausleger und den Handgriffen.

VORNE ①

mit den Linsenkopfschrauben M8x80 sowie U-Scheiben $\varnothing 8,4$. Zwischen Rohradapter und Haltegriffen die Aludistanzen $\varnothing 18 \times 9 \times 20 \text{ mm}$ fügen.

HINTEN ②

mit den Linsenkopfschrauben M8x90 sowie U-Scheiben $\varnothing 8,4$. Zwischen Rohradapter und Haltegriffen die Aludistanzen $\varnothing 18 \times 9 \times 20 \text{ mm}$ fügen.

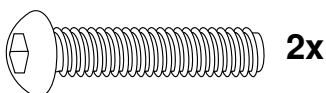

2x

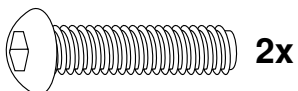

2x



4x

4x

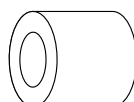

3

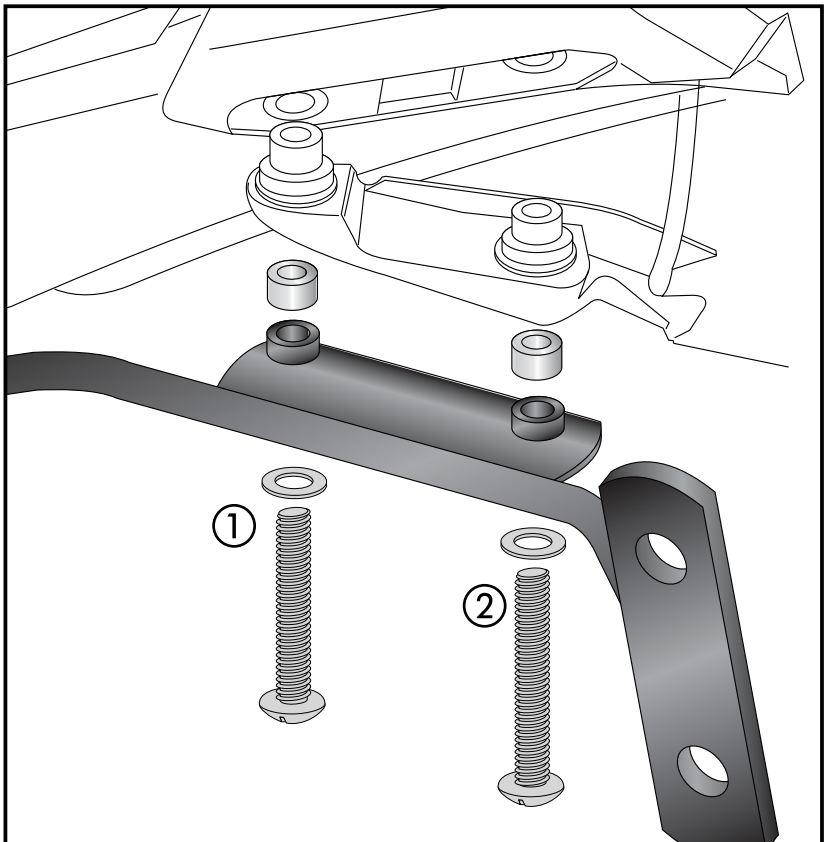



C-Bow

DUCATI Monster 821

Artikel-Nr.: 630.7527 schwarz

DUCATI Monster 821

Artikel-Nr.: 4009.009.131 schwarz

Montage

4 Montage der C-Bow links + rechts:
Dazu die Sechskantschrauben M6x18
und die U-Scheiben Ø6,4 verwenden.

Alle Teile korrekt ausrichten und die
Verschraubungen festziehen.

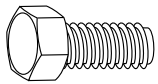

8x

8x

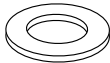

4

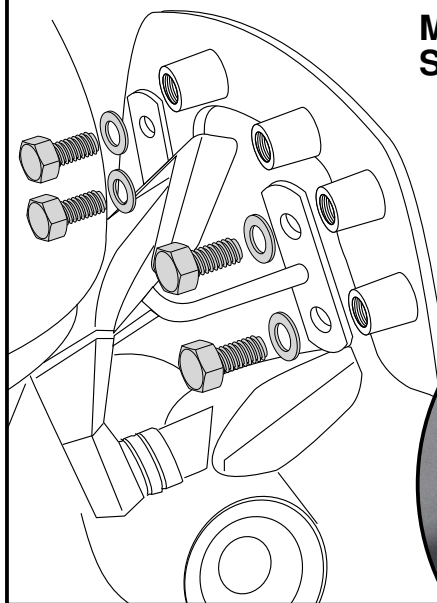

**Montage ohne
Sozius-Sitz Abdeckung**



4 Montage der C-Bow links + rechts:
Dazu die Sechskantschrauben M6x35
und die U-Scheiben Ø6,4 verwenden.
Kunststoffdistanzen Ø16xØ7x16mm
zwischen C-Bow und Halteadapter fügen.

Alle Teile korrekt ausrichten und die
Verschraubungen festziehen.

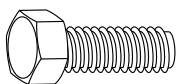

8x

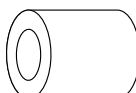

8x

8x



4

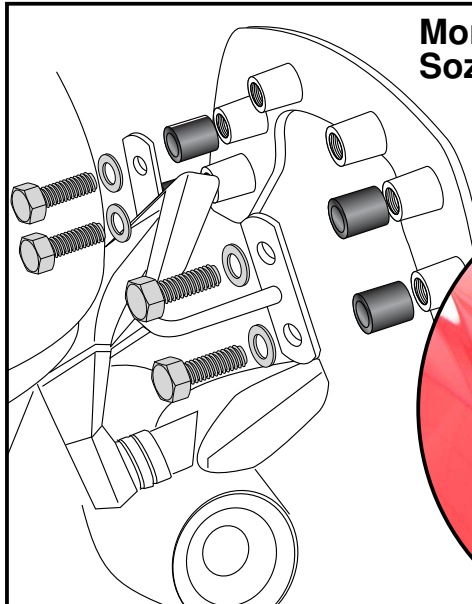

**Montage mit
Sozius-Sitz Abdeckung**





C-Bow

DUCATI Monster 821

Item - No.: 630.7527 black

DUCATI Monster 821

Item - No.: 4009.009.131 black

Assembling instructions

The kit includes the following parts:

Quant	item no.	description
2	700007063	C-Bow black
1	700008435	C-Bow adapter left
1	700008436	C-Bow adapter right
2	151.006	filister head screw M8x80
2	150.725	filister head screw M8x90
8	150.809	washer Ø6,4
4	150.810	washer Ø8,4
8	150.916	hexagon bolt M6x18
8	150.832	hexagon bolt M6x35
4	151.443	alu spacer, reduced Ø20xØ9x9,5/3 mm
4	151.442	steel spacer Ø12xØ9x12mm
8	151.445	plastic spacer Ø16xØ7x16mm
4	150.825	alu spacer Ø18xØ9x20mm black

Installation note:

Of course, the assembly requires a certain technical experience. If you are not sure how to execute a determined action, you should ask your local distributor to do it.

First, tighten all screws only loosely. After mounting all parts, the screws should be tightened to the torque specified. This guarantees, that the product is mounted without tension.

Tip: A second person is useful for the assembly.



Control all screw connections after the assembling for tightness!
Please notice our enclosed service information.

Also available: Mirirack 660.7525 from Hepco & Becker



Hepco & Becker GmbH
An der Steinmauer 6
D-66955 Pirmasens
Tel.: 0049 6331 - 1453 - 100
Fax: 0049 6331 - 1453 - 120
eMail: vertrieb@hepco-becker.de
www.hepco-becker.de



Krauser GmbH
An der Steinmauer 6
D-66955 Pirmasens
Tel.: 0049 6331 - 1453 - 250
Fax: 0049 6331 - 1453 - 260
eMail: vertrieb@krauser.de
www.krauser.de



C-Bow

DUCATI Monster 821

Item - No.: 630.7527 black

DUCATI Monster 821

Item - No.: 4009.009.131 black

Assembling instructions

Preparing:

Dismantle number plate holder.
Dismantle handle bars.
Stick steel spacers $\text{Ø}12 \times \text{Ø}9 \times 12 \text{mm}$ into the borings in the rubber grommets.
Original screws are obsolete.

4x



1

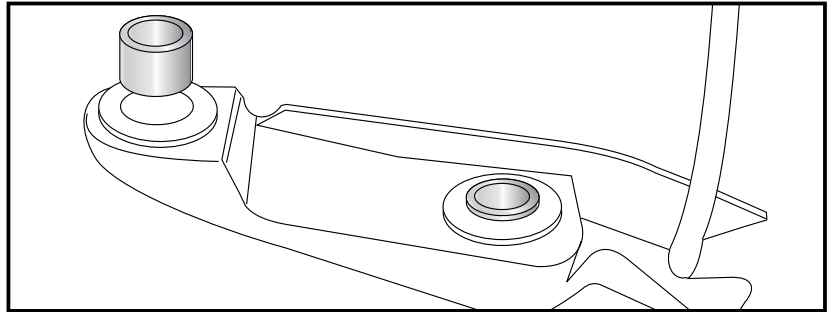

Place the partially reduced small alu spacer $\text{Ø}20 \times \text{Ø}9 \times 9,5/3 \text{mm}$ to the holes.

2x



2

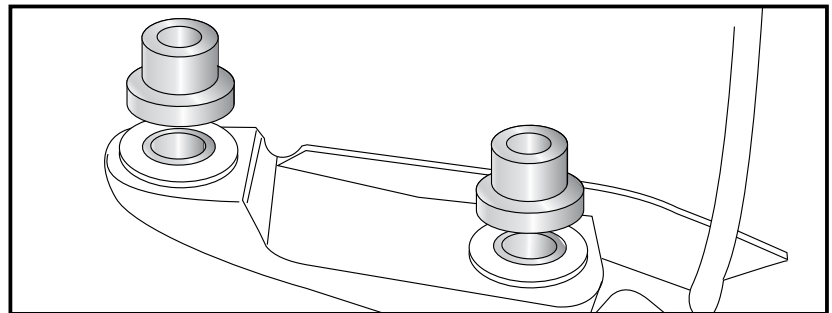

Fastening of the adapters left+right:
together with the handle bars and the
number plate holder.

FRONT ①

with filister head screws M8x80
with washers $\text{Ø}8,4$. Add spacers
 $\text{Ø}18 \times \text{Ø}9 \times 20 \text{mm}$ between tube adapters
and handle bars.

REAR ②

with filister head screws M8x90
with washers $\text{Ø}8,4$. Add spacers
 $\text{Ø}18 \times \text{Ø}9 \times 20 \text{mm}$ between tube adapters
and handle bars.

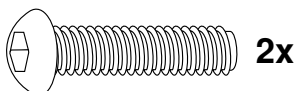
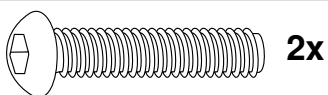

3

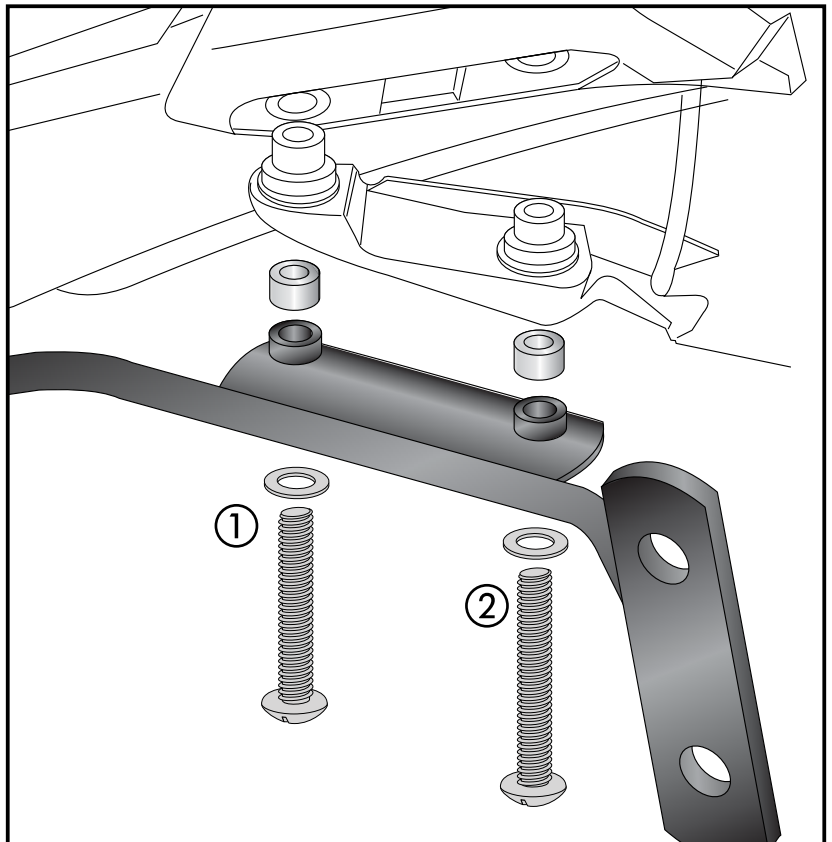



C-Bow

DUCATI Monster 821

Item - No.: 630.7527 black

DUCATI Monster 821

Item - No.: 4009.009.131 black

Assembling instructions

Fastening of the C-Bow:
with hexagon bolts M6 x 18 and washers $\varnothing 6,4$.

After mounting all parts, the screws should be tightened to the torque specified.

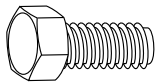

8x

8x

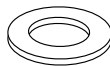

4

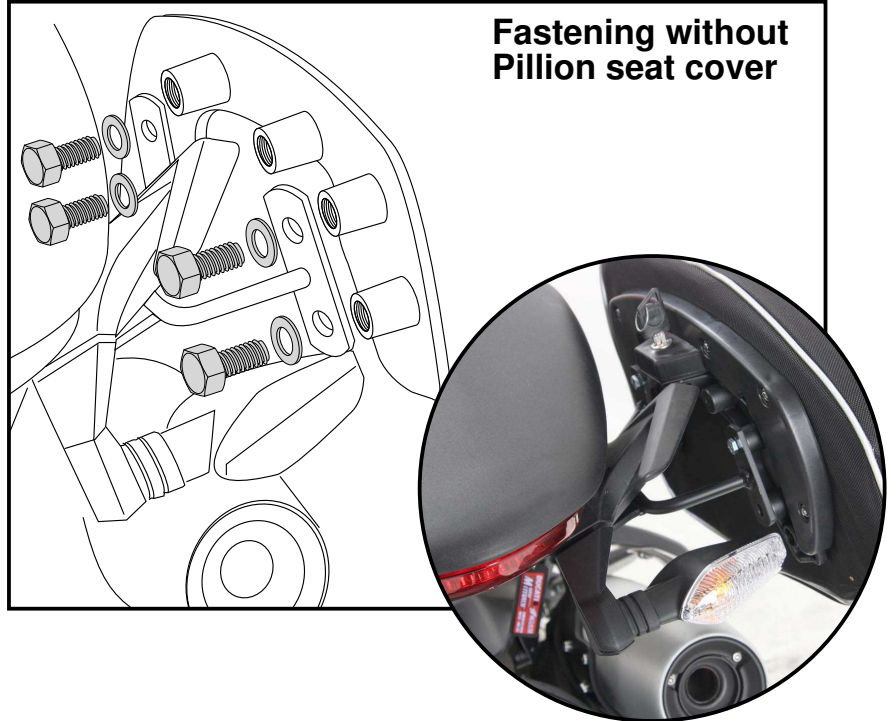

Fastening without Pillion seat cover

Fastening of the C-Bow:
with hexagon bolts M6 x 35 and washers $\varnothing 6,4$.

Add plastic spacer $\varnothing 16 \times \varnothing 7 \times 16 \text{mm}$ between C-Bow and adapter.

After mounting all parts, the screws should be tightened to the torque specified.

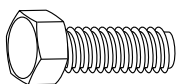

8x

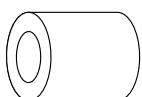

8x

8x



4

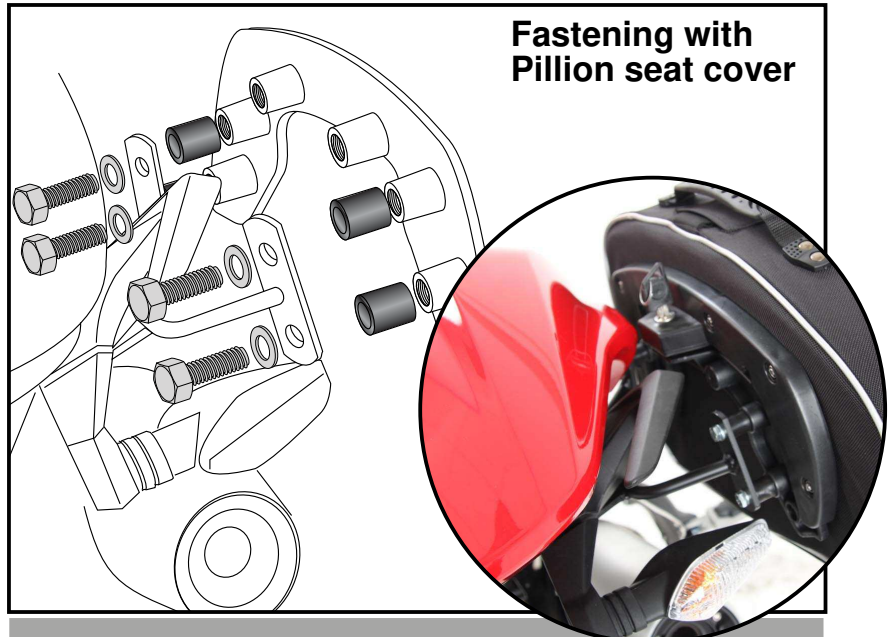

Fastening with Pillion seat cover