

C-Bow



YAMAHA MT - 07

Art.-Nr.: 630.4537 anthrazit

YAMAHA MT - 07

Art.-Nr.: 4005.048.131 anthrazit

Montage

Der Bausatz umfaßt die folgenden Teile:

Stück	Bestellnr.	Bezeichnung
2	700007063	C-Bow schwarz
1	700008582	C-Bow Adapter vorne links
1	700008583	C-Bow Adapter vorne rechts
1	700008584	C-Bow Adapter hinten links
1	700008587	C-Bow Adapter hinten rechts
2	700008586	Haltetasche vorne
6	150.784	Inbusschrauben M8x30
2	150.769	Inbusschrauben M6x50

Stück	Bestellnr.	Bezeichnung
8	150.916	Sechskantschrauben M6x18
8	150.809	U-Scheibe Ø6,4
6	150.810	U-Scheibe Ø8,4
2	150.889	Aludistanzen Ø15xØ9x25mm

Die hinteren Blinker verbleiben in der Originalposition.



Der C-Bow kann auch in Verbindung mit dem Yamaha Heckumbau lang und kurz montiert werden.

Als weiteres Zubehör lieferbar:
Alurack (mit C-Bow kombinierbar)
Lock it Kofferträger (abnehmbar)
Motorschutzbügel
Fußrasten Tieferlegung

Anzugsmomente des Motorradherstellers beachten!
Nach der Montage alle Verschraubungen auf festen Sitz kontrollieren!
Bitte beachten Sie unsere beigefügten Serviceinformationen.



Hepco & Becker GmbH
An der Steinmauer 6
D-66955 Pirmasens
Tel.: 0049 6331 - 1453 - 100
www.hepco-becker.de



Krauser GmbH
An der Steinmauer 6
D-66955 Pirmasens
Tel.: 0049 6331 - 1453 - 250
www.krauser.de



YAMAHA MT - 07

Art.-Nr.: 630.4537 anthrazit

YAMAHA MT - 07

Art.-Nr.: 4005.048.131 anthrazit

Montage

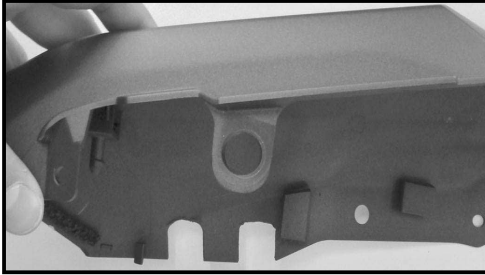

Vorbereitende Arbeiten:

Windabweiser am Heckausleger demontieren - dieser entfällt.

Heckausleger demontieren.

Die Heckverkleidung rechts und links muss im Bereich des Heckauslegers ausgespart werden - siehe Bild und Schablone.

Montage der Haltetaschen

vorne links und rechts:

Die Halteadapter werden hinter den den Soziusfußrasten am Rahmen verschraubt. Die Verschraubung erfolgt mit den Inbusschrauben M8 x 30 und U – Scheiben Ø8,4. Die Originalschrauben entfallen.

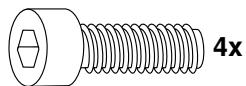

4x



4x

1

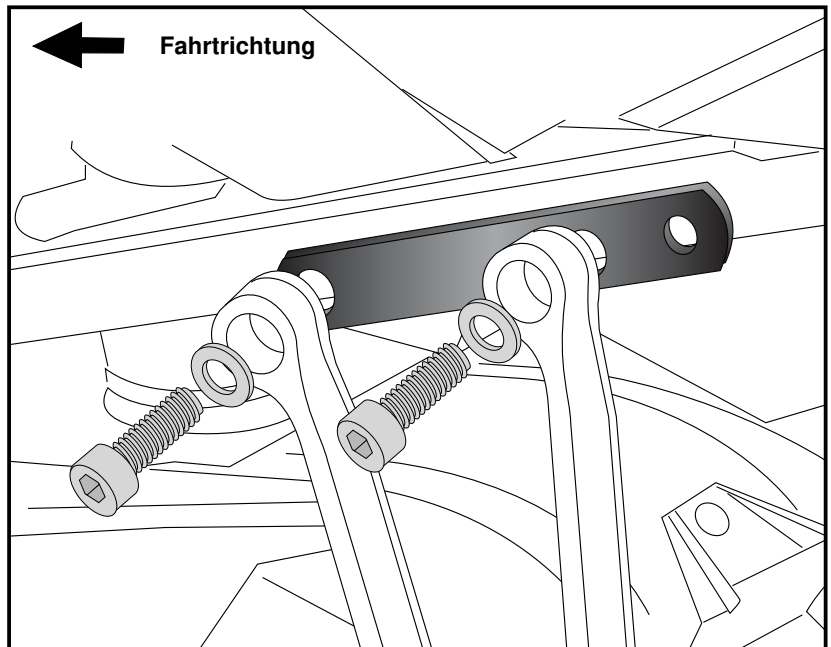

Montage der C-Bow Adapter

vorne links und rechts:

Die C-Bow Adapter werden an der freien Bohrung am Haltetaschen verschraubt. Die Verschraubung erfolgt mit den Inbusschrauben M8 x 30 und U – Scheiben Ø8,4.

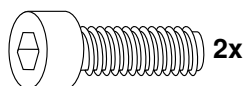

2x



2x

2

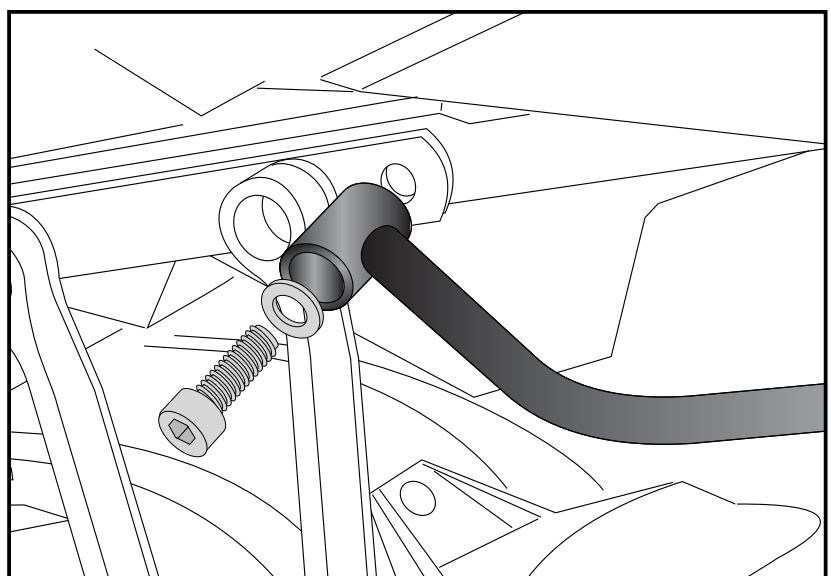



YAMAHA MT - 07

Art.-Nr.: 630.4537 anthrazit

YAMAHA MT - 07

Art.-Nr.: 4005.048.131 anthrazit

Montage

Montage der hinteren Halteadapter:

Die hinteren Halteadapter werden zusammen mit Heckausleger an das Rahmenheck montiert.

VORNE ①

mit den Originalschrauben.

HINTEN ②

mit den Inbusschrauben M6 x 50mm.

Zwischen Adapter und Heckausleger wird die Aludistanz $\varnothing 15 \times \varnothing 9 \times 25\text{mm}$ eingefügt.

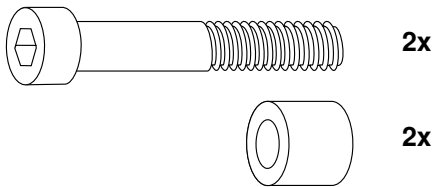

3

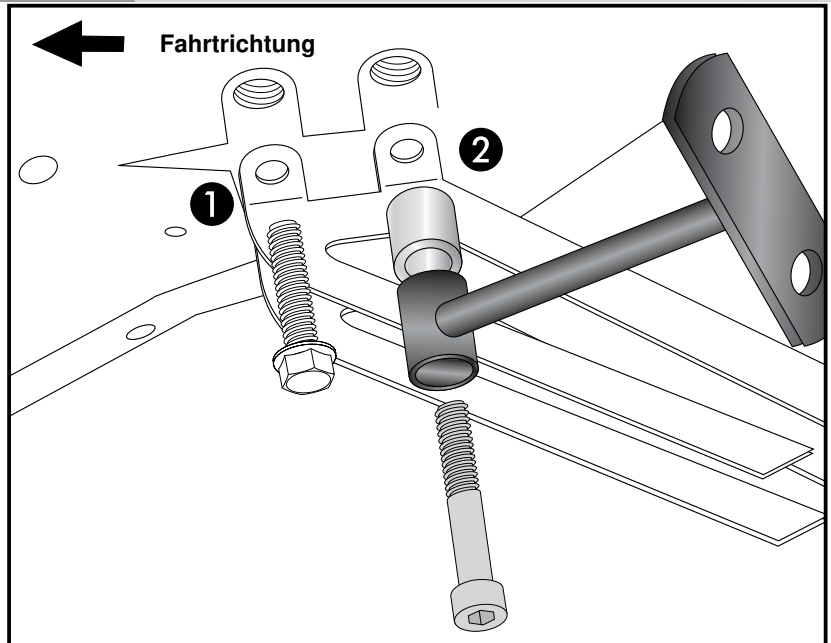

Montage der C-Bow links + rechts:

Dazu die Sechskantschrauben M6x18 und die U-Scheiben $\varnothing 6,4$ verwenden.

Alle Teile korrekt ausrichten und die Verschraubungen festziehen.



4

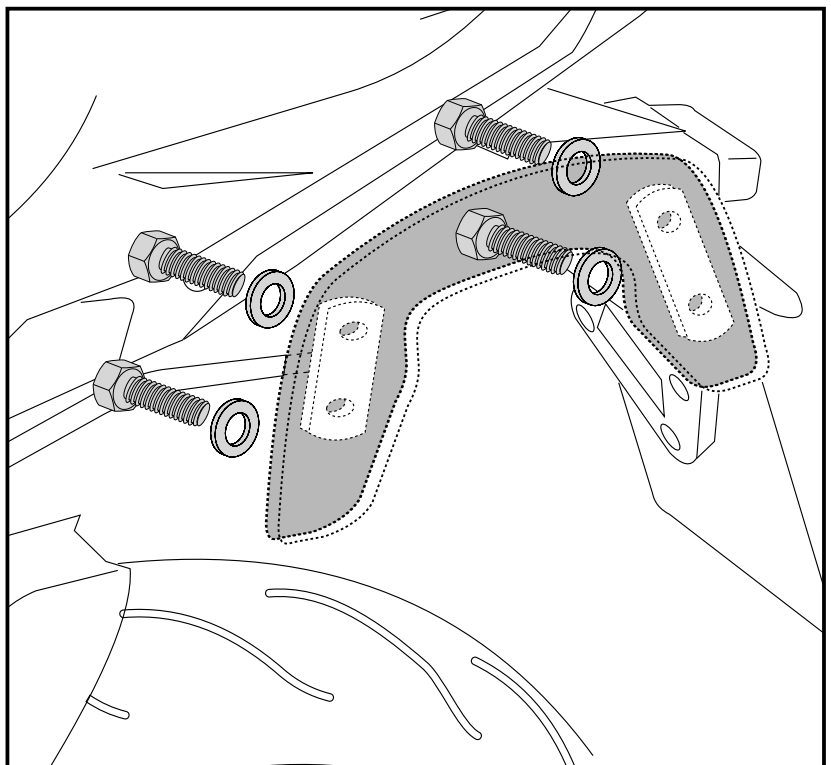

C-Bow

YAMAHA MT - 07

Item.-No.:
630.4537 anthracite



YAMAHA MT - 07

Item.-No.:
4005.048.131 anthracite

Assembling instructions

The kit includes the following parts:

Quant	item no.	description
2	700007063	C-Bow schwarz
1	700008582	C-Bow adapter front left
1	700008583	C-Bow adapter front right
1	700008584	C-Bow adapter rear left
1	700008587	C-Bow adapter rear right
2	700008586	holding adapter front
6	150.784	allen screws M8x30
2	150.769	allen screws M6x50

Quant	item no.	description
8	150.916	hexagon bolt M6x18
8	150.809	washer Ø6,4
6	150.810	washer Ø8,4
2	150.889	alu spacer Ø15xØ9x25mm

The rear blinkers remain in their original position.



The C-bow can also be fitted in connection with the OEM licence plate holder (long and short version).

Also available:
Rear rack, combinable with C-Bow
Lock it side carrier (removable)
Engine guard
Footrest lowering set

Control all screw connections after the assembling for tightness!
Please notice our enclosed service information.



Hepco & Becker GmbH
An der Steinmauer 6
D-66955 Pirmasens
Tel.: 0049 6331 - 1453 - 100
www.hepco-becker.de



Krauser GmbH
An der Steinmauer 6
D-66955 Pirmasens
Tel.: 0049 6331 - 1453 - 250
www.krauser.de

C-Bow

YAMAHA MT - 07

Item.-No.:
630.4537 anthracite



YAMAHA MT - 07

Item.-No.:
4005.048.131 anthracite

Assembling instructions

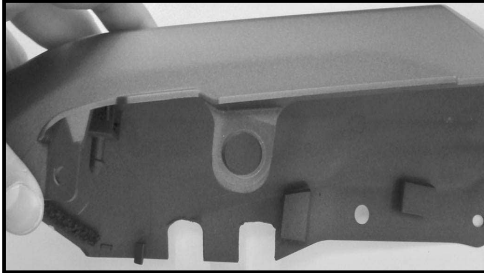

Preparing:

Dismantle wind deflector - this is obsolete.

Dismantle fender holder.

The rear panel on the right and left must be cut out in the range of the fender holder - see picture and drilling pattern.

Fastening of the holding adapter
front left + right:
behind with the passengers footrest
bracket at the frame. Use allen screws
M8 x 30 with washers Ø8,4.
Original screws are obsolete.

1

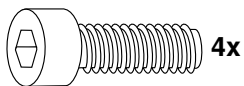
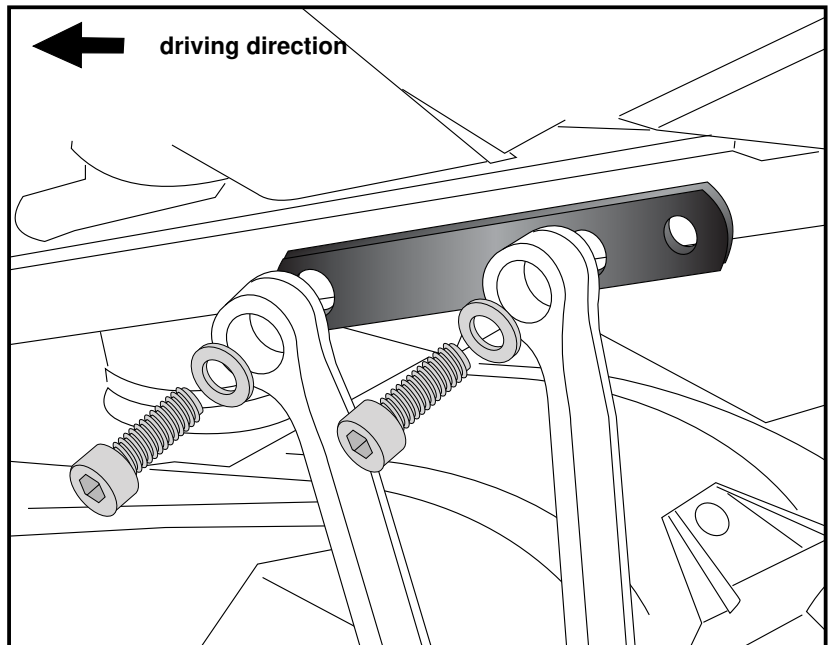

Fastening of the C-Bow Adapter
front left + right:
at the free borings of the holding adapter.
Use allen screws M8 x 30 with washers
Ø8,4.

2

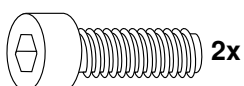
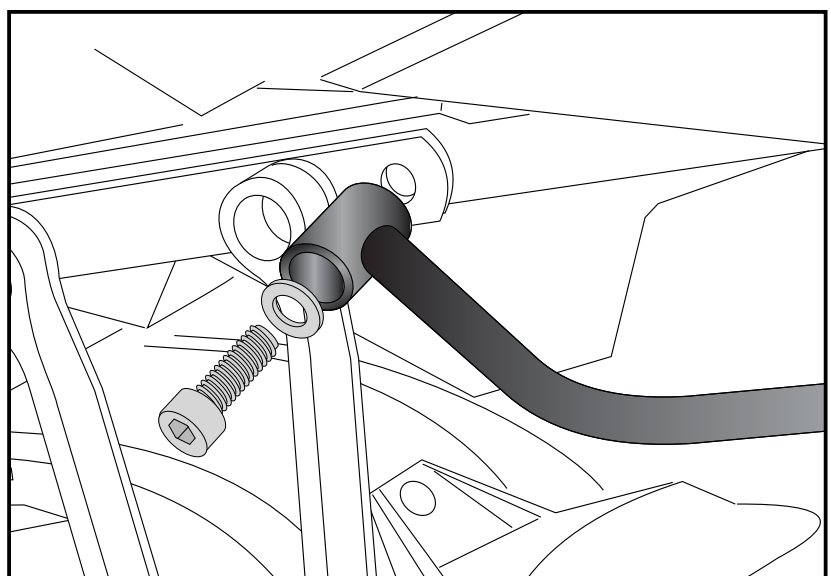



C-Bow

YAMAHA MT - 07

Item.-No.:
630.4537 anthracite

YAMAHA MT - 07

Item.-No.:
4005.048.131 anthracite

Assembling instructions

Fastening of the C-Bow Adapter
rear left + right:

together with the fender holder.

FRONT ①

Use original screws.

REAR ②

Use allen screws M6 x 50. Add alu spacer
ø15 x ø9 x 25mm between adpter and
fender holder.

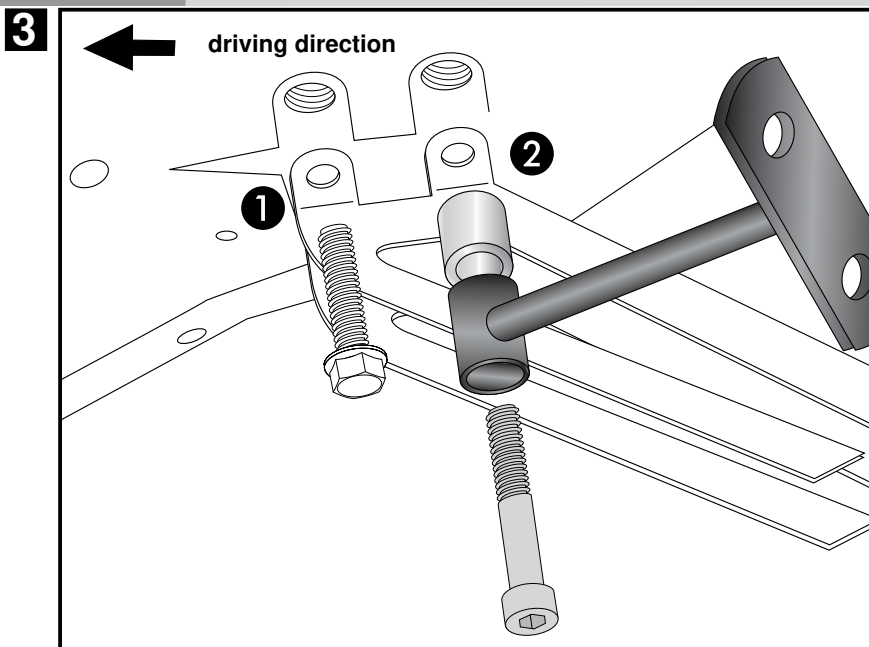
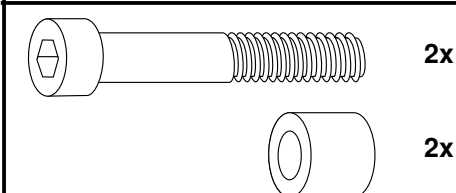

Fastening of the C-Bow:
with hexagon bolts M6 x 18 and
washers ø6,4.

After mounting all parts, the screws
should be tightened to the torque
specified.

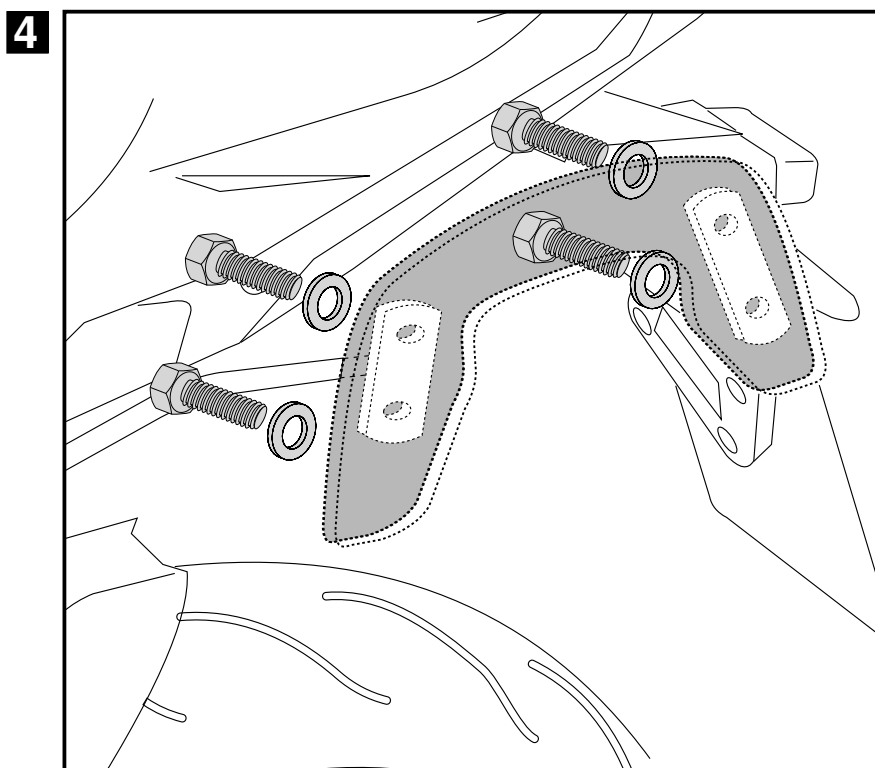



Fahrtrichtung
driving direction



LINKS 1:1
LEFT

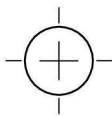

RECHTS 1:1
RIGHT

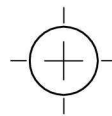

KONTROLLMAßSTAB 1:1

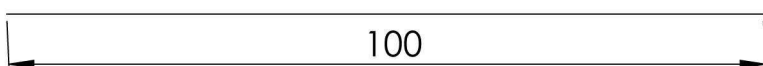

C-BOW: nur hintere Aussparung

C-BOW: only rear cut out