



C-Bow

DUCATI

Hypermotard 796/1100evo/SP

bis Baujahr 2012

Artikel-Nr.: 630.713 schwarz

C-Bow

DUCATI

Hypermotard 796/1100evo/SP

bis Baujahr 2012

Artikel-Nr.:  
4009.002.131 schwarz

## Montage

Der Bausatz umfasst die folgenden Teile:

Stück	Bestellnr.	Bezeichnung	Stück	Bestellnr.	Bezeichnung
2	700007063	C – BOW schwarz	2	150.887	Linsenkopfschraube M8 x 45mm
1	700007571	Halteadapter vorne rechts	8	150.916	Sechskantschraube M6 x 18mm
1	700007572	Halteadapter vorne links	8	150.809	U – Scheibe Ø 6,4
1	700007573	Halteadapter hinten rechts	4	150.810	U – Scheibe Ø 8,4
1	700007574	Halteadapter hinten links	2	150.800	selbstsichernde Mutter M8
2	700007575	Gegenhaltetaschen	1	270.109	Moosgummistreifen 25 cm

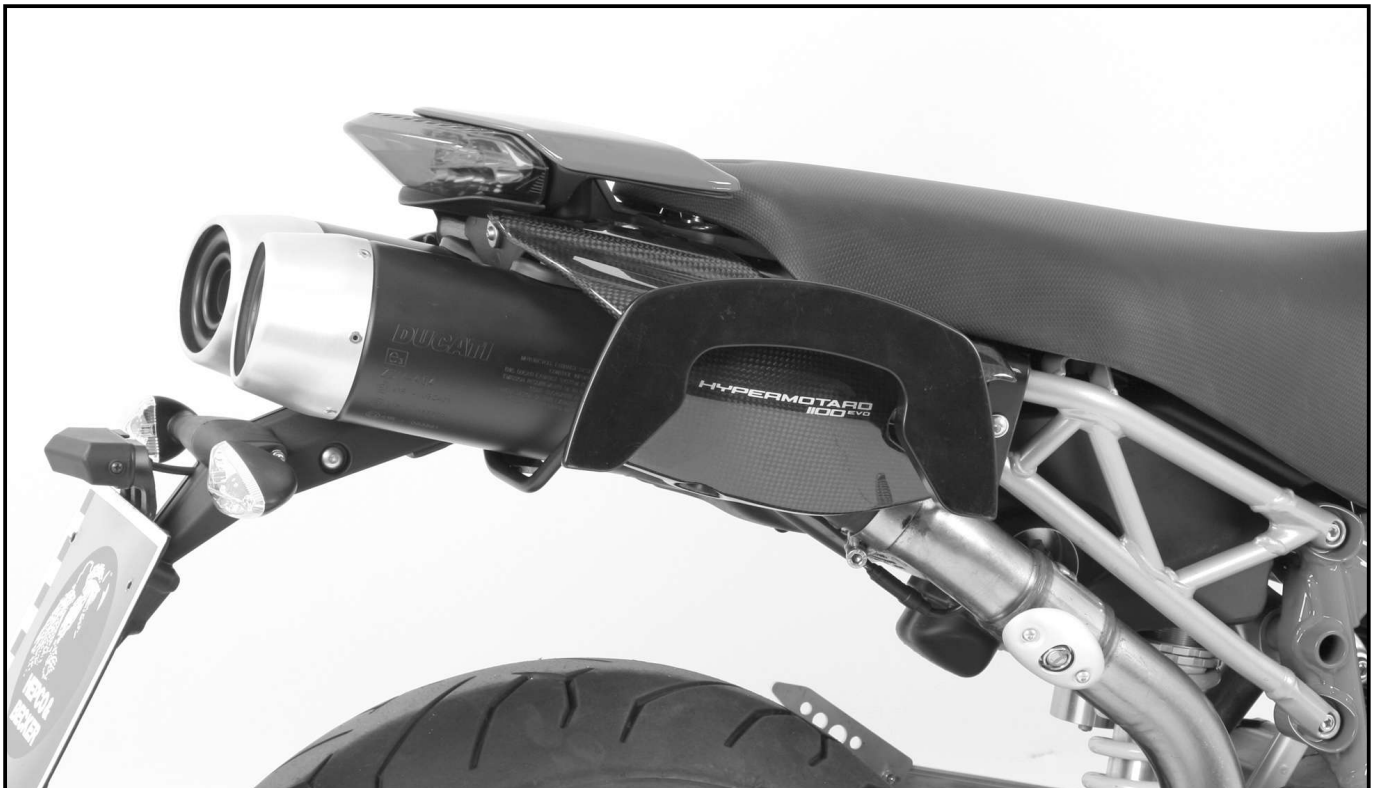

**Anzugsmomente des Motorradherstellers beachten!**  
Nach der Montage alle Verschraubungen auf festen Sitz kontrollieren!  
Bitte beachten Sie unsere beigefügten Serviceinformationen.



**Hepco & Becker GmbH**  
An der Steinmauer 6  
D-66955 Pirmasens  
Tel.: 06331 - 1453 - 100  
Fax: 06331 - 1453 - 120  
eMail: [vertrieb@hepco-becker.de](mailto:vertrieb@hepco-becker.de)  
[www.hepco-becker.de](http://www.hepco-becker.de)



**Krauser GmbH**  
An der Steinmauer 6  
D-66955 Pirmasens  
Tel.: 06331 - 1453 - 250  
Fax: 06331 - 1453 - 260  
eMail: [vertrieb@krauser.de](mailto:vertrieb@krauser.de)  
[www.krauser.de](http://www.krauser.de)



C-Bow

DUCATI

Hypermotard 796/1100evo/SP

bis Baujahr 2012

Artikel-Nr.: 630.713 schwarz

C-Bow

DUCATI

Hypermotard 796/1100evo/SP

bis Baujahr 2012

Artikel-Nr.:  
4009.002.131 schwarz

## Montage

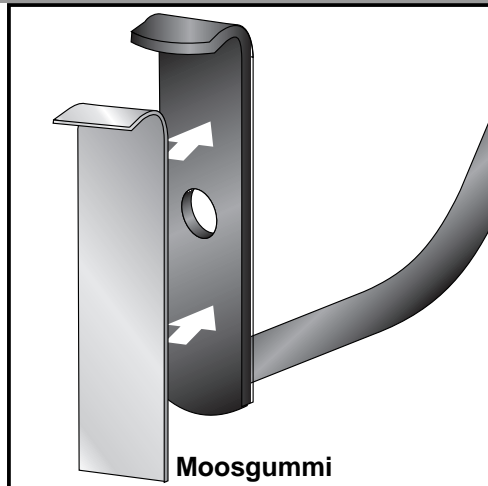

**1**

### Vorbereitung:

- Sitzbank abnehmen
- das beigefügte Moosgummi passend schneiden und auf die Innenseite der beiden Halteadapter vorne links + rechts zum Schutz des Rahmens kleben.

### Montage des vorderen Adapters links und rechts:

am Rahmen geklemmt. Von hinten die Gegenlasche verwenden. Verschraubung mit Linsenkopfschraube M8x45 und U-Scheibe Ø8,4. Von hinten mit selbstsichernder Mutter M8 sowie U-Scheibe Ø8,4 verschrauben. Noch nicht ganz festziehen! Endgültige Position ergibt sich nach Schritt 4.

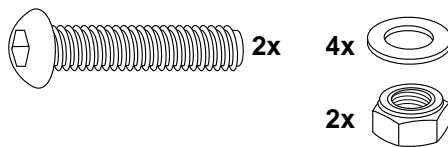

**2**

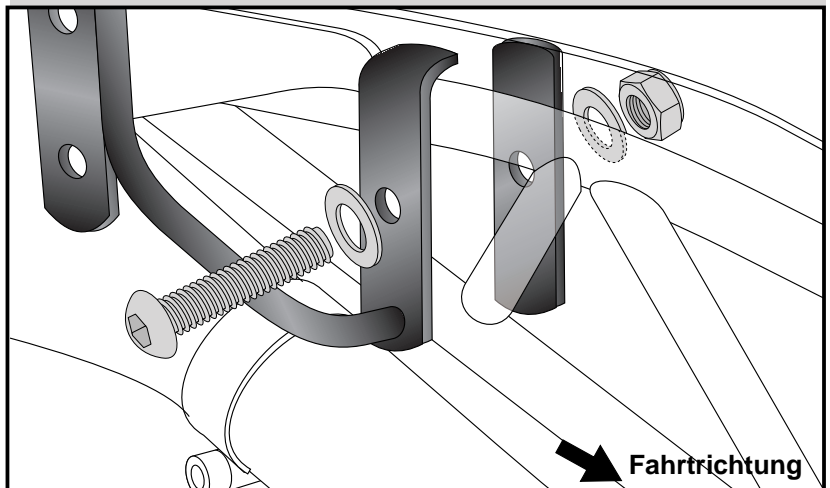

### Montage des hinteren Adapters links und rechts:

Die Montage ist einfacher, wenn man die Halteadapter zuerst mit den Wings verschraubt. Hierzu die Sechskant - Schrauben M6x18 sowie U-Scheiben Ø6,4 verwenden - (noch nicht ganz festziehen). Dann als ganzes am Motorrad montieren.



**3**

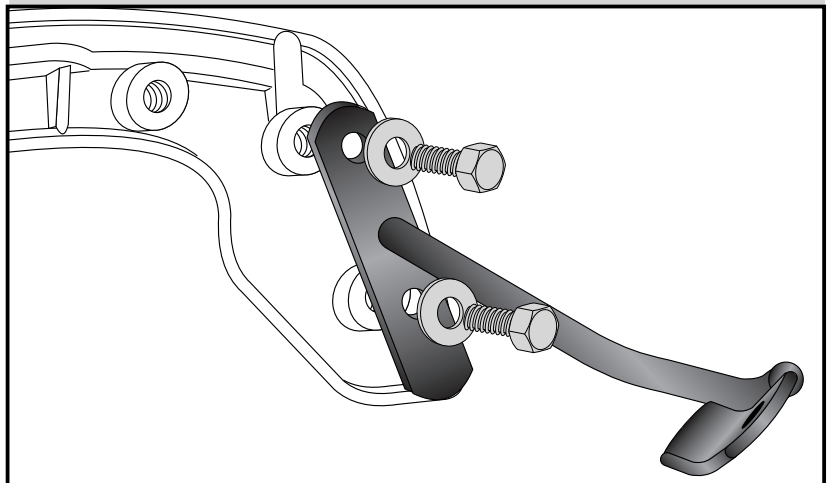



C-Bow

DUCATI

Hypermotard 796/1100evo/SP

bis Baujahr 2012

Artikel-Nr.: 630.713 schwarz

C-Bow

DUCATI

Hypermotard 796/1100evo/SP

bis Baujahr 2012

Artikel-Nr.:  
4009.002.131 schwarz

## Montage

Montage des hinteren Adapters  
links und rechts:

Unterhalb des Auspufftopfes an der  
hinteren Verschraubung, mit der  
Originalschraube.

4

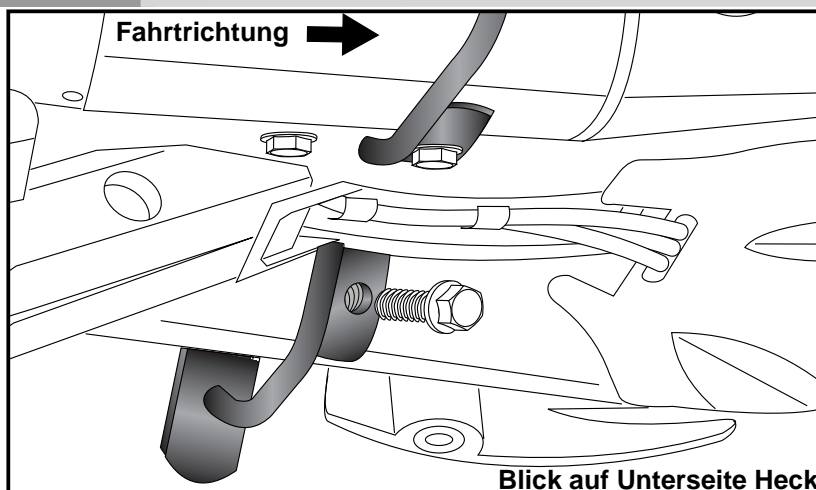

Montage der C-Bow an die vorderen  
Adapter links + rechts:

Dazu die Sechskantschrauben M6x18  
und die U-Scheiben Ø6,4 verwenden.

Teile ausrichten (insbesondere die  
vorderen Adapter) und alle Schrauben  
anziehen.

5

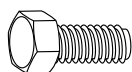
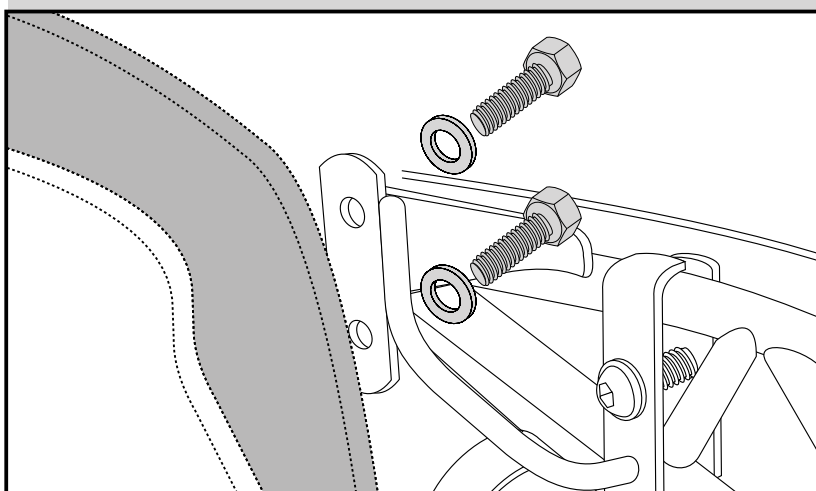

4x

4x





C-Bow

DUCATI

Hypermotard 796/1100evo/SP  
up to date of manufacture 2012

Item.-no.: 630.713 black

C-Bow

DUCATI

Hypermotard 796/1100evo/SP  
up to date of manufacture 2012

Item.-no.: 4009.002.131 black

## Assembling instructions

The kit includes the following parts:

Quant	item no.	description
2	700007063	C – BOW black
1	700007571	adapter front right
1	700007572	adapter front left
1	700007573	adapter rear right
1	700007574	adapter rear left
2	700007575	shackle

Quant	item no.	description
2	150.887	filister head screw M8 x 45mm
8	150.916	hexagon bolt M6 x 18mm
8	150.809	washer Ø 6,4
4	150.810	washer Ø 8,4
2	150.800	self lock nut M8
1	270.109	foam rubber 25 cm

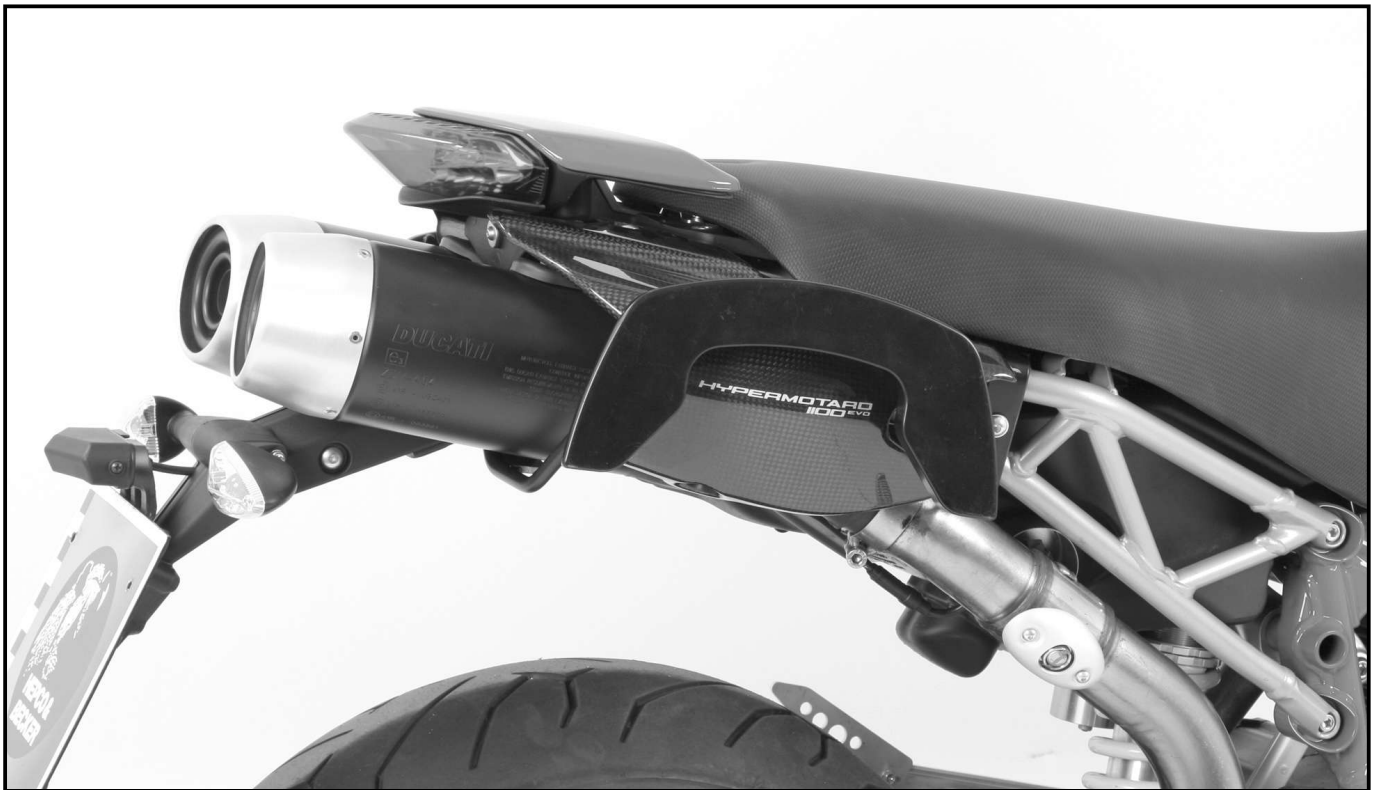

Control all screw connections after the assembling for tightness!  
Please notice our enclosed service information.



**Hepco & Becker GmbH**  
An der Steinmauer 6  
D-66955 Pirmasens  
Tel.: +49 6331 - 1453 - 100  
Fax: +49 6331 - 1453 - 120  
eMail: [vertrieb@hepco-becker.de](mailto:vertrieb@hepco-becker.de)  
[www.hepco-becker.de](http://www.hepco-becker.de)



**Krauser GmbH**  
An der Steinmauer 6  
D-66955 Pirmasens  
Tel.: +49 6331 - 1453 - 250  
Fax: +49 6331 - 1453 - 260  
eMail: [vertrieb@krauser.de](mailto:vertrieb@krauser.de)  
[www.krauser.de](http://www.krauser.de)



C-Bow

DUCATI

Hypermotard 796/1100evo/SP  
up to date of manufacture 2012

Item.-no.: 630.713 black

C-Bow

DUCATI

Hypermotard 796/1100evo/SP  
up to date of manufacture 2012

Item.-no.: 4009.002.131 black

**Assembling instructions**

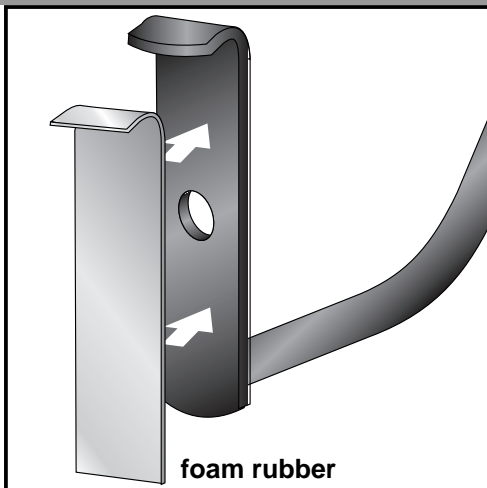

**1**

Preparing:

- Dismantle seat
- cut the foam rubber and stick it at the inner side of the front adapters left + right to protect the frame tube.

Fastening of the front adapters

left+right:

clamped at the frame tubes.  
Use shackle from the rear side.  
Connect front adapters and shackles with filister head screws M8x45, washers Ø8,4 and self lock nuts M8.  
Do not tighten the screw yet!  
Correct position of the adapters is clear after step 4.

**2**

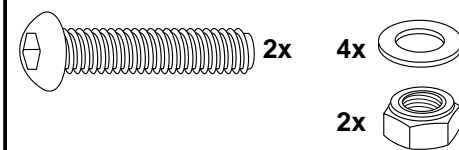
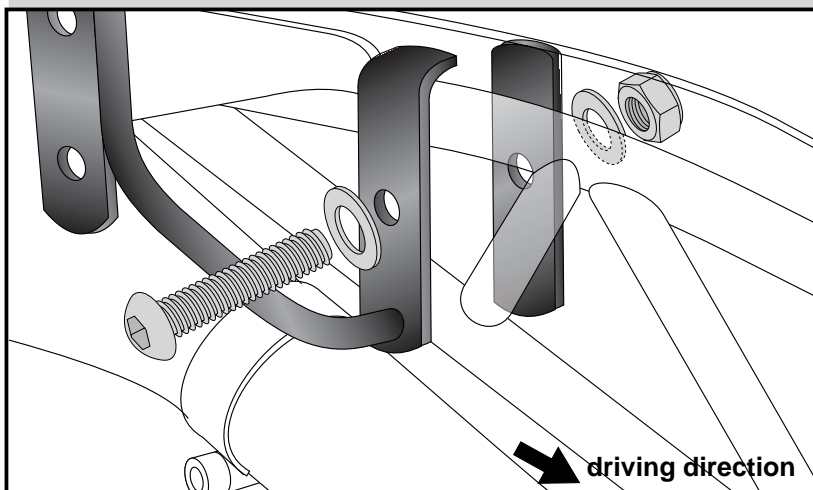

Fastening of the rear adapters

left+right:

first fix the C-Bows to the rear adapters.  
Use hexagon bolts M6 x 18 with washer ø6,4.

**3**

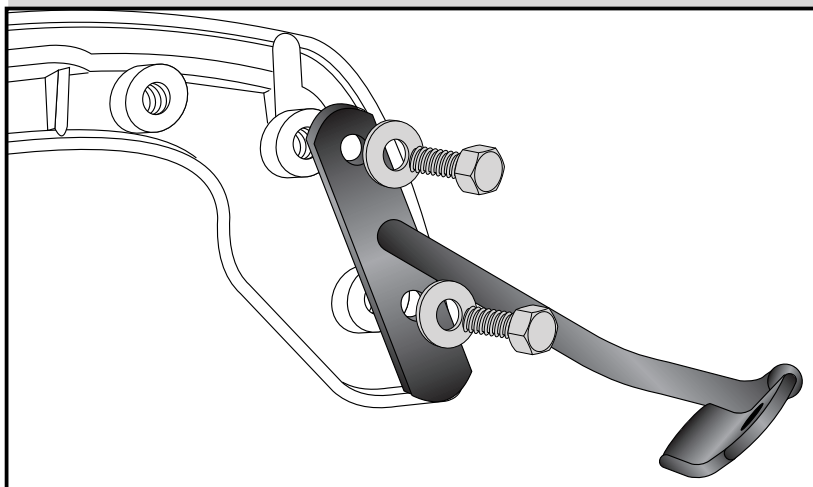



C-Bow

DUCATI

Hypermotard 796/1100evo/SP  
up to date of manufacture 2012

Item.-no.: 630.713 black

C-Bow

DUCATI

Hypermotard 796/1100evo/SP  
up to date of manufacture 2012

Item.-no.: 4009.002.131 black

## Assembling instructions

### Fastening of the rear adapters left+right:

fix the (in step 3 prepared) rear adapters with the C-Bows to the fixing points under the exhaust muffler at the rear, original bolting with original screws.

4

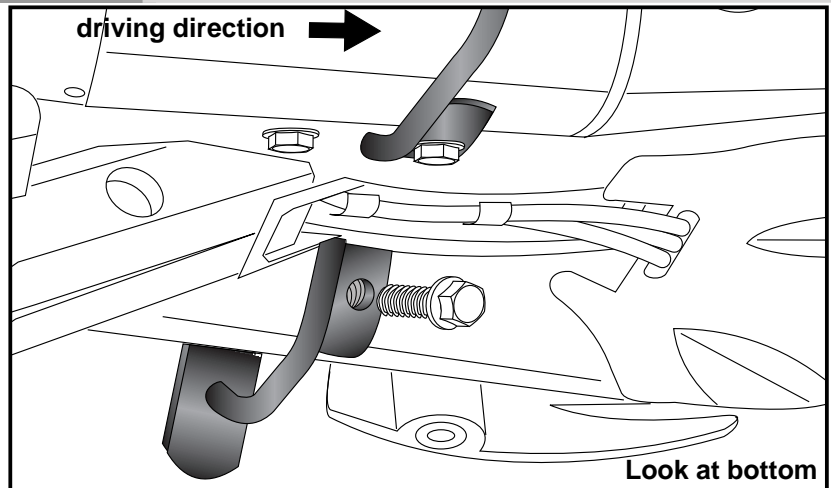

### Fastening of the C-Bow front: Fix the C-Bow to the adapters.

For fastening, use hexagon bolts  
M6 x 18 with washer  $\varnothing 6,4$ .

Align the adapters.  
Now screw on all bolts and nuts.

5

