



C-Bow

DUCATI
Diavel

Artikel-Nr.:
630.7503 schwarz

C-Bow

DUCATI
Diavel

Artikel-Nr.:
4009.005.131 schwarz

Montage

Der Bausatz umfaßt die folgenden Teile:

Stück	Bestellnr.	Bezeichnung
2	700007063	C – BOW schwarz
1	700007700	C – BOW Adapter rechts
1	700007701	C – BOW Adapter links
1	700007702	Halteadapter rechts
1	700007703	Halteadapter links
6	150.763	Inbusschraube M6 x 20mm

Stück	Bestellnr.	Bezeichnung
4	151.003	Senkkopfschraube M8 x 20mm
4	151.068	Senkkopfschraube M8 x 25mm
4	151.302	Senkscheibe Ø 8,4
6	150.809	U – Scheibe Ø 6,4
2	150.995	U – Scheibe Ø 8,4 x 3 mm

Zur Montage Schraubensicherungsmittel verwenden .



Anzugsmomente des Motorradherstellers beachten!
Nach der Montage alle Verschraubungen auf festen Sitz kontrollieren!
Bitte beachten Sie unsere beigefügten Serviceinformationen.



Hepco & Becker GmbH
An der Steinmauer 6
D-66955 Pirmasens
Tel.: 06331 - 1453 - 100
Fax: 06331 - 1453 - 120
eMail: vertrieb@hepco-becker.de
www.hepco-becker.de



Krauser GmbH
An der Steinmauer 6
D-66955 Pirmasens
Tel.: 06331 - 1453 - 250
Fax: 06331 - 1453 - 260
eMail: vertrieb@krauser.de
www.krauser.de

C-Bow

DUCATI
Diavel

Artikel-Nr.:
4009.005.131 schwarz



C-Bow

DUCATI
Diavel

Artikel-Nr.:
630.7503 schwarz

Montage

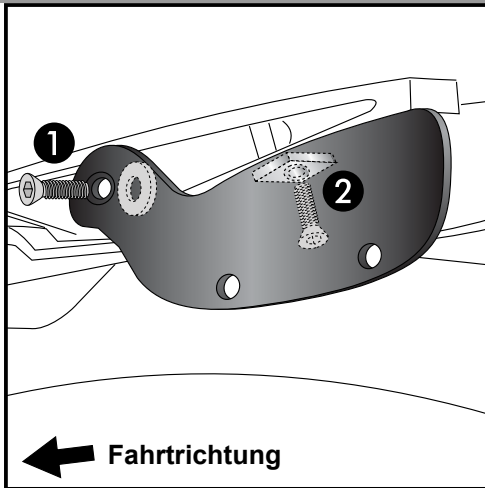

1

Vorbereitung:

Die Sitzbank abnehmen und die Blinker demontieren, damit die Gewindebohrungen im Rahmen zugänglich sind.

Montage der Halteadapter links und rechts:

Die Halteadapter werden mit den Senkschrauben M8 x 20mm am Rahmen montiert. Am vorderen Befestigungspunkt (1) die U – Scheibe Ø8,4 x 3mm zwischenfügen. Dann können die Blinker wieder montiert werden.

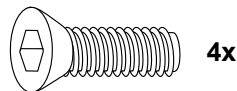

4x

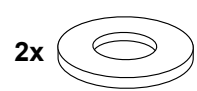

2x

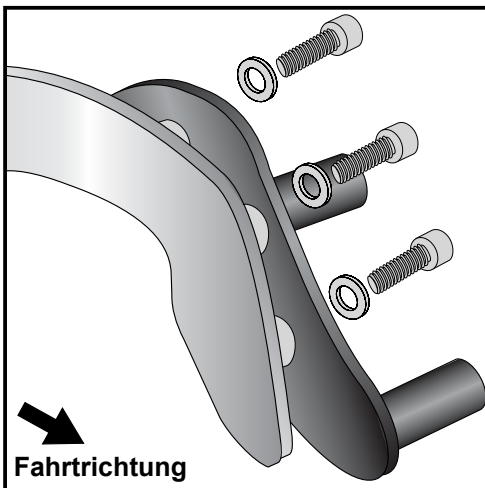

2

Montage der C-Bows an die C-Bow Adapter links und rechts :

Die C-Bows werden jeweils mit drei Inbusschrauben M6 x 20mm und U-Scheiben Ø6,4 an den C-Bow Adaptern montiert.

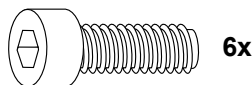

6x



6x

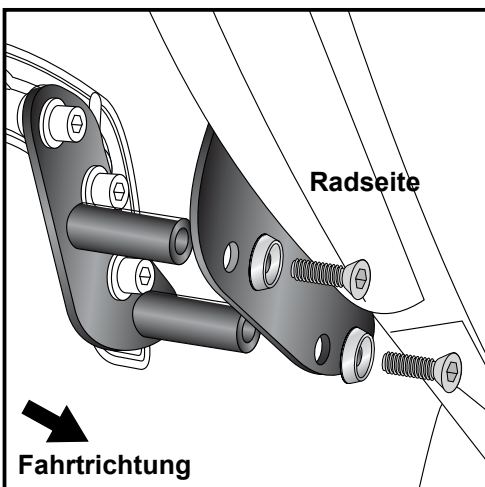

3

Montage der C-Bow Adapter an die Halteadapter links und rechts:

Die so vorbereiteten C-Bows werden mit den Senkschrauben M8 x 25mm und Senkscheiben Ø8,4 an den Halteadaptern montiert.

Wenn C-Bow und Alurack in Kombination montiert werden, werden die C-Bow's auf die Rohradapter des Alurack's montiert.

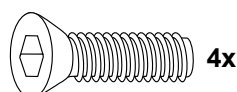

4x



4x



C-Bow

DUCATI
Diavel

Item.-no.: 630.7503 black

C-Bow

DUCATI
Diavel

Item.-no.: 4009.005.131 black

Assembling instructions

The kit includes the following parts:

Quant	item no.	description	Quant	item no.	description
2	700007063	C – BOW black	4	151.003	countersunk head screw M8 x 20mm
1	700007700	C – BOW adapter right	4	151.068	countersunk head screw M8 x 25mm
1	700007701	C – BOW adapter left	4	151.302	countersunk washer Ø 8,4
1	700007702	adapter right	6	150.809	washer Ø 6,4
1	700007703	adapter left	2	150.995	washer Ø 8,4 x 3 mm
6	150.763	allen screw M6 x 20mm			

Use liquid threadlocker to secure all nuts and bolts.



Control all screw connections after the assembling for tightness!
Please notice our enclosed service information.



Hepco & Becker GmbH
An der Steinmauer 6
D-66955 Pirmasens
Tel.: +49 6331 - 1453 - 100
Fax: +49 6331 - 1453 - 120
eMail: vertrieb@hepco-becker.de
www.hepco-becker.de



Krauser GmbH
An der Steinmauer 6
D-66955 Pirmasens
Tel.: +49 6331 - 1453 - 250
Fax: +49 6331 - 1453 - 260
eMail: vertrieb@krauser.de
www.krauser.de



C-Bow

DUCATI
Diavel

Item.-no.: 630.7503 black

C-Bow

DUCATI
Diavel

Item.-no.: 4009.005.131 black

Assembling instructions

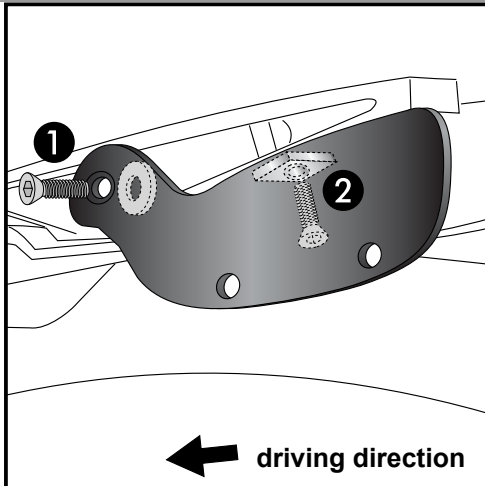

1

Preparing:

Dismantle seat and the rear bliner to reach the threads in the frame.

Fastening of the adapters left+right:

at the frame with countersunk head screws M8 x 20mm.

Front point (1) sandwich washers Ø8,4 x 3mm.

Mount the blinker again.

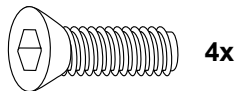

4x

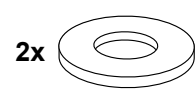

2x

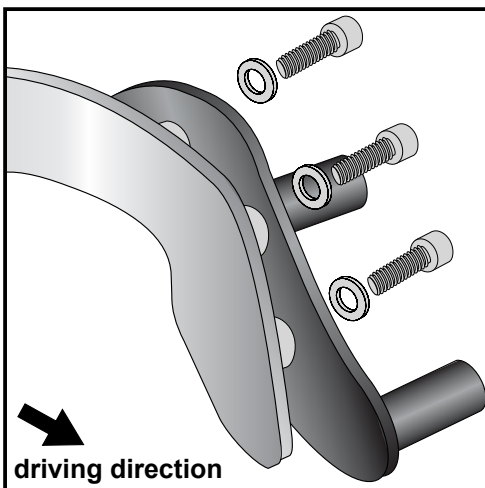

2

Fastening of the C-Bows to the C-Bow adapters left+right:

with allen screws M6x20 and washers Ø6,4.

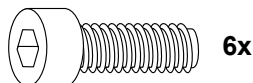

6x



6x

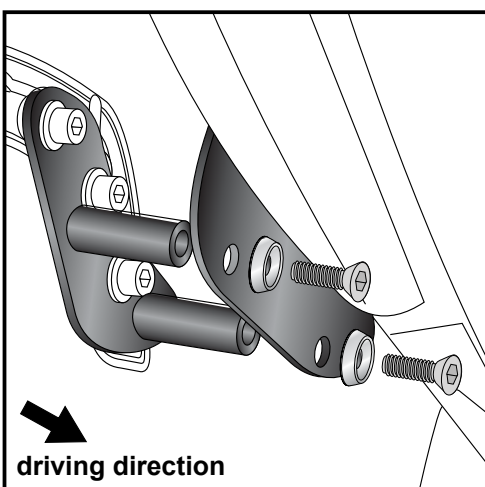

3

Fastening of the C-Bow adapters to the adapters left+right:

with countersunk head screws M8 x 25mm and countersunk washers Ø8,4.

If C-Bow and Alurack are combined, the alurack adapters will be mounted first.

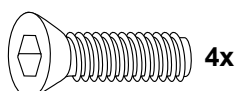

4x



4x